

Plug-in Signal Conditioners MX-UNIT

SELF-SYNCH TRANSMITTER

(front configurable)

Functions & Features

- Converts position signals from a self-synchronizing motor into a DC signal proportional to the rotating shaft position
- Linearization
- 0 % and 100 % input range can be easily selected with the front keys
- Field selectable output range
- Loop test output
- Isolation up to 2000 V AC
- High-density mounting

Typical Applications

- Position indicator using self-synch
- Tank gauge
- Sounding level meter

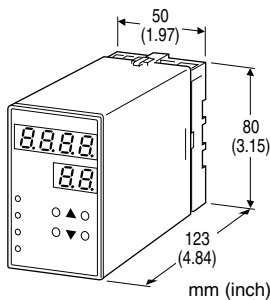

MODEL: MXS-1[1]-[2][3]

ORDERING INFORMATION

- Code number: MXS-1[1]-[2][3]
- Specify a code from below for each [1] through [3].
(e.g. MXS-1V1-K/Q)
- Specify the specification for option code /Q
(e.g. /SET)

INPUT

1: Self-synch signal

[1] OUTPUT

Current

Z1: Range 0 - 20 mA DC (Load resistance 600Ω max.)

Voltage

V1: Range -1 - +1 V DC (Load resistance 1000Ω min.)

V2: Range -10 - +10 V DC (Load resistance 10kΩ min.)

[2] POWER INPUT

AC Power

K: 85 - 132 V AC

(Operational voltage range 85 - 132 V, 47 - 66 Hz)

L: 170 - 264 V AC

(Operational voltage range 170 - 264 V, 47 - 66 Hz)

[3] OPTIONS

blank: none

/Q: With options (specify the specification)

SPECIFICATIONS OF OPTION: Q

EX-FACTORY SETTING

/SET: Preset according to the Ordering Information Sheet
(No. ESU-1739)

GENERAL SPECIFICATIONS

Construction: Plug-in

Connection: M3.5 screw terminals

Housing material: Flame-resistant resin (black)

Isolation: Input to output to power

Linearization: Max. 32 points

■ DISPLAY

LED: 8 mm (.31") 7 segment, red

Number of display digits: 4 digits for DATA display; 2 digits for ITEM display

PV indication: Input signal in engineering unit

Overrange indication: LEDs blinking

Power saving mode: Displays turn off if the keys are untouched for a preset time period

LEDs: Red; the PL1 turns on with negative polarity and the PL2 with programming error.

Programming: Via front keys

• Angle offset

• Linearization

• Zero/span adjustments

• Moving average

• etc...

(Refer to the instruction manual for detailed information)

INPUT SPECIFICATIONS

Measurement range: 0 - 360°

Minimum span: 60°

Input resistance: 1 MΩ min.

Rated input voltage: 90 V AC

Default setting: 0 - 270°



OUTPUT SPECIFICATIONS

• DC Current: 0.0 – 20.0 mA DC

Operational range: 0.0 – 24.0 mA DC

Minimum increment: 0.1 mA

Default setting: 4.0 – 20.0 mA DC

• DC Voltage

Code V1: -1.00 – +1.00 V DC

Operational range: -1.15 – +1.15 V DC

Minimum increment: 10 mV

Code V2: -10.0 – +10.0 V DC

Operational range: -11.5 – +11.5 V DC

Minimum increment: 100 mV

Note: Set to the 100 % output with a larger value than the 0 % output value.

Default setting:

Code V1: -1.00 – +1.00 V DC

Code V2: -10.0 – +10.0 V DC

INSTALLATION

Power Consumption

•AC: Approx. 6 VA

Operating temperature: -5 to +55°C (23 to 131°F)

Operating humidity: 30 to 90 %RH (non-condensing)

Mounting: Surface or DIN rail

Weight: 450 g (0.99 lbs)

PERFORMANCE in percentage of span

Accuracy: $\pm 0.1\%$ or $\pm 0.3^\circ$, whichever is greater.

Required conditions to ensure the accuracy: Input span angle $\geq 60^\circ$; Output $\geq 20\%$ of selectable range

Display accuracy: Accuracy ± 1 digit

Temp. coefficient: $\pm 0.015\%/^\circ\text{C}$ ($\pm 0.008\%/^\circ\text{F}$) of max. span

Response time: ≤ 1 sec. (0 – 90 %) with no moving average setting

Line voltage effect: $\pm 0.1\%$ over voltage range

Insulation resistance: $\geq 100\text{ M}\Omega$ with 500 V DC

Dielectric strength: 2000 V AC @1 minute (input to output to power to ground)

EXTERNAL VIEW

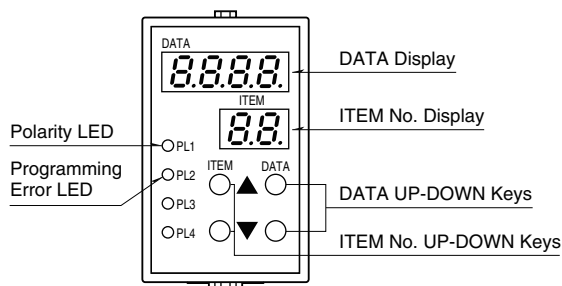

Refer to the instruction manual for detailed procedures.



EXTERNAL DIMENSIONS & TERMINAL ASSIGNMENTS unit: mm (inch)

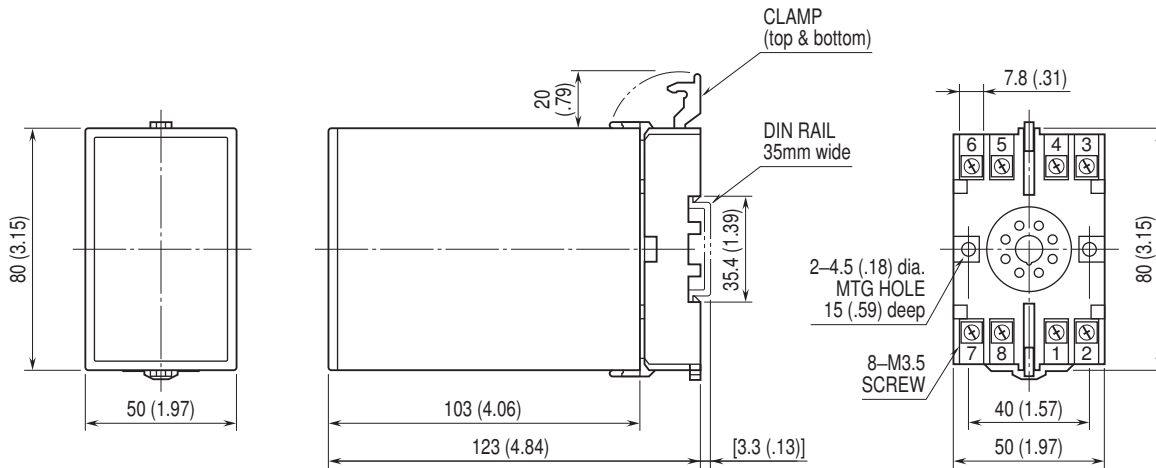

• When mounting, no extra space is needed between units.

SCHEMATIC CIRCUITRY & CONNECTION DIAGRAM

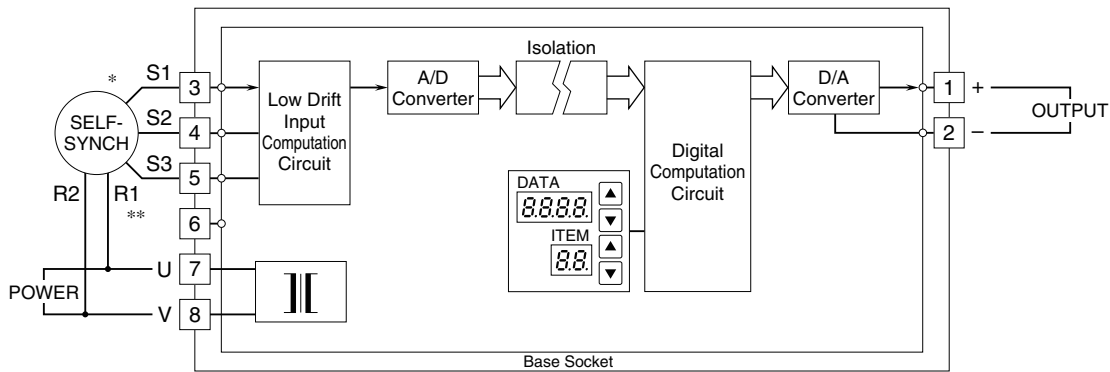

* The output increases when the self-synch rotates clockwise. For changing the operation to counterclockwise, replace the connection of the S2 and S3.

**Be sure that the polarity of the power input to the signal conditioner matches to the self-synch input polarity. When the connection is reversed, the signal conditioner output will be shifted by 180°.



Specifications are subject to change without notice.