

Plug-in Signal Conditioners MX-UNIT

RTD TRANSMITTER

(front configurable)

Functions & Features

- Converts an RTD input into a linearized process signal
- Field-programmable RTD type, temperature and output range
- Easy programming via front UP-DOWN keys with a help of 4-digit and 2-digit displays
- I/O signal inversion feature
- Isolation up to 2000 V AC
- Loop test output
- High-density mounting

Typical Applications

- Isolation between control room and field instrumentation
- Ideal for quick spare part

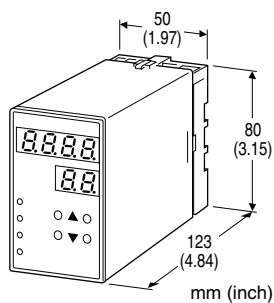

MODEL: MXR-[1]-[2][3]

ORDERING INFORMATION

- Code number: MXR-[1]-[2][3]
Specify a code from below for each [1] through [3].
(e.g. MXR-V1-M2/Q)
- Specify the specification for option code /Q
(e.g. /SET)

[1] OUTPUT

Current

Z1: Range 0 - 20 mA DC (Load resistance 600Ω max.)

Voltage

V1: Range -1 - +1 V DC (Load resistance 1000Ω min.)

V2: Range -10 - +10 V DC (Load resistance 10kΩ min.)

[2] POWER INPUT

AC Power

M2: 100 - 240 V AC (Operational voltage range 85 - 264 V,

47 - 66 Hz)

DC Power

R: 24 V DC

(Operational voltage range 24 V ±10 %, ripple 10 %p-p max.)

P: 110 V DC

(Operational voltage range 85 - 150 V, ripple 10 %p-p max.)

[3] OPTIONS

blank: none

/Q: With options (specify the specification)

SPECIFICATIONS OF OPTION: Q

EX-FACTORY SETTING

/SET: Preset according to the Ordering Information Sheet
(No. ESU-1714)

GENERAL SPECIFICATIONS

Construction: Plug-in

Connection: M3.5 screw terminals

Housing material: Flame-resistant resin (black)

Isolation: Input to output to power

■ DISPLAY

LED: 8 mm (.31") 7 segment, red

Number of display digits: 4 digits for DATA display; 2 digits for ITEM display

PV indication: Input signal in engineering unit

Overrange indication: LEDs blinking

Burnout indication: LEDs blinking and the PLC turns on.

Power saving mode: Displays turn off if the keys are untouched for a preset time period

LEDs: Red; the PL1 turns on with negative polarity and the PL2 with programming error.

Programming: Via front keys

- Input Type
- Moving average
- Burnout
- etc.

For detailed information, refer to the instruction manual.

INPUT SPECIFICATIONS

Maximum leadwire resistance: 200 Ω per wire (3-wire)

Sensing current: ≤ 0.5 mA

Default setting: Pt 100 (JIS '97, IEC) 0 - 100°C



Temperature range

RTD	USABLE RANGE	
	°C	°F
JPt 100 (JIS '89)	-230 to +560	-382 to +1040
Pt 100 (JIS '89)	-230 to +900	-382 to +1652
Pt 100 (JIS '97/IEC)	-230 to +900	-382 to +1652
Pt 50Ω (JIS '81)	-230 to +700	-382 to +1292
Ni 508.4Ω	-100 to +330	-148 to +626
Pt 1000	-230 to +900	-382 to +1652
Ni 100	-100 to +250	-148 to +482
Cu 10Ω @25°C	-210 to +310	-346 to +590

Note 1: Set the upper range temperature with a larger value than the lower range temperature value.

Note 2: Inverted output is available with the configuration.

Note 3: Operational range is of -15 to +115% or in the usable range as indicated above.

OUTPUT SPECIFICATIONS

• **DC Current:** 0.0 - 20.0 mA DC

Operational range: 0.0 - 24.0 mA DC

Minimum increment: 0.1 mA

Default setting: 4.0 - 20.0 mA DC

• **DC Voltage**

Code V1: -1.00 - +1.00 V DC

Operational range: -1.15 - +1.15 V DC

Minimum increment: 10 mV

Code V2: -10.0 - +10.0 V DC

Operational range: -11.5 - +11.5 V DC

Minimum increment: 100 mV

Note: Set to the 100 % output with a larger value than the 0 % output value.

Default setting:

Code V1: -1.00 - +1.00 V DC

Code V2: -10.0 - +10.0 V DC

INSTALLATION

Power Consumption

• **AC:** Approx. 6 VA

• **DC:** Approx. 3.5 W (100 mA at 24 V)

Operating temperature: -5 to +55°C (23 to 131°F)

Operating humidity: 30 to 90 %RH (non-condensing)

Mounting: Surface or DIN rail

Weight: 450 g (0.99 lbs)

PERFORMANCE

Accuracy: Input + output

Input: ±0.3°C (±0.54°F) typical

±0.5°C (±0.9°F) for Cu 10

Output: ±0.05 %

Min. span required to ensure the accuracy:

20% of the nominal I/O range

Display accuracy: Input accuracy ±1 digit

Temp. coefficient: ±0.015 %/°C (±0.008 %/°F)

Response time: ≤ 0.5 sec. (0 - 90 %)

Burnout response time: ≤ 2 sec.

Line voltage effect: ±0.1 % over voltage range

Insulation resistance: ≥ 100 MΩ with 500 V DC

Dielectric strength: 2000 V AC @1 minute (input to output to power to ground)

STANDARDS & APPROVALS

CE conformity:

EMC Directive (2004/108/EC)

EMI EN 61000-6-4: 2007

EMS EN 61000-6-2: 2005

Low Voltage Directive (2006/95/EC)

EN 61010-1: 2001

Installation Category II

Pollution Degree 2

Input or output to power: Reinforced insulation (300 V)

Input to output: Basic insulation (300 V)



EXTERNAL VIEW

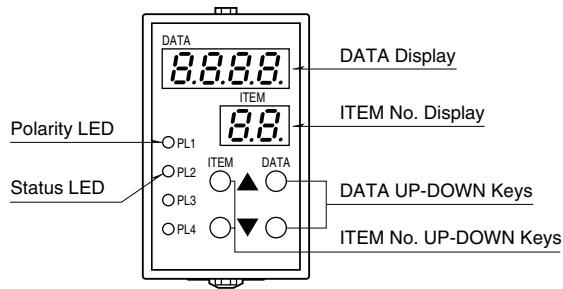

Refer to the instruction manual for detailed procedures.

EXTERNAL DIMENSIONS & TERMINAL ASSIGNMENTS unit: mm (inch)

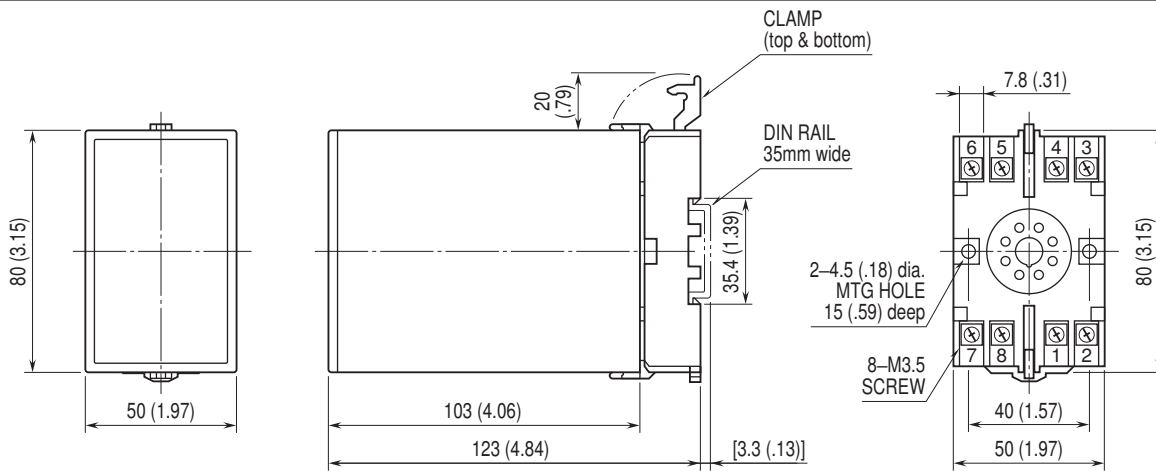

• When mounting, no extra space is needed between units.

SCHEMATIC CIRCUITRY & CONNECTION DIAGRAM

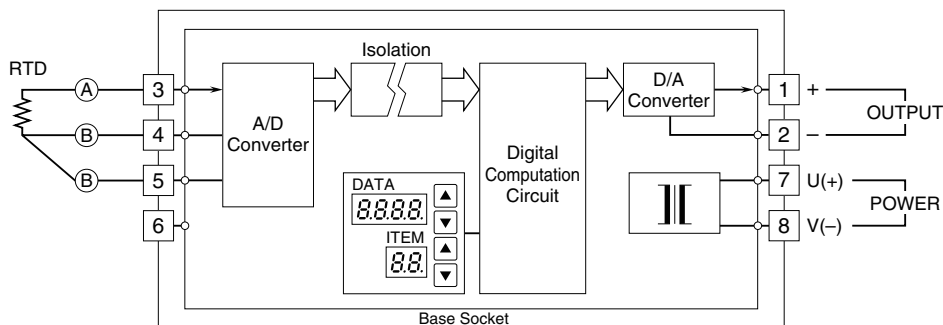

Specifications are subject to change without notice.