

Plug-in Signal Conditioners MX-UNIT

PROGRAMMED RAMP GENERATOR

(front configurable)

Functions & Features

- Generates various patterns of output by front UP-DOWN key programming
- Upscale/downscale limits, output cycle can be programmed
- Programming and display in engineering units
- Max. 16-point-segment ramps can be generated
- Loop test output

Typical Applications

- Parameters setting for computers and DCS
- Signals used in a panel, which are rarely changed

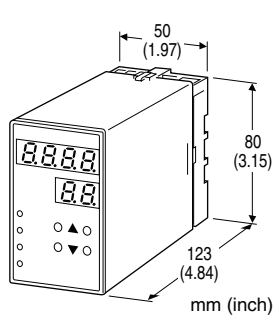

MODEL: MXMS-[1]-[2][3]

ORDERING INFORMATION

- Code number: MXMS-[1]-[2][3]
Specify a code from below for each [1] through [3].
(e.g. MXMS-V1-M2/Q)
- Specify the specification for option code /Q
(e.g. /SET)

[1] OUTPUT

Current

Z1: Range 0 - 20 mA DC (Load resistance 600Ω max.)

Voltage

V1: Range -1 - +1 V DC (Load resistance 1000Ω min.)

V2: Range -10 - +10 V DC (Load resistance 10kΩ min.)

[2] POWER INPUT

AC Power

M2: 100 - 240 V AC (Operational voltage range 85 - 264 V, 47 - 66 Hz)

DC Power

R: 24 V DC

(Operational voltage range 24 V ±10 %, ripple 10 %p-p max.)

P: 110 V DC

(Operational voltage range 85 - 150 V, ripple 10 %p-p max.)

[3] OPTIONS

blank: none

/Q: With options (specify the specification)

SPECIFICATIONS OF OPTION: Q

EX-FACTORY SETTING

/SET: Preset according to the Ordering Information Sheet
(No. ESU-1702)

GENERAL SPECIFICATIONS

Construction: Plug-in

Connection: M3.5 screw terminals

Housing material: Flame-resistant resin (black)

Isolation: Control I/O to output to power

Programming: Via front keys

- Scaled range
- Output range
- Output wave type and cycle
- etc...

(Refer to the instruction manual for details)

■ DISPLAY

LED: 8 mm (.31") 7 segment, red

Number of display digits: 4 digits for DATA display; 2 digits for ITEM display

Scaling: -9999 to 9999

MV indication: Output signal in engineering unit

Overrange indication: LEDs blinking

Power saving mode: Displays turn off if the keys are untouched for a preset time period

LEDs: Red; the PL1 turns on with negative polarity and the PL2 turns on during a program is running.

INPUT SPECIFICATIONS

■ Output Enable Command

Minimum ON time: 0.1 sec. (Prevent chattering.)

Sensing voltage: 5 V DC

ON/OFF levels: ≤ 500 Ω / ≤ 0.65 V for ON;
≥ 30 kΩ / 4.5 V for OFF

OUTPUT SPECIFICATIONS

■ DC Current: 0.0 - 20.0 mA DC

Operational range: 0.0 - 24.0 mA DC

Minimum increment: 0.1 mA

Default setting: 4.0 - 20.0 mA DC

■ DC Voltage

Code V1: -1.00 - +1.00 V DC



Operational range: -1.15 - +1.15 V DC

Minimum increment: 10 mV

Code V2: -10.0 - +10.0 V DC

Operational range: -11.5 - +11.5 V DC

Minimum increment: 100 mV

Note: Set to the 100 % output with a larger value than the 0 % output value.

Default setting:

Code V1: -1.00 - +1.00 V DC

Code V2: -10.0 - +10.0 V DC

■ **RUN OUTPUT (open collector)**

Max. collector-emitter voltage: 30 V

Max. collector current: 30 mA

Saturation voltage: 1.1 V or less

Input to output: Basic insulation (300 V)

INSTALLATION

Power consumption

•AC:

Approx. 3.8 VA at 100 V

Approx. 5.2 VA at 200 V

Approx. 6.1 VA at 264 V

•DC: Approx. 3.5 W (100 mA at 24 V)

Operating temperature: -5 to +55°C (23 to 131°F)

Operating humidity: 30 to 90 %RH (non-condensing)

Mounting: Surface or DIN rail

Weight: 450 g (0.99 lbs)

PERFORMANCE in percentage of max. span

Accuracy: ± 0.05 % (output accuracy)

The output span must be 20 % or greater of the entire range to satisfy the described accuracy.

Display accuracy: Output accuracy ± 1 digit (with 0.0 - 100.0 scaling)

Time axis error: ± 0.5 sec. per minute

Temp. coefficient: ± 0.015 %/°C (± 0.008 %/°F)

Response time: ≤ 0.5 sec. (0 - 90 %)

Line voltage effect: ± 0.1 % over voltage range

Insulation resistance: $\geq 100M\Omega$ with 500 V DC

Dielectric strength: 2000 V AC @ 1 minute
(control I/O to output to power to ground)

STANDARDS & APPROVALS

CE conformity:

EMC Directive (2004/108/EC)

EMI EN 61000-6-4: 2007

EMS EN 61000-6-2: 2005

Low Voltage Directive (2006/95/EC)

EN 61010-1: 2001

Installation Category II

Pollution Degree 2

Input or output to power: Reinforced insulation (300 V)



幸託有限公司
XIN TOP CORPORATION

TEL : (02)2598-1199

FAX : (02)2596-2331

E-mail : info@xintop.com

Website : www.xintop.com

EXTERNAL VIEW

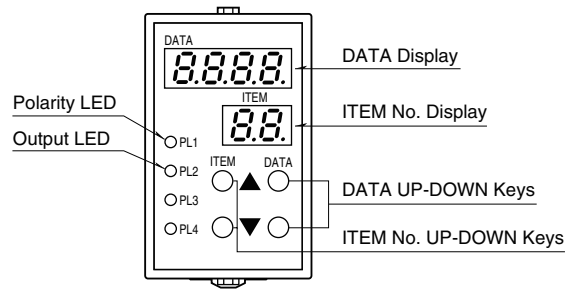

Refer to the instruction manual for detailed procedures.

EXTERNAL DIMENSIONS & TERMINAL ASSIGNMENTS unit: mm (inch)

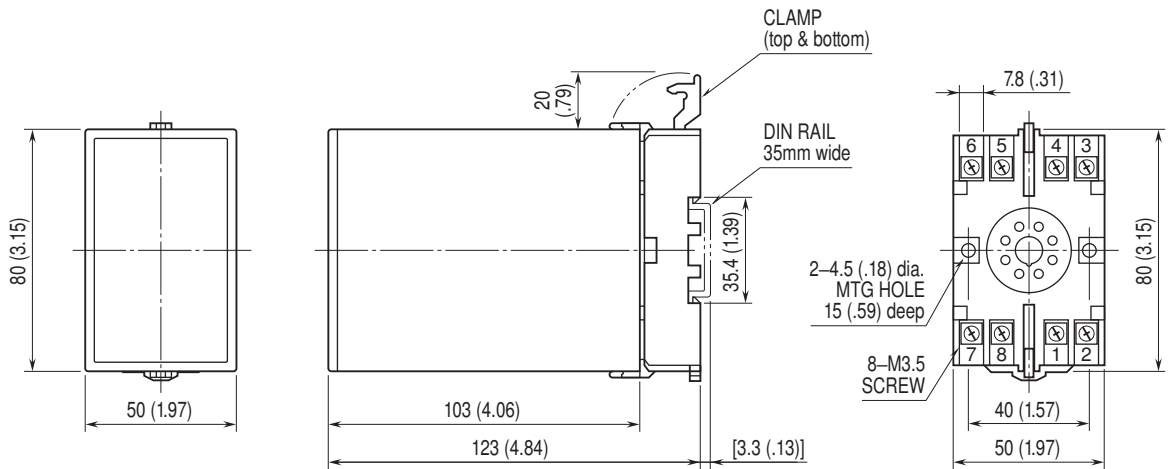

• When mounting, no extra space is needed between units.

SCHEMATIC CIRCUITRY & CONNECTION DIAGRAM

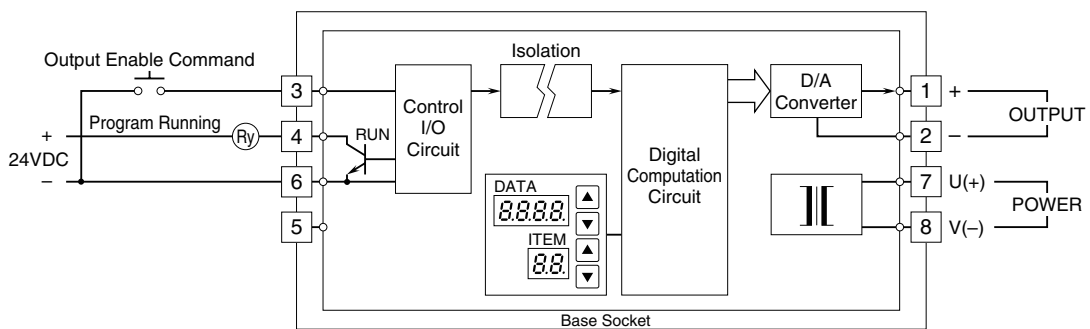

Specifications are subject to change without notice.