

## Plug-in Signal Conditioners MX-UNIT

### STRAIN GAUGE TRANSMITTER

(front configurable)

#### Functions & Features

- Provides a DC output signal proportional to a bridge type strain gauge utilized in load cells and pressure transducers
- Compatibility with strain gauges of various bridge resistances and output ratings
- Supplies required excitation voltage; 0.1 - 12.0 V adjustable
- Wide-range adjustments: 0 - 100 % for zero and gain
- Isolation up to 2000 V AC
- Loop test output
- High-density mounting

#### Typical Applications

- Weighing system for tanks, hoppers and silos
- Weighing system using cranes
- Pressure sensor utilizing strain gauges
- Float level meter utilizing strain gauges

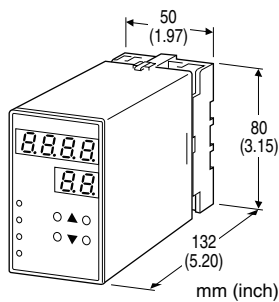

## MODEL: MXLC-[1][2]-[3][4]

### ORDERING INFORMATION

- Code number: MXLC-[1][2]-[3][4]
- Specify a code from below for each [1] through [4]. (e.g. MXLC-S1V1-M2/Q)
- Specify the specification for option code /Q (e.g. /SET)

#### [1] INPUT STRAIN GAUGE

- S1: 0.0 - 3.0 mV/V
- S2: 0.0 - 10.0 mV/V
- S3: 0.0 - 30.0 mV/V

#### [2] OUTPUT

##### Current

Z1: Range 0 - 20 mA DC (Load resistance 600Ω max.)

#### Voltage

V1: Range -1 - +1 V DC (Load resistance 1000Ω min.)

V2: Range -10 - +10 V DC (Load resistance 10kΩ min.)

### [3] POWER INPUT

#### AC Power

M2: 100 - 240 V AC (Operational voltage range 85 - 264 V, 47 - 66 Hz)

#### DC Power

R: 24 V DC

(Operational voltage range 24 V ±10 %, ripple 10 %p-p max.)

P: 110 V DC

(Operational voltage range 85 - 150 V, ripple 10 %p-p max.)

### [4] OPTIONS

blank: none

/Q: With options (specify the specification)

### SPECIFICATIONS OF OPTION: Q

#### EX-FACTORY SETTING

/SET: Preset according to the Ordering Information Sheet (No. ESU-1704)

### GENERAL SPECIFICATIONS

Construction: Plug-in

Connection: M3.5 screw terminals

Housing material: Flame-resistant resin (black)

Isolation: Input to output to power

Overage output: Approx. -15 to +115 %

Excitation adjustment: 0.1 - 12.0 V (front)

Zero adjustment: 0 - 100 % (front)

Gain adjustment: 0 - 9.99 (front)

Tare adjustment: -999.9 - 999.9 % (front or by external contact)

#### ■ DISPLAY

LED: 8 mm (.31") 7 segment, red

Number of display digits: 4 digits for DATA display; 2 digits for ITEM display

Scaling: -9999 to 9999

(decimal point position selectable)

PV indication: Input signal in engineering unit

Overage indication: LEDs blinking

Power saving mode: Displays turn off if the keys are untouched for a preset time period

LEDs: Red lights turn on with negative polarity and with contact input.

Programming: Via front keys

- Scaled range
- Moving average
- etc...



(Refer to the instruction manual for details)

## INPUT SPECIFICATIONS

### ■ STRAIN GAUGE INPUT

#### • Strain Gauge

**Rated output from strain gauge:**

S1: -30.0 – +30.0 mV, span 1.0 – 30.0 mV

S2: -99.9 – +99.9 mV, span 3.0 – 99.9 mV

S3: -300.0 – +300.0 mV, span 10.0 – 300.0 mV

**Default setting:**

S1: 0.0 - 3.0 mV/V

S2: 0.0 - 10.0 mV/V

S3: 0.0 - 30.0 mV/V

Note: Consult factory for use with a compression/tension load cells.

• **Excitation:** 0.1 – 12.0 V adjustable (0.1 V increments)

**Maximum current:** 30 mA

**Default setting:** 1.0 V

■ **CONTACT INPUT:** TTL level (5V-CMOS level), open collector or dry contact (saturation voltage  $\leq 1$  V, sink current 0.5 mA)

## OUTPUT SPECIFICATIONS

• **DC Current:** 0.0 – 20.0 mA DC

**Operational range:** 0.0 – 24.0 mA DC

**Minimum increment:** 0.1 mA

**Default setting:** 4.0 – 20.0 mA DC

• **DC Voltage**

**Code V1:** -1.00 – +1.00 V DC

**Operational range:** -1.15 – +1.15 V DC

**Minimum increment:** 10 mV

**Code V2:** -10.0 – +10.0 V DC

**Operational range:** -11.5 – +11.5 V DC

**Minimum increment:** 100 mV

Note: Set to the 100 % output with a larger value than the 0 % output value.

**Default setting:**

**Code V1:** -1.00 – +1.00 V DC

**Code V2:** -10.0 – +10.0 V DC

## INSTALLATION

**Power Consumption**

• **AC:** Approx. 10 VA

• **DC:** Approx. 7 W (300 mA at 24 V)

**Operating temperature:** -5 to +55°C (23 to 131°F)

**Operating humidity:** 30 to 90 %RH (non-condensing)

**Mounting:** Surface or DIN rail

**Weight:** 450 g (0.99 lbs)

## PERFORMANCE

**Accuracy:** Input + output

**Input:**  $\pm 0.1$  %

**Output:**  $\pm 0.1$  %

**Display accuracy:** Input accuracy  $\pm 1$  digit (with 0.0 – 100.0 scaling)

**Temp. coefficient:**  $\pm 0.015$  %/°C ( $\pm 0.008$  %/°F)

**Response time:** 0.7 – 1.5 sec. (0 – 90 %)

**Excitation:** Set value  $\pm 250$  mV

**Line voltage effect:**  $\pm 0.1$  % over voltage range

**Insulation resistance:**  $\geq 100$  M $\Omega$  with 500 V DC

**Dielectric strength:** 2000 V AC @1 minute (input to output to power to ground)

## STANDARDS & APPROVALS

**CE conformity:**

EMC Directive (2004/108/EC)

EMI EN 61000-6-4: 2007

EMS EN 61000-6-2: 2005

Low Voltage Directive (2006/95/EC)

EN 61010-1: 2001

Installation Category II

Pollution Degree 2

Input to output to power – Basic insulation (300 V)



## EXTERNAL VIEW

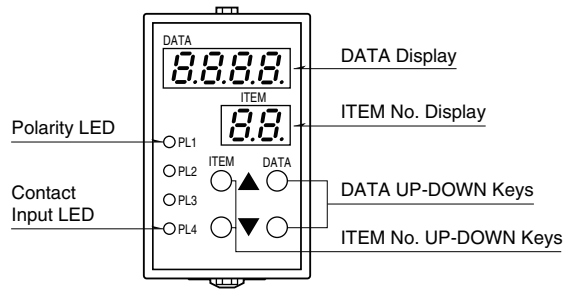

Refer to the instruction manual for detailed procedures.

## EXTERNAL DIMENSIONS & TERMINAL ASSIGNMENTS unit: mm (inch)

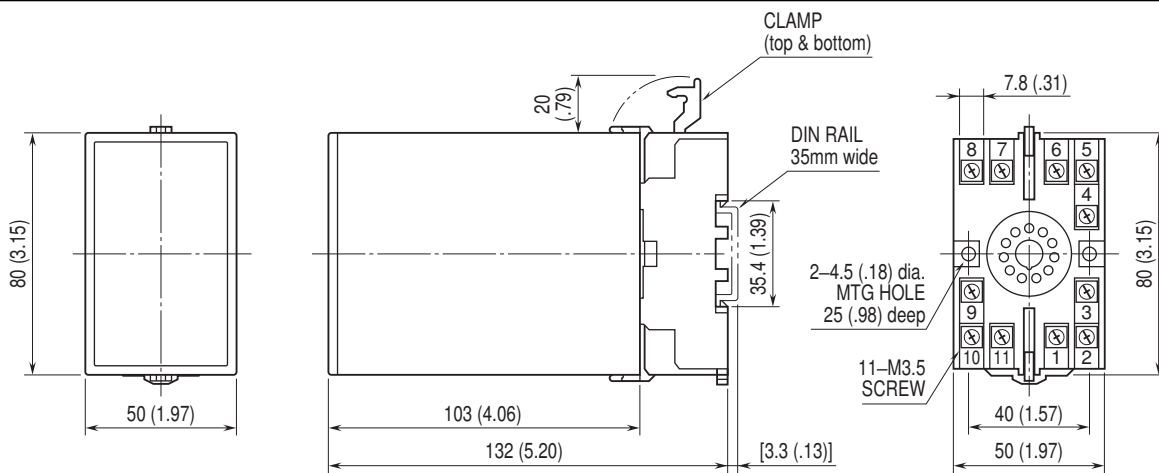

• When mounting, no extra space is needed between units.

## SCHEMATIC CIRCUITRY & CONNECTION DIAGRAM

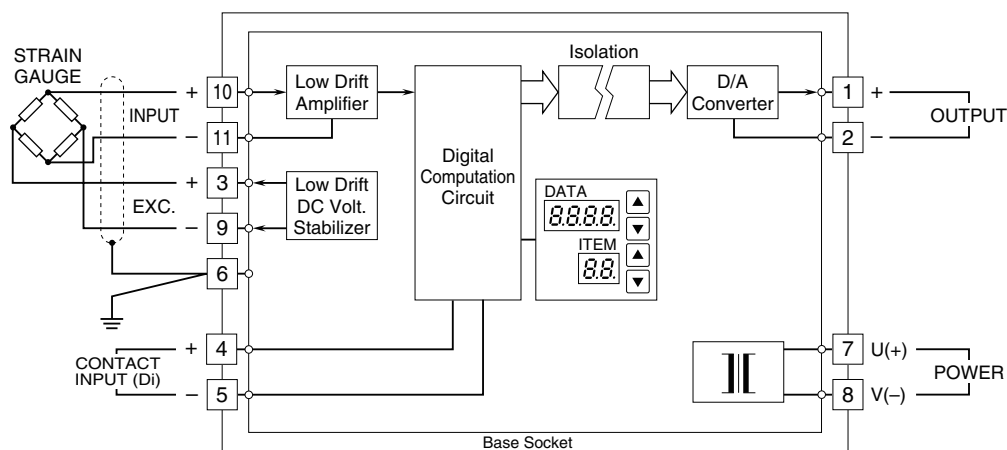

Specifications are subject to change without notice.