

## Plug-in Signal Conditioners MX-UNIT

### COMPUTER BACKUP STATION

(front configurable)

#### Functions & Features

- Manipulates/holds analog signals via contact input from a computer
- Manual control available by the 'Soft-Terminal' indicator/controller (model: ST/STL).
- Restarts at the last stored value before power failure

#### Typical Applications

- Computer and DCS backup applications
- Used as manual controller
- Valve/damper control with ON-OFF signals

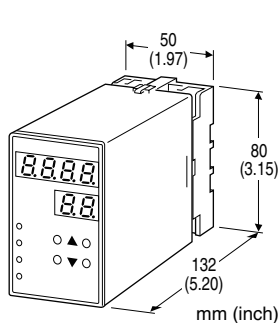

### MODEL: MXCB-[1]-[2][3]

#### ORDERING INFORMATION

- Code number: MXCB-[1]-[2][3]
- Specify a code from below for each [1] through [3]. (e.g. MXCB-V1-M2/Q)
- Specify the specification for option code /Q (e.g. /SET)

#### [1] OUTPUT

##### Current

Z1: Range 0 - 20 mA DC (Load resistance 600Ω max.)

##### Voltage

V1: Range -1 - +1 V DC (Load resistance 1000Ω min.)

V2: Range -10 - +10 V DC (Load resistance 10kΩ min.)

#### [2] POWER INPUT

##### AC Power

M2: 100 - 240 V AC (Operational voltage range 85 - 264 V, 47 - 66 Hz)

##### DC Power

R3: 12 - 24 V DC

(Operational voltage range 10.8 - 26.4 V, ripple 10 %p-p max.)

P: 110 V DC

(Operational voltage range 85 - 150 V, ripple 10 %p-p max.)

#### [3] OPTIONS

blank: none

/Q: With options (specify the specification)

#### SPECIFICATIONS OF OPTION: Q

##### EX-FACTORY SETTING

/SET: Preset according to the Ordering Information Sheet (No. ESU-1745)

#### RELATED PRODUCTS

- Soft-Terminal (model: ST/STL)

#### GENERAL SPECIFICATIONS

Construction: Plug-in

Connection: M3.5 screw terminals

Housing material: Flame-resistant resin (black)

Isolation: Input to output to power

##### ■ DISPLAY

LED: 8 mm (.31") 7 segment, red

Number of display digits: 4 digits for DATA display; 2 digits for ITEM display

Scaling: -9999 to 9999

PV indication: Output signal in engineering unit

Overrange indication: LEDs blinking

Power saving mode: Displays turn off if the keys are untouched for a preset time period

LEDs: Red; the PL1 turns on with negative polarity.

Programming: Via front keys

- Scaled range
- Response time
- Trace back mode
- Initial value, Hi, Lo
- etc.

Refer to the instruction manual for detailed information.

#### INPUT SPECIFICATIONS

■ CONTACT INPUT: TTL level (5V-CMOS level) or open collector/dry contact (saturation voltage  $\leq$  1 V, sink current 0.5 mA)

- UP/DOWN/STOP signals (input from the computer)

UP/DOWN signal: Increases/decreases the analog output.

STOP signal: Switches AUTO/MAN modes.

- UP/DOWN signals (input from the Soft-Terminal):

Controls the analog output in MAN mode.



## OUTPUT SPECIFICATIONS

• **DC Current:** 0.0 – 20.0 mA DC  
**Operational range:** 0.0 – 24.0 mA DC  
**Minimum increment:** 0.1 mA  
**Default setting:** 4.0 – 20.0 mA DC

• **DC Voltage**  
**Code V1:** -1.00 – +1.00 V DC  
**Operational range:** -1.15 – +1.15 V DC  
**Minimum increment:** 10 mV  
**Code V2:** -10.0 – +10.0 V DC  
**Operational range:** -11.5 – +11.5 V DC  
**Minimum increment:** 100 mV

Note: Set to the 100 % output with a larger value than the 0 % output value.

**Default setting:**  
**Code V1:** -1.00 – +1.00 V DC  
**Code V2:** -10.0 – +10.0 V DC

Input to output to power – Basic insulation (300 V)

## INSTALLATION

**Power Consumption**  
• **AC:** Approx. 10 VA  
• **DC:** Approx. 3.5 W (150 mA at 24 V)  
**Operating temperature:** -5 to +55°C (23 to 131°F)  
**Operating humidity:** 30 to 90 %RH (non-condensing)  
**Mounting:** Surface or DIN rail  
**Weight:** 450 g (0.99 lbs)

## PERFORMANCE in percentage of max. span

**Accuracy:**  $\pm 0.1\%$   
**Min. span required to ensure the accuracy:** 20 % of the nominal output range  
**Display accuracy:** Accuracy  $\pm 1$  digit (with 0.0 – 100.0 scaling)  
**Temp. coefficient:**  $\pm 0.015\%/^{\circ}\text{C}$  ( $\pm 0.008\%/^{\circ}\text{F}$ )  
**Response time:** Approx. 1 – 999 sec. variable (0 – 100 %)  
**Output memory at power OFF:** E<sup>2</sup>PROM (non-volatile memory)  
**Line voltage effect:**  $\pm 0.1\%$  over voltage range  
**Insulation resistance:**  $\geq 100\ \text{M}\Omega$  with 500 V DC  
**Dielectric strength:** 2000 V AC @1 minute (input to output to power to ground)

## STANDARDS & APPROVALS

**CE conformity:**  
EMC Directive (2004/108/EC)  
EMI EN 61000-6-4: 2007  
EMS EN 61000-6-2: 2005  
Low Voltage Directive (2006/95/EC)  
EN 61010-1: 2001  
Installation Category II  
Pollution Degree 2



## EXTERNAL VIEW

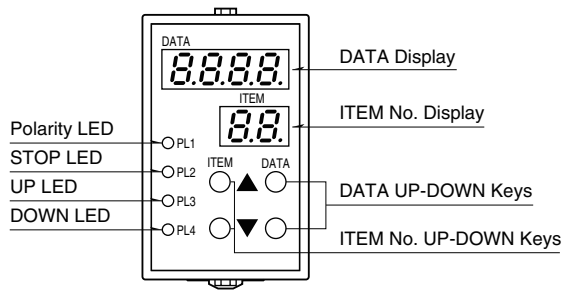

Refer to the instruction manual for detailed procedures.

## CONNECTION EXAMPLES

### ■ Used Independently

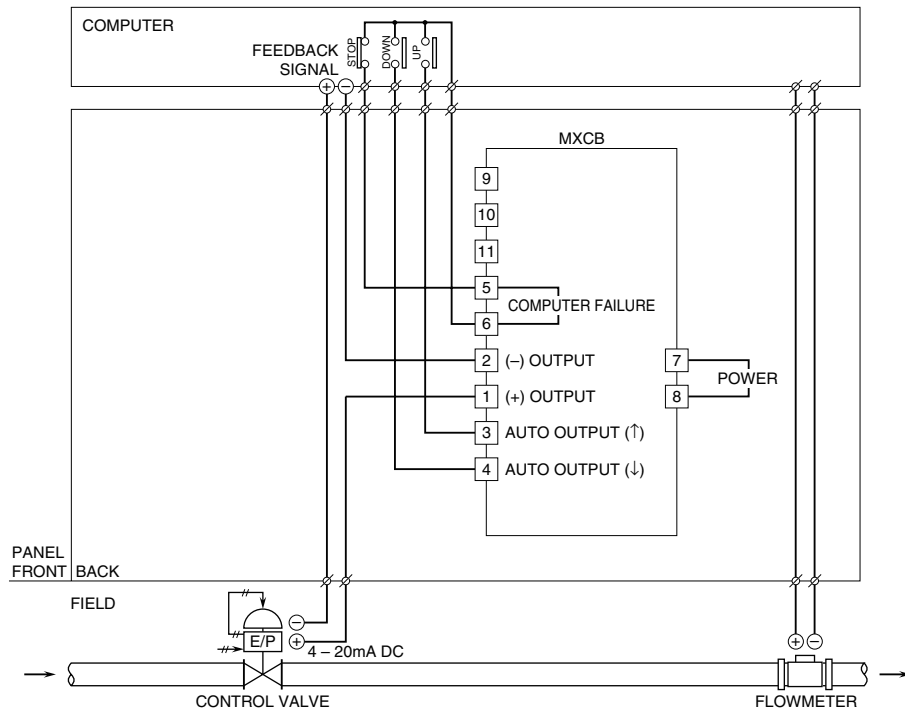

■ Used in Combination with ST/STL

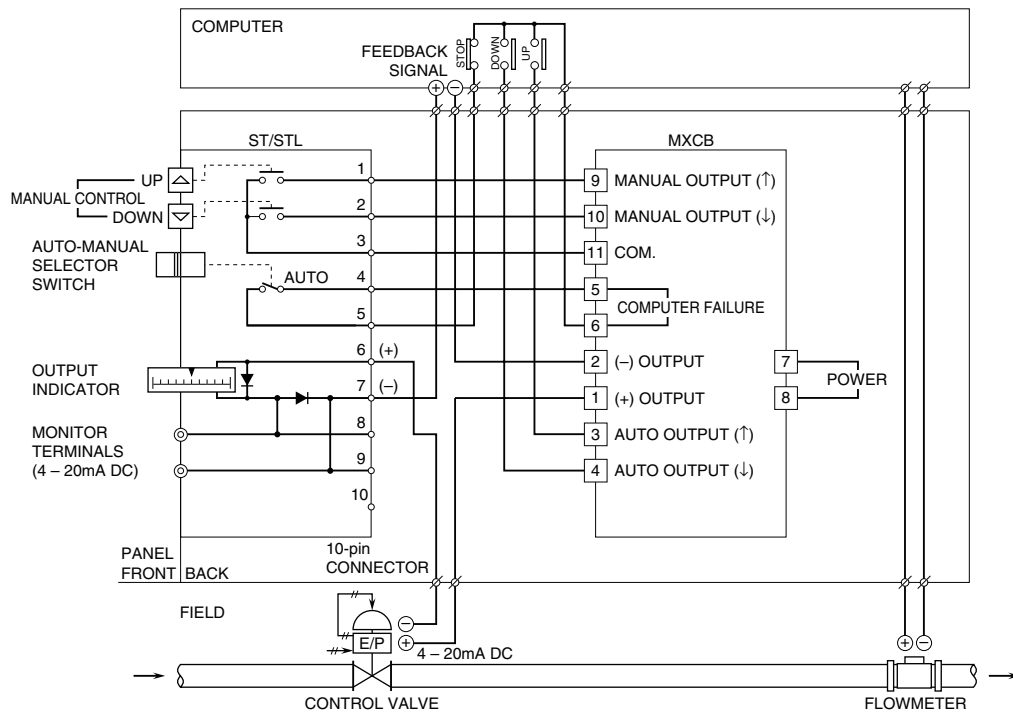

**EXTERNAL DIMENSIONS & TERMINAL ASSIGNMENTS unit: mm (inch)**

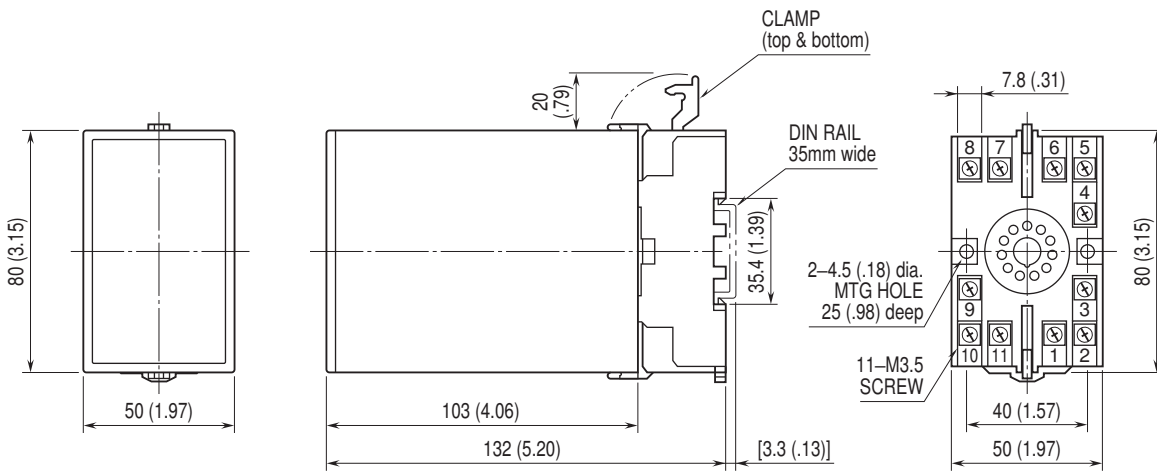

• When mounting, no extra space is needed between units.



## SCHEMATIC CIRCUITRY & CONNECTION DIAGRAM

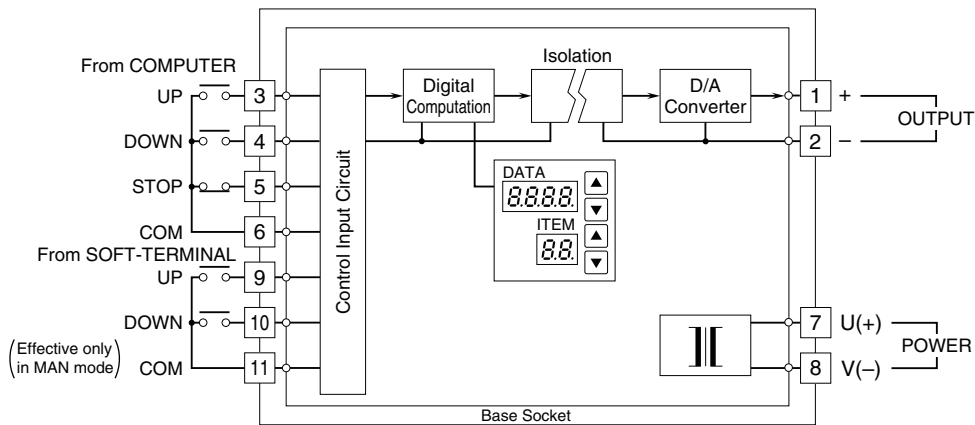

## FUNCTIONS

### ■ DEFAULT SETTING

#### • MXCB Used Independently

In normal operating mode, the MXCB responds to UP/DOWN signals from the computer in the preset ramp rate. If the computer fails, this will be detected as a "STOP" command and output will be held at the value prior to the breakdown. You can increase the output signal by closing across the terminals 9 – 11, and decrease it by closing 10 – 11. The output responds in the preset ramp rate.

#### • MXCB Used in Combination with ST/STL

In normal operating mode, the MXCB responds to UP/DOWN signals from the computer in the preset ramp rate. If the computer fails, the "STOP" command will override computer output and put the unit in the manual operation mode by the ST/STL. Using the top-mounted UP or DOWN key, output can be increased or decreased in the preset ramp rate. Output signal value can be read on the top-mounted indicator. For more precise control, use the monitor terminals. Also the computer input can be overridden with the AUTO/MANUAL selector on the Soft-Terminal. This is useful when you need to change the output quickly during automatic operation by the computer control.

COMMAND		TERM.	SIGNAL STATUS
Computer	UP	3-6	1 0 0 1 - - - -
	DOWN	4-6	0 1 0 1 - - - -
	STOP	5-6	1 1 1 1 0 0 0 0
ST/STL	UP	9-11	- - - - 1 0 0 1
	DOWN	10-11	- - - - 0 1 0 1
Output of the MXCB		1-2	↑ ↓ H H ↑ ↓ H H

[Keys] 1 : ON      0 : OFF      - : ON or OFF  
 H : Hold      ↑ : Increase      ↓ : Decrease



## SYSTEM CONFIGURATION EXAMPLES

- Analog Control Using Contact Closure Outputs from a Computer
- MXCB Independently    • MXCB – ST/STL Combination

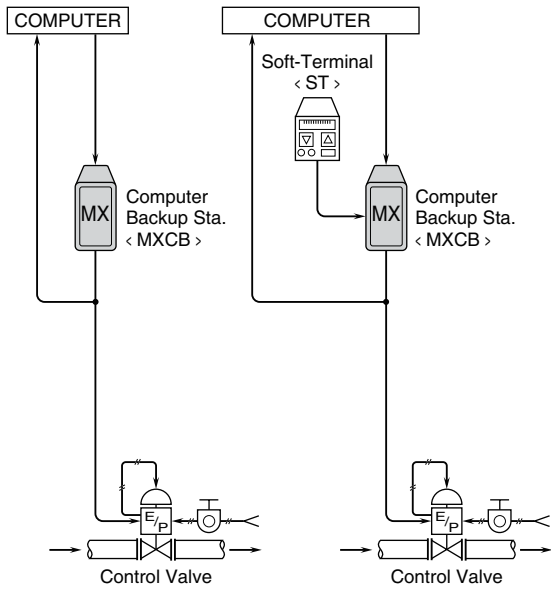

- Employing an Analog Controller in a DDC Control Loop
- MXCB – ST/STL Combination

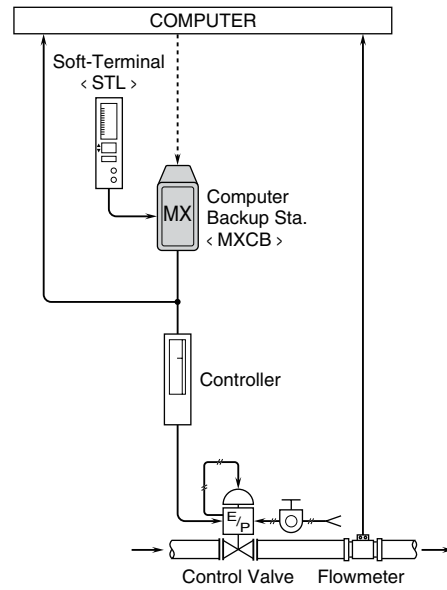

- Control Loop with Multiplex Transmission

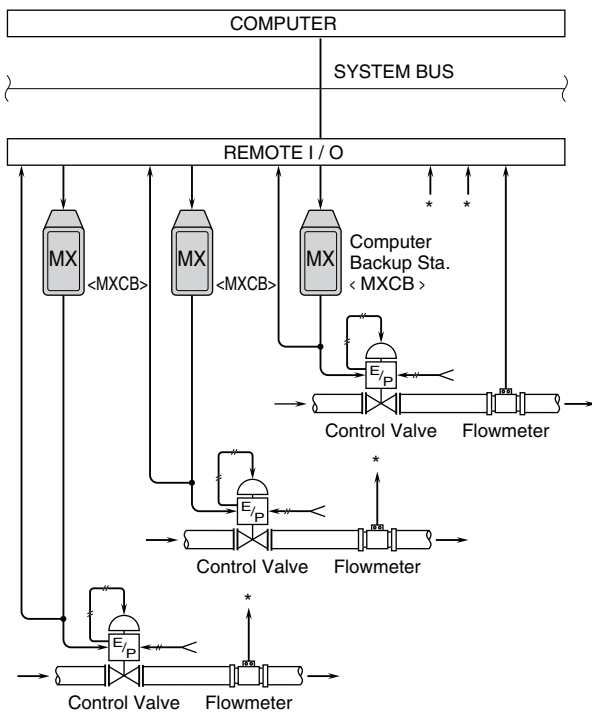

- Remote Control of an I/O Positioner with Switches

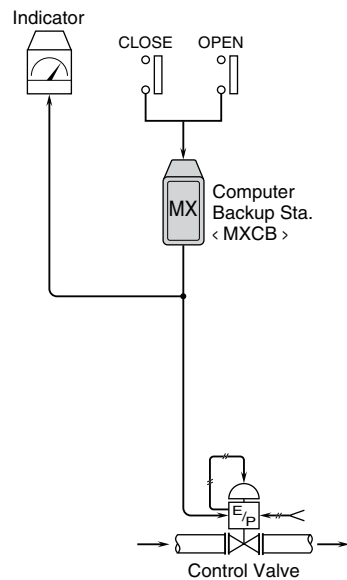

Specifications are subject to change without notice.

