

Plug-in Signal Conditioners MX-UNIT

ANALOG BACKUP STATION

(front configurable)

Functions & Features

- Manipulates control signals from a computer or DCS
- Manual control in case of computer/DCS failure
- Restarts at the last stored value before power failure
- Ramp rate adjustable
- Isolation between input and output

Typical Applications

- Computer and DCS backup applications
- Used as manual-auto controller

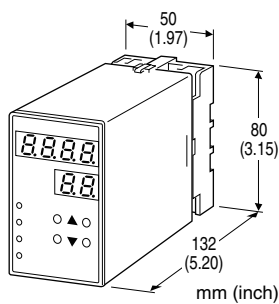

MODEL: MXAB-[1][2]-[3][4]

ORDERING INFORMATION

- Code number: MXAB-[1][2]-[3][4]
- Specify a code from below for each [1] through [4].
(e.g. MXAB-S1V1-M2/Q)
- Specify the specification for option code /Q
(e.g. /SET)

[1] INPUT

Voltage

- S1:** Range -1 - +1 V DC (Input resistance 100 kΩ min.)
- S2:** Range -10 - +10 V DC (Input resistance 1 MΩ min.)
- S3:** Range -30 - +30 V DC (Input resistance 1 MΩ min.)

[2] OUTPUT

Current

- Z1:** Range 0 - 20 mA DC (Load resistance 600Ω max.)

Voltage

- V1:** Range -1 - +1 V DC (Load resistance 1000Ω min.)
- V2:** Range -10 - +10 V DC (Load resistance 10kΩ min.)

[3] POWER INPUT

AC Power

M2: 100 - 240 V AC (Operational voltage range 85 - 264 V, 47 - 66 Hz)

DC Power

R3: 12 - 24 V DC

(Operational voltage range 10.8 - 26.4 V, ripple 10 %p-p max.)

P: 110 V DC

(Operational voltage range 85 - 150 V, ripple 10 %p-p max.)

[4] OPTIONS

blank: none

/Q: With options (specify the specification)

SPECIFICATIONS OF OPTION: Q

EX-FACTORY SETTING

/SET: Preset according to the Ordering Information Sheet
(No. ESU-1747)

RELATED PRODUCTS

- Resistor module (model: REM)
- Soft-Terminal (model: ST/STL)

GENERAL SPECIFICATIONS

Construction: Plug-in

Connection: M3.5 screw terminals

Housing material: Flame-resistant resin (black)

Isolation: Input to output to power

Ramp rate adjustment (MAN mode only): Approx. 1 - 999 sec.

■ DISPLAY

LED: 8 mm (.31") 7 segment, red

Number of display digits: 4 digits for DATA display; 2 digits for ITEM display

Scaling: -9999 to 9999

PV indication: Output signal in engineering unit

Overrange indication: LEDs blinking

Power saving mode: Displays turn off if the keys are untouched for a preset time period

LEDs: Red; the PL1 turns on with negative polarity.

Programming: Via front keys

- Scaled range
- Moving average
- Response time
- Trace back mode
- Initial value, Hi, Lo
- etc.

Refer to the instruction manual for detailed information.



INPUT SPECIFICATIONS

■ DC INPUT from the computer

Code S1: -1.00 - +1.00 V DC

Operational range: -1.15 - +1.15 V DC

Minimum increment: 10 mV

Code S2: -10.0 - +10.0 V DC

Operational range: -11.5 - +11.5 V DC

Minimum increment: 100 mV

Code S3: -30.0 - +30.0 V DC

Operational range: -34.5 - +34.5 V DC

Minimum increment: 100 mV

Notes:

-Set to the 100 % input voltage a larger value than that to the 0 % input voltage.

-Operational range is of -15 to +115 % or as indicated above.

Default setting:

Code S1: -1.00 - +1.00 V DC

Code S2: -10.0 - +10.0 V DC

Code S3: -30.0 - +30.0 V DC

■ **CONTACT INPUT:** TTL level (5V-CMOS level) or open collector/dry contact (saturation voltage \leq 1 V, sink current 0.5 mA)

Stop signal (input from the computer):

Switches AUTO/MAN modes.

UP/DOWN signals (input from the Soft-Terminal): Controls the analog output in MAN mode.

OUTPUT SPECIFICATIONS

• **DC Current:** 0.0 - 20.0 mA DC

Operational range: 0.0 - 24.0 mA DC

Minimum increment: 0.1 mA

Default setting: 4.0 - 20.0 mA DC

• **DC Voltage**

Code V1: -1.00 - +1.00 V DC

Operational range: -1.15 - +1.15 V DC

Minimum increment: 10 mV

Code V2: -10.0 - +10.0 V DC

Operational range: -11.5 - +11.5 V DC

Minimum increment: 100 mV

Note: Set to the 100 % output with a larger value than the 0 % output value.

Default setting:

Code V1: -1.00 - +1.00 V DC

Code V2: -10.0 - +10.0 V DC

INSTALLATION

Power Consumption

• **AC:** Approx. 10 VA

• **DC:** Approx. 3.5 W (150 mA at 24 V)

Operating temperature: -5 to +55°C (23 to 131°F)

Operating humidity: 30 to 90 %RH (non-condensing)

Mounting: Surface or DIN rail

Weight: 450 g (0.99 lbs)

PERFORMANCE in percentage of max. span

Accuracy: Input + output

Input: ± 0.05 %

Output: ± 0.05 %

Min. span required to ensure the accuracy:

20 % of the nominal I/O range

Display accuracy: Input accuracy ± 1 digit

(with 0.0 - 100.0 scaling)

Temp. coefficient: ± 0.015 %/°C (± 0.008 %/°F)

Response time: ≤ 0.5 sec. in AUTO (0 - 90 %)

Approx. 1 - 999 sec. variable in MAN (0 - 100 %)

Output memory at power OFF: E²PROM (non-volatile memory)

Line voltage effect: ± 0.1 % over voltage range

Insulation resistance: ≥ 100 M Ω with 500 V DC

Dielectric strength: 2000 V AC @1 minute (input to output to power to ground)

STANDARDS & APPROVALS

CE conformity:

EMC Directive (2004/108/EC)

EMI EN 61000-6-4: 2007

EMS EN 61000-6-2: 2005

Low Voltage Directive (2006/95/EC)

EN 61010-1: 2001

Installation Category II

Pollution Degree 2

Input to output to power - Basic insulation (300 V)



EXTERNAL VIEW

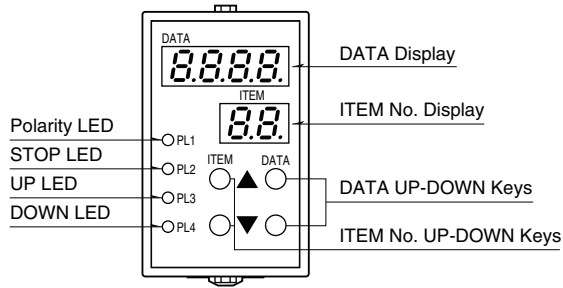

Refer to the instruction manual for detailed procedures.

CONNECTION EXAMPLES

■ Used Independently

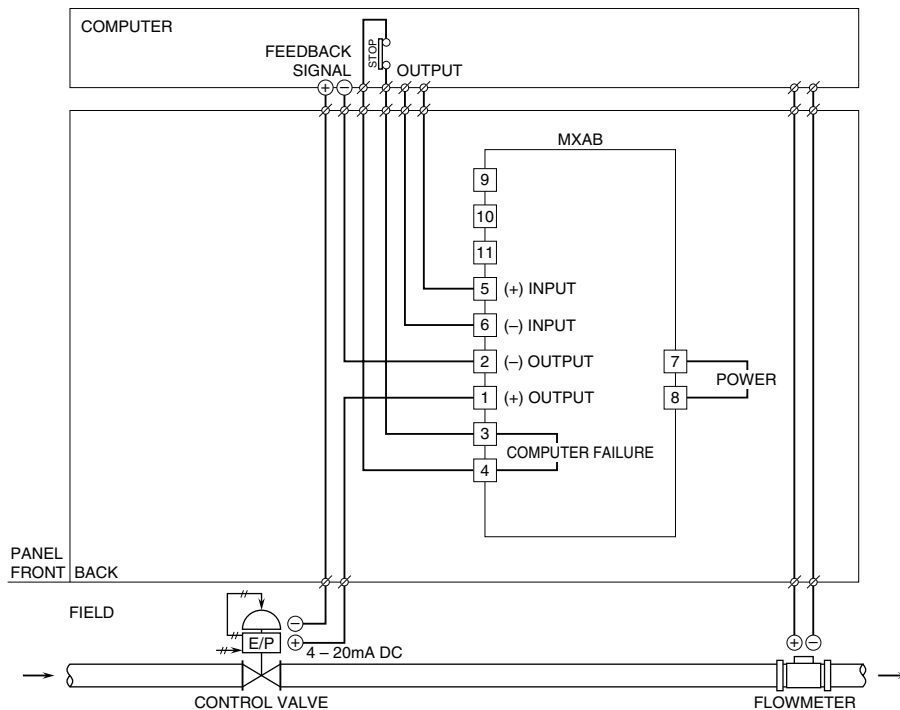

■ Used in Combination with ST/STL

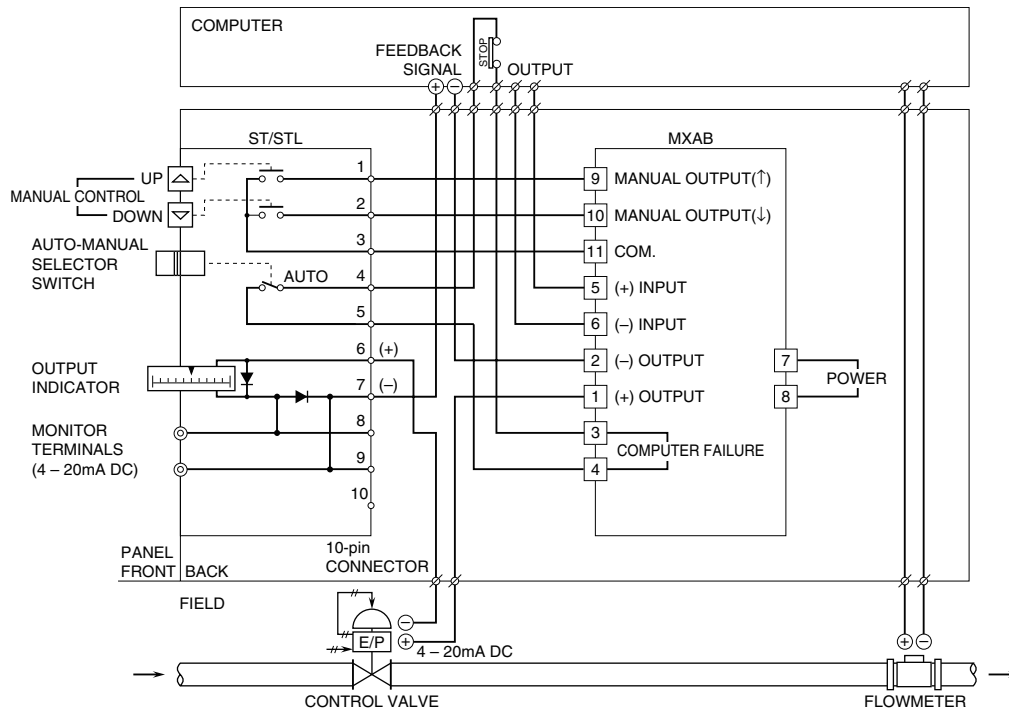

EXTERNAL DIMENSIONS & TERMINAL ASSIGNMENTS unit: mm (inch)

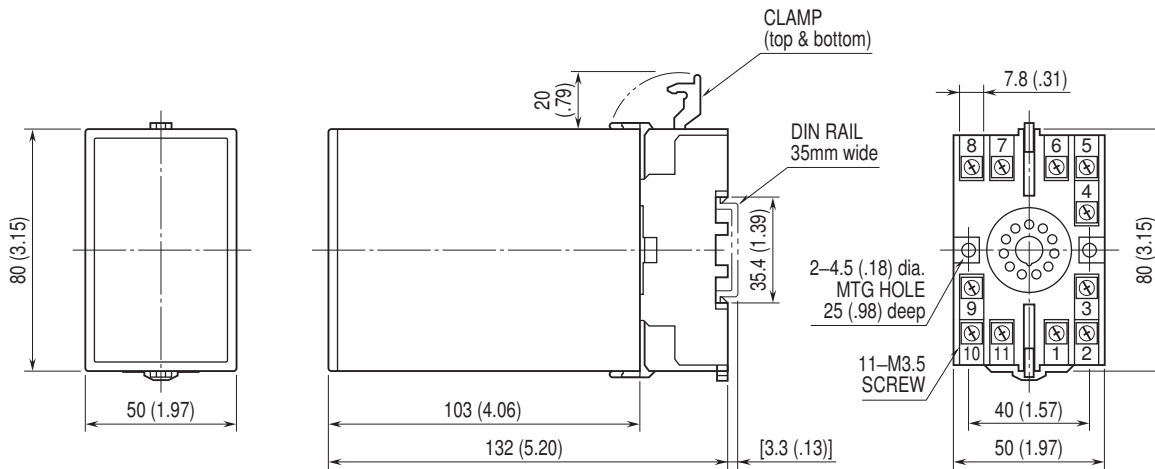

• When mounting, no extra space is needed between units.



SCHEMATIC CIRCUITRY & CONNECTION DIAGRAM

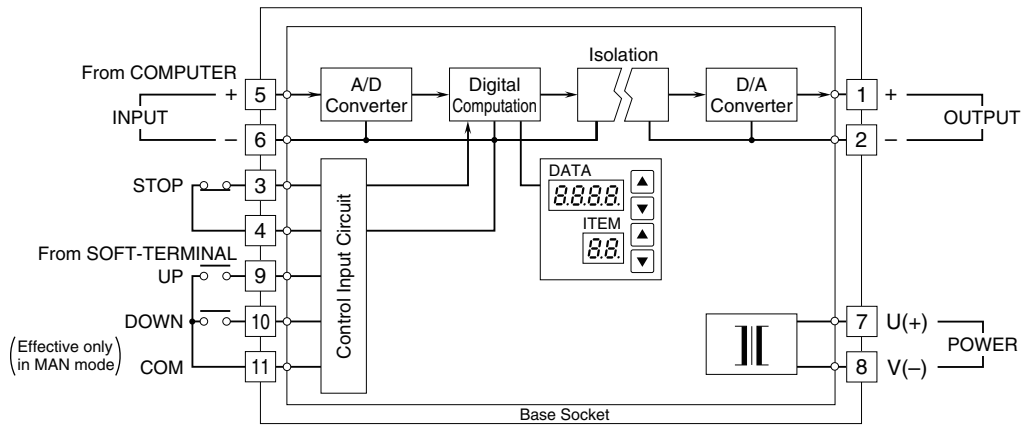

FUNCTIONS

■ Basic Operation (operation in default setting)

In normal operating mode, the MXAB responds proportionally to its input (the computer output) in the response time of less than 0.5 seconds.

If the computer fails, this will be detected as a "STOP" command and output will be held at the value prior to the breakdown. You can increase the output signal by closing across the terminals 9 – 11, and decrease it by closing 10 – 11. The output responds in the preset ramp rate.

COMMAND		TERM.	SIGNAL STATUS
Computer	DC Signal	5 – 6	↑ ↓
	STOP	3 – 4	1 1 0 0 0 0 0 0
ST/STL	UP	9 – 11	– – – – 1 0 0 1
	DOWN	10 – 11	– – – – 0 1 0 1
Output of the MXAB		1 – 2	↑ ↓ H H ↑ ↓ H H
[Keys] 1 : ON 0 : OFF – : ON or OFF			
H : Hold ↑ : Increase ↓ : Decrease			

■ Output after the Switching from AUTO Mode to MANUAL Mode

The output changes according to the ITEM 13.

When the ITEM 13 is 0, the output is the value retroactive to the preset time period in the ITEM 15.

When the ITEM 13 is 1, the output is the value preset in the ITEM 14.

■ Output Stored at the Loss of Power

When the ITEM 17 is 0, the output value at the loss of power is stored.

When the ITEM 15 is other than 0, the output value retroactive to the preset time period in the ITEM 15 is stored.

When the Stop signal is in MANUAL mode at power recovery, the output is the stored value.

■ Output at Start-up of the MXAB

The following shows the output value at start-up of the MXAB and after switching of mode of the Stop.

• Output when Stop-mode is AUTO at Start-up of the MXAB

MANUAL control mode (ITEM 13)	Trace-back time (ITEM 15)	Output stored at loss of power (ITEM 17)	Before switching of Stop-mode (AUTO)	Output after switching of the Stop-mode from AUTO to MANUAL	
				Before Trace-back time passes	After Trace-back time passed
1 (Fixed value mode)	No effect	1: Enable	Proportional to input value	Fixed value preset in the ITEM 14	
		0: Disable		The value at the time of the Stop-mode switched	
0 (Trace-back mode)	Other than 0	1: Enable		The value stored at the loss of power	The value retroactive to the preset time period in the ITEM 15
		0: Disable		The value preset in the ITEM 18	

• Output when Stop-mode is MANUAL at Start-up of the MXAB

MANUAL control mode (ITEM 13)	Trace-back time (ITEM 15)	Output stored at loss of power (ITEM 17)	Before switching of Stop-mode (MANUAL)	Output after the Stop-mode is switched back from AUTO to MANUAL	
				Before Trace-back time passes	After trace-back time passed
1 (Fixed value mode)	Don't care	1: Enable	The value stored at the loss of power	Fixed value preset in the ITEM 14	
		0: Disable	The value preset in the ITEM 18		
0 (Trace-back mode)	0	1: Enable	The value stored at the loss of power	The value at the time of the Stop-mode switched	
		0: Disable	The value preset in the ITEM 18		
	Other than 0	1: Enable	The value stored at the loss of power	The value stored at the loss of power	The value retroactive to the preset time period in the ITEM 15
		0: Disable	The value preset in the ITEM 18	The value preset in the ITEM 18	

■ MXAB Used in Combination with ST/STL

In normal operating mode, the MXAB responds proportionally to its input (the computer output) in the response time of less than 0.5 seconds.

If the computer fails, the "STOP" command will override computer output and put the unit in the manual operation mode by the ST/STL. Using the top-mounted UP or DOWN key, output can be increased or decreased in the preset ramp rate. Output signal value can be read on the top-mounted indicator. For more precise control, use the monitor terminals.

Also the computer input can be overridden with the AUTO-MANUAL selector on the Soft-Terminal.



SYSTEM CONFIGURATION EXAMPLES

- Holding and Manual Backup in Case of Computer Failure
- MXAB Independently
- MXAB – ST/STL Combination

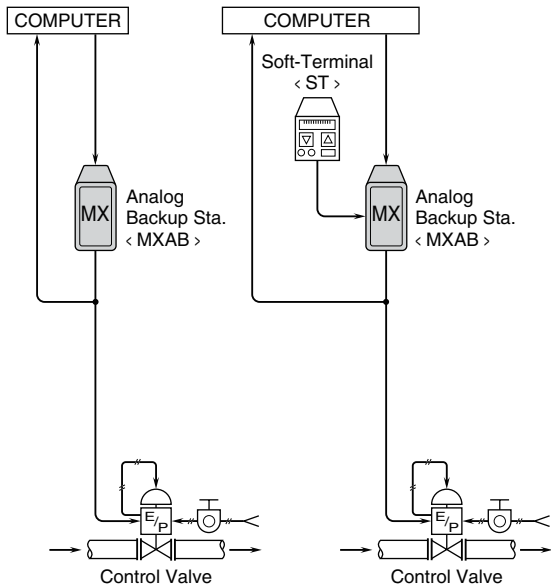

- Field Backup for a DDC Control Loop
- MXAB – ST/STL Combination

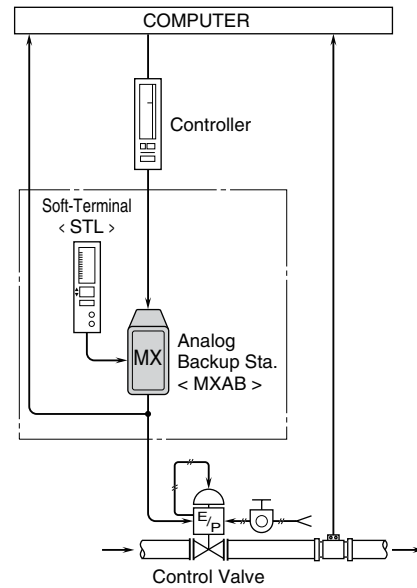

- Field Backup for Computer Outputs

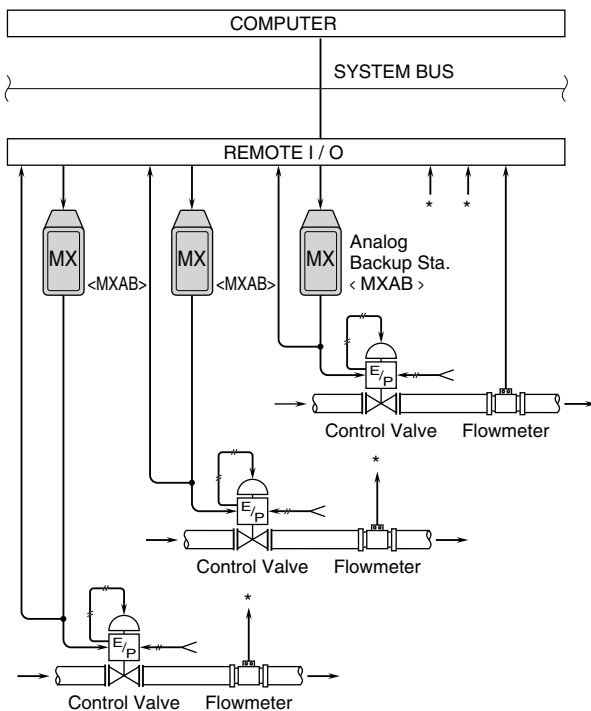

- Operator Control Station

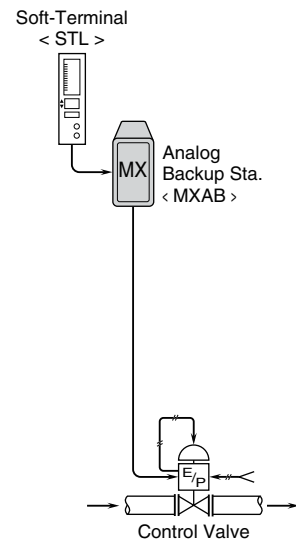

Specifications are subject to change without notice.

