

Plug-in Signal Conditioners M-UNIT

RATIO TRANSMITTER

(with output bias; thumbwheel switch adjustments)

Functions & Features

- Providing precise matching of DC control signals to final control elements in open- or closed-loop systems
- Monitor jacks provided for ratio & bias adjustments
- Ratio adjustable from 0.1 to 3.99
- Bias adjustable within $\pm 99\%$
- High-density mounting

Typical Applications

- Ratio control for air/fuel flows or for two flows
- Gain calculation for manipulated variable from a controller
- Large scale signal span adjustment

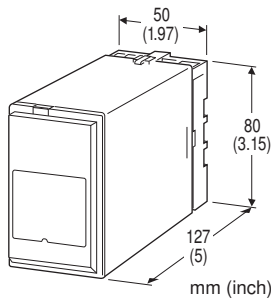

MODEL: MRTD-[1]-[2][3]-[4][5]

ORDERING INFORMATION

- Code number: MRTD-[1]-[2][3]-[4][5]
Specify a code from below for each [1] through [5].
(e.g. MRTD-S-AA-R/Q)
- Special input and output ranges (For codes Z & 0)
- Specify the specification for option code /Q
(e.g. /C01/S01)

[1] OUTPUT CHARACTERISTICS

- S: Positive
- R: Negative

[2] INPUT

Current

- A: 4 - 20 mA DC (Input resistance 250 Ω)
- A1: 4 - 20 mA DC (Input resistance 50 Ω)
- B: 2 - 10 mA DC (Input resistance 500 Ω)
- C: 1 - 5 mA DC (Input resistance 1000 Ω)
- D: 0 - 20 mA DC (Input resistance 50 Ω)
- E: 0 - 16 mA DC (Input resistance 62.5 Ω)
- F: 0 - 10 mA DC (Input resistance 100 Ω)

- G: 0 - 1 mA DC (Input resistance 1000 Ω)
- H: 10 - 50 mA DC (Input resistance 100 Ω)
- J: 0 - 10 μ A DC (Input resistance 1000 Ω)
- K: 0 - 100 μ A DC (Input resistance 1000 Ω)
- GW: -1 - +1 mA DC (Input resistance 1000 Ω)
- FW: -10 - +10 mA DC (Input resistance 100 Ω)
- Z: Specify current (See INPUT SPECIFICATIONS)

Voltage

- 1: 0 - 10 mV DC (Input resistance 10 k Ω min.)
- 15: 0 - 50 mV DC (Input resistance 10 k Ω min.)
- 16: 0 - 60 mV DC (Input resistance 10 k Ω min.)
- 2: 0 - 100 mV DC (Input resistance 100 k Ω min.)
- 3: 0 - 1 V DC (Input resistance 1 M Ω min.)
- 4: 0 - 10 V DC (Input resistance 1 M Ω min.)
- 5: 0 - 5 V DC (Input resistance 1 M Ω min.)
- 6: 1 - 5 V DC (Input resistance 1 M Ω min.)
- 4W: -10 - +10 V DC (Input resistance 1 M Ω min.)
- 5W: -5 - +5 V DC (Input resistance 1 M Ω min.)
- 0: Specify voltage (See INPUT SPECIFICATIONS)

[3] OUTPUT

Current

- A: 4 - 20 mA DC (Load resistance 750 Ω max.)
- B: 2 - 10 mA DC (Load resistance 1500 Ω max.)
- C: 1 - 5 mA DC (Load resistance 3000 Ω max.)
- D: 0 - 20 mA DC (Load resistance 750 Ω max.)
- E: 0 - 16 mA DC (Load resistance 900 Ω max.)
- F: 0 - 10 mA DC (Load resistance 1500 Ω max.)
- G: 0 - 1 mA DC (Load resistance 15 k Ω max.)
- Z: Specify current (See OUTPUT SPECIFICATIONS)

Voltage

- 1: 0 - 10 mV DC (Load resistance 10 k Ω min.)
- 2: 0 - 100 mV DC (Load resistance 100 k Ω min.)
- 3: 0 - 1 V DC (Load resistance 100 Ω min.)
- 4: 0 - 10 V DC (Load resistance 1000 Ω min.)
- 5: 0 - 5 V DC (Load resistance 500 Ω min.)
- 6: 1 - 5 V DC (Load resistance 500 Ω min.)
- 4W: -10 - +10 V DC (Load resistance 2000 Ω min.)
- 5W: -5 - +5 V DC (Load resistance 1000 Ω min.)
- 0: Specify voltage (See OUTPUT SPECIFICATIONS)

[4] POWER INPUT

AC Power

- B: 100 V AC
- C: 110 V AC
- D: 115 V AC
- F: 120 V AC
- G: 200 V AC
- H: 220 V AC
- J: 240 V AC

DC Power



S: 12 V DC
 R: 24 V DC
 V: 48 V DC
 P: 110 V DC

[5] OPTIONS

blank: none

/Q: With options (specify the specification)

SPECIFICATIONS OF OPTION: Q (multiple selections)

COATING (For the detail, refer to M-System's web site.)

/C01: Silicone coating

/C02: Polyurethane coating

/C03: Rubber coating

TERMINAL SCREW MATERIAL

/S01: Stainless steel

GENERAL SPECIFICATIONS

Construction: Plug-in

Connection: M3.5 screw terminals

Screw terminal: Chromated steel (standard) or stainless steel

Housing material: Flame-resistant resin (black)

Isolation: Input to output to power

Overrange output: Approx. -10 to +120 % at 1 - 5 V

Zero adjustment: -5 to +5 % (front)

Span adjustment: 95 to 105 % (front)

Equation: $X_o = KX_i + B$ for positive ratio;

$X_o = F - KX_i + B$ for negative ratio

where X_o : output (%)

X_i : input (%)

K : ratio

(0.1 - 3.99 conformance range)

B : bias (-99 - +99 %)

F : 100 %

(factory setting: $K = 1$, $B = 0$ %)

Ratio/bias adjustment: 3-digit thumbwheel switches

INPUT SPECIFICATIONS

■ **DC Current:**

Shunt resistor attached to the input terminals (0.5 W)

Specify input resistance value for code Z.

■ **DC Voltage:** -300 - +300 V DC

Minimum span: 3 mV

Offset: Max. 1.5 times span

Input resistance

Span 3 - 10 mV : ≥ 10 k Ω

Span 10 - 100 mV : ≥ 10 k Ω

Span 0.1 - 1 V : ≥ 100 k Ω

Span ≥ 1 V : ≥ 1 M Ω

OUTPUT SPECIFICATIONS

■ **DC Current:** 0 - 20 mA DC

Minimum span: 1 mA

Offset: Max. 1.5 times span

Load resistance: Output drive 15 V max.

■ **DC Voltage:** -10 - +12 V DC

Minimum span: 5 mV

Offset: Max. 1.5 times span

Load resistance: Output drive 10 mA max.; 5 mA for negative voltage output; at ≥ 0.5 V

INSTALLATION

Power input

• **AC:** Operational voltage range: rating ± 10 %, 50/60 ± 2 Hz, approx. 2 VA

• **DC:** Operational voltage range: rating ± 10 %, or 85 - 150 V for 110 V rating (ripple 10 % p-p max.)

Approx. 2 W (80 mA at 24 V)

Operating temperature: -5 to +60°C (23 to 140°F)

Operating humidity: 30 to 90 %RH (non-condensing)

Mounting: Surface or DIN rail

Weight: 400 g (0.88 lb)

PERFORMANCE in percentage of span

Ratio setting accuracy: ± 0.2 %

(at 0.1 - 3.99 conformance range)

Bias setting accuracy: ± 1 %

Accuracy: ± 0.3 % (with ratio = 1, bias = 0 %)

Temp. coefficient: ± 0.015 %/°C (± 0.008 %/°F)

Response time: ≤ 0.5 sec. (0 - 90 %)

Line voltage effect: ± 0.1 % over voltage range

Insulation resistance: ≥ 100 M Ω with 500 V DC

Dielectric strength: 2000 V AC @1 minute (input to output to power to ground)



EXTERNAL VIEW

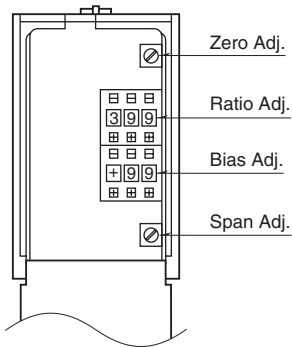

DIMENSIONS unit: mm (inch)

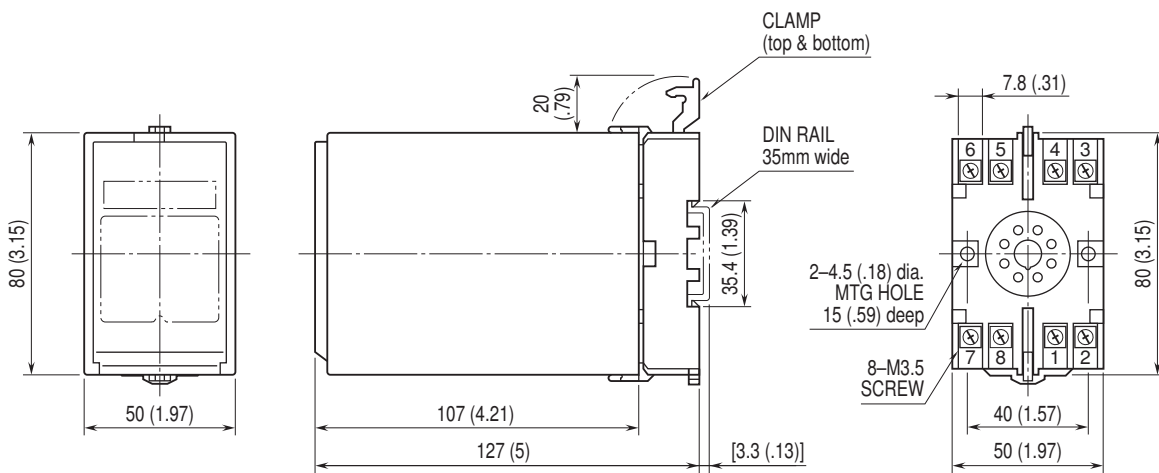

• When mounting, no extra space is needed between units.

TERMINAL ASSIGNMENTS unit: mm (inch)

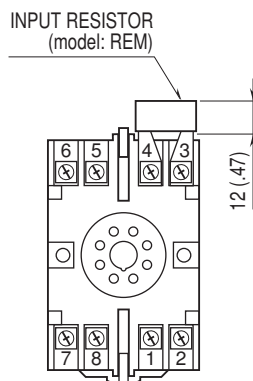

Input shunt resistor attached for current input.

SCHEMATIC CIRCUITRY & CONNECTION DIAGRAM

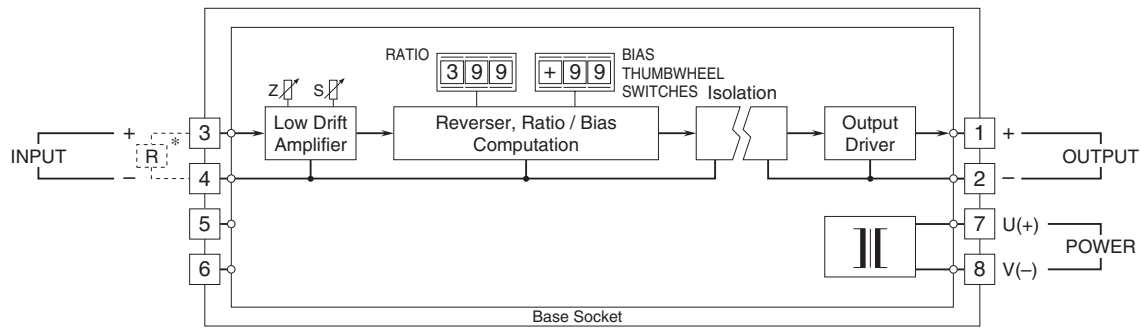

*Input shunt resistor attached for current input.

INPUT-OUTPUT RELATION EXAMPLES

[Examples of Positive Gain]

- ① K = 1 B = 50%
- ② K = 0.5 B = 50%
- ③ K = 2 B = 0
- ④ K = 1 B = 0
- ⑤ K = 0.5 B = 0
- ⑥ K = 1 B = -50%

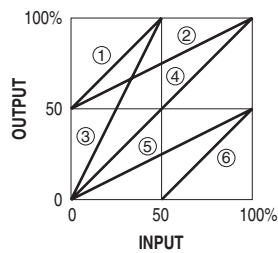

[Examples of Negative Gain]

- ① K = 1 B = 50%
- ② K = 0.5 B = -50%
- ③ K = 2 B = 0
- ④ K = 1 B = 0
- ⑤ K = 0.5 B = 0
- ⑥ K = 1 B = -50%

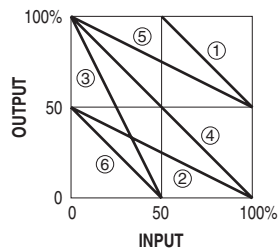

Specifications are subject to change without notice.

