

Final Control Elements

MINI-TOP ELECTRONIC ACTUATOR

(rotary type; CC-Link)

Functions & Features

- Small-size control valve actuator
- Direct connection to CC-Link capable PLC and other devices on the same network
- Easy wired
- Uploading device information via CC-Link for maintenance purpose
- 1/1000 high resolution

Typical Applications

- Actuator for automatic control valve in pilotplants
- Air-conditioning in buildings or plants
- Micro-flow control for pharmaceutical injection
- For small-size control valves

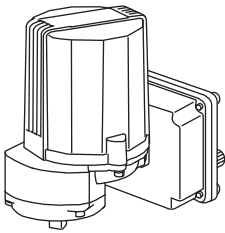

MODEL: MRP4C-[1][2]-OR[3]

ORDERING INFORMATION

- Code number: MRP4C-[1][2]-OR[3]
- Specify a code from below for each [1] through [3].
(e.g. MRP4C-14-OR/Q)
- Specify the specification for option code /Q
(e.g. /SET)

[1] SPAN

- 1: 45 to 90 degrees
2: 90 to 180 degrees

[2] OPERATION TIME, TORQUE

- 4: 7 seconds / 90°, 5 N·m
5: 13 seconds / 90°, 5 N·m

CE MARKING

0: Without

POWER INPUT

DC Power

R: 24 V DC

(Operational voltage range 24 V ±10 %, ripple 10 %p-p max.)

[3] OPTIONS

blank: none

/Q: With options (specify the specification)

SPECIFICATIONS OF OPTION: Q

EX-FACTORY SETTING

/SET: Preset according to the Ordering Information Sheet
(No. ESU-4865)

GENERAL SPECIFICATIONS

Degree of protection: IP66

Operation at a communication error: Turn counterclockwise, clockwise or stop (DIP SW selectable; factory set to 'stop')

Note: Counterclockwise or clockwise if seen from the cover

Power circuit connection: 4-core microconnector, male

Power cable: Cable with connector (e.g. OMRON XS2F or XS2WD42)

Transmission cable: Conforms to CC-Link
(e.g. Woodhead CC-Link Micro-Change)

Housing material: Cast aluminum

Drive: Stepping motor

Position detection: Potentiometer

Deadband: 0.1 - 1.9 % adjustable (factory set to 1.5 %)

Restarting timer: 0 - 10 sec. adjustable

(factory set to 1.5 sec.)

Isolation: Housing or communication to power

Zero adjustment: 0 - 25 %

Span adjustment: 50 - 100 %

Protective functions: Overload protection

Status indicator LED: Red light blinks in 2 sec. intervals in normal operations; blinks in 0.5 sec. intervals when a foreign object is detected mechanically caught inside.

Manual operating handle: Not available

CC-Link COMMUNICATION

Protocol: CC-Link V1.10

Device type: Remote device station

Station No. setting: Rotary switch; 1 - 64

Required node: 1

Baud rate setting: Rotary switch

L RUN indicator: Red LED

L ERR. indicator: Red LED



OUTPUT SPECIFICATIONS

■ Operation Time & Torque (at rated power voltage)

MRP4C-x4: 7 sec. / 90°; torque 5 N·m (3.69 ft·lbf)

MRP4C-x5: 13 sec. / 90°; torque 5 N·m (3.69 ft·lbf)

INSTALLATION

Power consumption

•DC: Approx. 0.7 A

Operating temperature: -5 to +55°C (23 to 131°F)

Operating humidity: 30 to 85 %RH (non-condensing)

Vibration: 0.5 G (4.9 m/s²) max.

Mounting position: All directions

Do not mount the actuator with its output stem or cable connector on the upside if the actuator is to be exposed to dripping water.

Weight: 1.4 kg (3.1 lb)

PERFORMANCE

Resolution: 1/1000 or 0.09°, whichever is greater (deadband set to 0.1 %)

Insulation resistance: ≥ 100 MΩ with 100 V DC

Dielectric strength: 100 V AC @ 1 minute
(housing or communication to power)

COMMUNICATIONS

■ MASTER to SLAVE

DATA TYPE	ADDRESS	FUNCTION	DETAIL
Bit	RY0	Forced Closed Position Input *1	0 : Disable 1 : Position = 0%
	RY1	Forced Open Position Input *1	0 : Disable 1 : Position = 100%
	RY2		
	RY3		
	RY4		
	RY5		
	RY6		
	RY7		
	RY8	Enable Target Position Input	0 : Disable 1 : Enable
	RY9		
	RYA	Reset Motor Deadlock Alarm	Motor deadlock alarm is cancelled when '1' is set.
	RYB	Clear Motor Starting Counter	Motor starting counter is reset to 0 when '1' is set.
	RYC	Clear Motor Reversing Counter	Motor reversing counter is reset to 0 when '1' is set.
	RYD	Clear Accumulated Running Distance	Accumulated running distance is reset to 0 when '1' is set.
	RYE		
RYF			
Word	RWw0	Target Position Input	Signed, 0.01% increments (e.g. 100 = 1.00%) Valid only when Enable Target Position Input is enabled.
	RWw1		
	RWw2		
	RWw3		

*1. Valid regardless of the RY8 (Enable Target Position Input) status. Stopped when '1' is set both at RY0 and RY1.



■ SLAVE to MASTER

DATA TYPE	ADDRESS	FUNCTION	DETAIL
Bit	RX0		
	RX1		
	RX2		
	RX3		
	RX4		
	RX5		
	RX6		
	RX7		
	RX8	Motor Deadlock Alarm	0 : Normal 1 : Overload or other deadlock alarm
	RX9	Target Position Input Error	0 : Normal 1 : Out of range from -0.5 to +100.5%
	RXA	System Error	0 : Normal 1 : Memory or other system error
	RXB	Control Status	0 : Remote (CC-Link) 1 : Manual
	RXC		
	RXD		
	RXE		
RXF			
Word	RWr0	Position Output	Signed, 0.01% increments (e.g. 100 = 1.00%)
	RWr1	Motor Starting Counter *2	1 count per every 100 starting actions
	RWr2	Motor Reversing Counter *2	1 count per every 100 reversing actions
	RWr3	Accumulated Running Distance (%) *2	1 count per running 100% distance every time

*2. When the count reaches 65535, the value is held until it is reset.

DIMENSIONS unit: mm (inch)

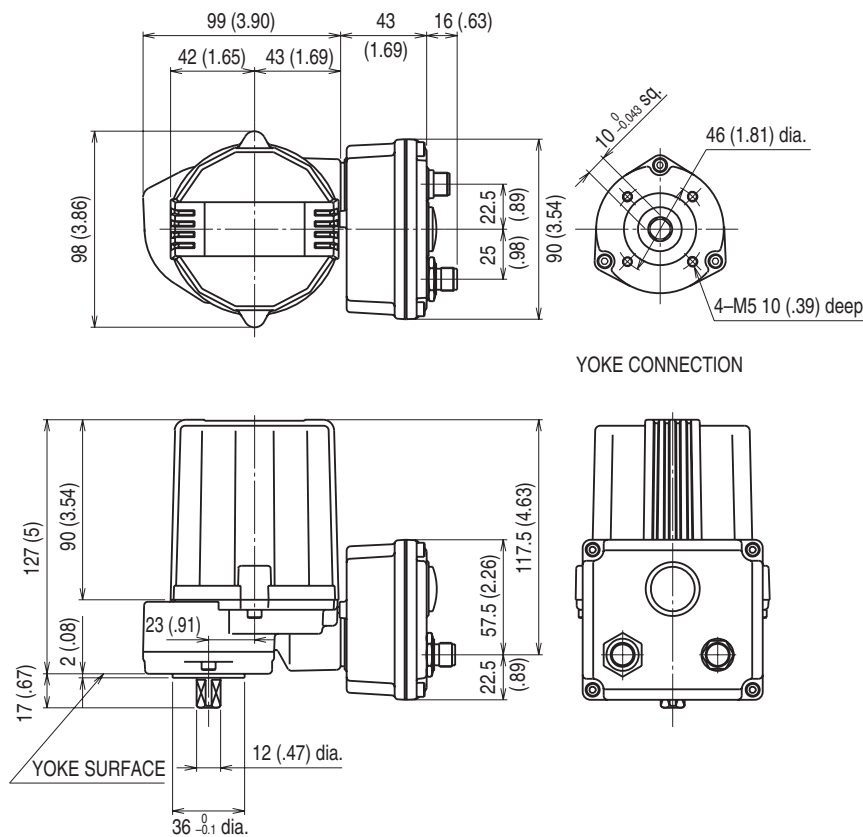

SCHEMATIC CIRCUITRY

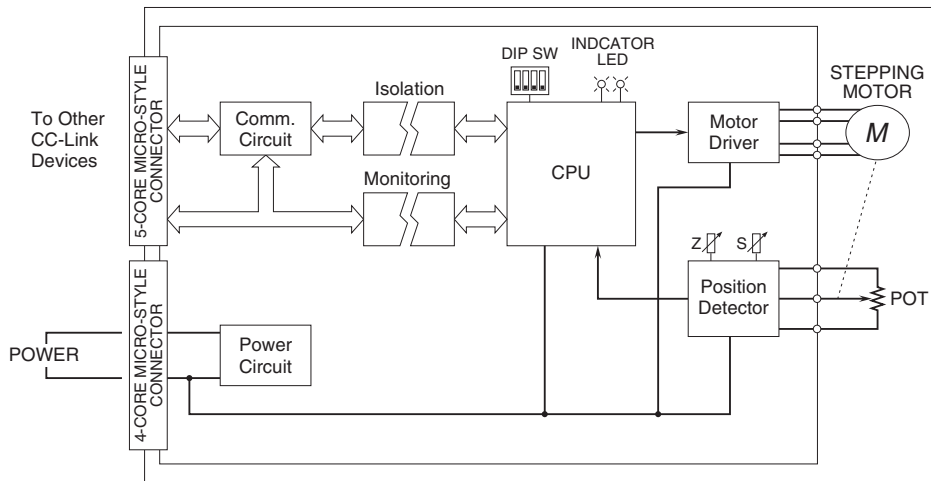

Specifications are subject to change without notice.

