

Limit Alarms M-PAC

AC INPUT LIMIT ALARM

MODEL MP1600-1623

MODEL & SUFFIX CODE SELECTION

MP16□□-□□/□

MODEL _____

INPUT TYPE _____

6 : AC current or voltage

RELAY CONTACT OUTPUT _____

0 : Single (Hi) trip, non-latching

1 : Single (Hi) trip, latching

2 : Dual (Hi/Lo) trip, non-latching

SETPOINT CONTROL _____

0 : Front-accessed three-turn screwdriver adjust.

2 : Remote dial connections (total resistance 1k – 100kΩ)

3 : DC programmable (0 – 1V)

INPUT RANGE _____

Current	Voltage
AA : 0 – 10mA AC	A1 : 0 – 100mV AC
AB : 0 – 50mA AC	A2 : 0 – 500mV AC
AC : 0 – 100mA AC	A3 : 0 – 1V AC
AD : 0 – 500mA AC	A4 : 0 – 5V AC
AZ : Specify current*	A5 : 0 – 10V AC
	A6 : 0 – 120V AC
	A7 : 0 – 150V AC
	A8 : Specify voltage*

*0% input must be 0mA or 0V.

POWER INPUT _____

F : 120V AC

J : 240V AC

R : 24V DC

S : 12V DC

OPTIONS _____

H : Latching operation for dual trip (162X only);
Reset at power off (5 seconds min.)

R : Reversed relay sense

T : Transmitter output (0 – 1V DC)

V : Relay drive voltage output

X : Lo-trip sense for single trip; Lo/Lo for dual trip

Y : Hi/Hi-trip sense for dual trip (162X only)

Functions & Features

- Accepting AC current and voltage inputs and providing relay contact closure(s) at a preset input level
- Single, latching or dual setpoint • Failsafe operation available • Deadband adjustable from 1 to 100%
- Indicator LED provided

Typical Applications

- Annunciator • Various alarm applications

GENERAL SPECIFICATIONS

Construction: plug-in

Connection: M3.5 screw terminals on base socket

Housing material: flame-resistant resin (black)

Isolation: input to output to power
(non-isolated between I/O with Option V)

Zero/span adjustments: ±5% (front)

Setpoint adjustments: front accessed three-turn screwdriver, remote dial potentiometer or DC input

Deadband adjustments: front accessed single-turn screwdriver; 1 – 100%

Front LEDs: red lights turn on at a tripped condition

Power ON timer: relays de-energized for approx. 2 seconds after power is turned on.

ORDERING INFORMATION

Specify code number and variables.

- **Code number** (e.g. MP1600-A6-F/T/V)
- **Special input range** (For codes AZ & A8)



INPUT & OUTPUT**INPUT**

Frequency: 40 Hz min., 1 kHz max. with 100% input

• **AC Current:** 0 – 1A AC; input resistor incorporated

Minimum span: 1mA

Input resistance

Input	Input Resistance
≥1mA, <500mA	: 10 (Ω)
≥500mA, <1A	: 1
1A	: 0.5

• **AC Voltage:** 0 – 250V AC

Minimum span: 50mV

Input resistance

Input	Input Resistance
≥50mV, <5V	: 100k (Ω)
≥5V	: 1M

REMOTE SETPOINT INPUT

MP16X2: potentiometer; any value of 1k – 100kΩ; excitation 4V

MP16X3: 0 – 1V DC

RELAY CONTACT OUTPUT

• **Single/Latching:** isolated DPDT relay; de-energized at trip

• **Dual:** isolated SPDT relay; energized at trip

Rating: 120V AC @3A (cosφ=1)
30V DC @3A (resistive load)

Relay life

Electrical: 10⁵ cycles

Mechanical: 10⁷ cycles

For maximum relay life with inductive loads, external protection is recommended.

■ **VOLTAGE OUTPUT (Option V):** 24V DC average;
Drives 1.2kΩ or greater coil impedance

■ **TRANSMITTER OUTPUT (Option T):** 0 – 1V DC;
1mA max. (setpoint and process input)

INSTALLATION**Power input**

AC: rating ±10%, 50/60 ±2 Hz, approx. 2VA

DC: rating ±10% (ripple 10% p-p max.)
80mA at 24V, 160mA at 12V

Operating temperature: -5 to +60°C (23 to 140°F)

Storage temperature: -20 to +85°C (-5 to +185°F)

Operating humidity: 30 to 90% RH (non-condensing)

Mounting: surface (DIN rail available for 11-pin base)

Dimensions

11-pin base: W50×H80×D132 mm
(1.97"×3.15"×5.20")

See General Spec. Sheet Figure A.

20-pin base: W80×H101×D136 mm
(3.15"×3.98"×5.35")

See General Spec. Sheet Figure B.

Weight: 400 g (0.88 lbs)

PERFORMANCE in percentage of span

Repeatability: ±0.2%

Temp. coefficient: ±0.05%/°C (±0.027%/°F)

Response time: 100 milliseconds, typical

Common mode rejection

60 Hz: greater than 120 dB

DC: greater than 140 dB

Line voltage effect: ±0.1% over voltage range

Insulation resistance: ≥100MΩ with 500V DC

Dielectric strength: 1000V AC @1 minute

(input to output to power)

2000V AC @1 minute (output to ground)



BLOCK DIAGRAM

■ SINGLE / LATCHING OUTPUT

• 11-pin Base

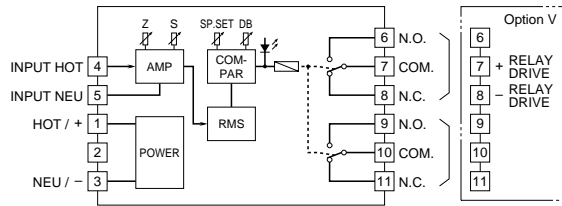

• 20-pin Base

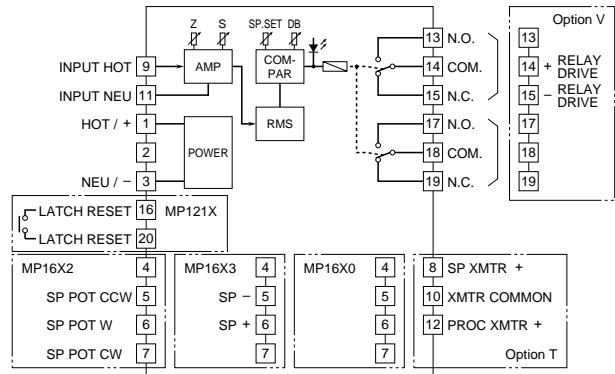

■ DUAL OUTPUT

• 11-pin Base

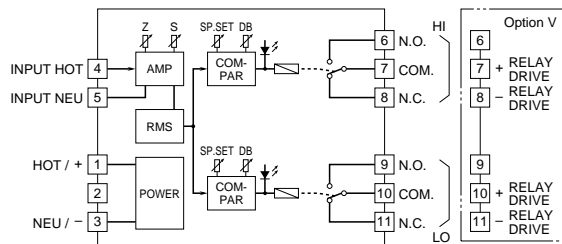

• 20-pin Base

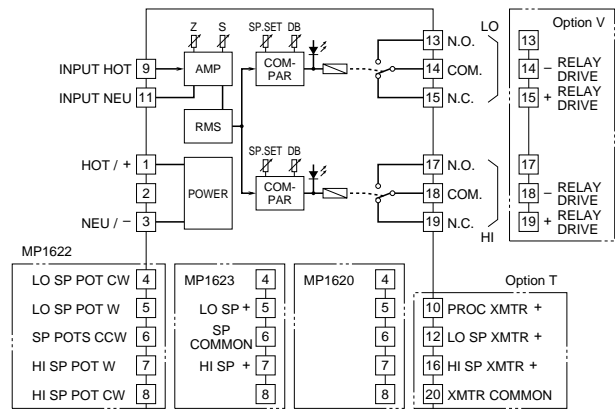

TERMINAL ASSIGNMENT

■SINGLE OUTPUT

PIN	MP1600	MP1600 w/Option T	MP1602	MP1602 w/Option T	MP1603	MP1603 w/Option T
1	POWER (Hot/+)	POWER (Hot/+)	POWER (Hot/+)	POWER (Hot/+)	POWER (Hot/+)	POWER (Hot/+)
2	No Connection	No Connection	No Connection	No Connection	No Connection	No Connection
3	POWER (Neu/-)	POWER (Neu/-)	POWER (Neu/-)	POWER (Neu/-)	POWER (Neu/-)	POWER (Neu/-)
4	INPUT (Hot)	No Connection	No Connection	No Connection	No Connection	No Connection
5	INPUT (Neu)	No Connection	SP Pot CCW	SP Pot CCW	SP -	SP -
6	N.O.	No Connection	SP Pot W	SP Pot W	SP +	SP +
7	COM *	No Connection	SP Pot CW	SP Pot CW	No Connection	No Connection
8	N.C. *	SP Xmtr +	No Connection	SP Xmtr +	No Connection	SP Xmtr +
9	N.O.	INPUT (Hot)	INPUT (Hot)	INPUT (Hot)	INPUT (Hot)	INPUT (Hot)
10	COM	Xmtr Common	No Connection	Xmtr Common	No Connection	Xmtr Common
11	N.C.	INPUT (Neu)	INPUT (Neu)	INPUT (Neu)	INPUT (Neu)	INPUT (Neu)
12		Proc Xmtr +	No Connection	Proc Xmtr +	No Connection	Proc Xmtr +
13		N.O.	N.O.	N.O.	N.O.	N.O.
14		COM *	COM *	COM *	COM *	COM *
15		N.C. *	N.C. *	N.C. *	N.C. *	N.C. *
16		No Connection	No Connection	No Connection	No Connection	No Connection
17		N.O.	N.O.	N.O.	N.O.	N.O.
18		COM	COM	COM	COM	COM
19		N.C.	N.C.	N.C.	N.C.	N.C.
20		No Connection	No Connection	No Connection	No Connection	No Connection

KEYS
 N.O. = Normally Open
 COM = Common
 N.C. = Normally Closed
 Proc = Process
 Xmtr = Transmitter
 SP = Setpoint
 W = Wiper
 CW = Clockwise
 CCW = Counterclockwise

***Pins used for Option V**
 20-pin = 14(+) - 15(-)
 11-pin = 7(+) - 8(-)

■LATCHING OUTPUT

PIN	MP1610	MP1610 w/Option T	MP1612	MP1612 w/Option T	MP1613	MP1613 w/Option T
1	POWER (Hot/+)	POWER (Hot/+)	POWER (Hot/+)	POWER (Hot/+)	POWER (Hot/+)	POWER (Hot/+)
2	No Connection	No Connection	No Connection	No Connection	No Connection	No Connection
3	POWER (Neu/-)	POWER (Neu/-)	POWER (Neu/-)	POWER (Neu/-)	POWER (Neu/-)	POWER (Neu/-)
4	No Connection	No Connection	No Connection	No Connection	No Connection	No Connection
5	No Connection	No Connection	SP Pot CCW	SP Pot CCW	SP -	SP -
6	No Connection	No Connection	SP Pot W	SP Pot W	SP +	SP +
7	No Connection	No Connection	SP Pot CW	SP Pot CW	No Connection	No Connection
8	No Connection	SP Xmtr +	No Connection	SP Xmtr +	No Connection	SP Xmtr +
9	INPUT (Hot)	INPUT (Hot)	INPUT (Hot)	INPUT (Hot)	INPUT (Hot)	INPUT (Hot)
10	No Connection	Xmtr Common	No Connection	Xmtr Common	No Connection	Xmtr Common
11	INPUT (Neu)	INPUT (Neu)	INPUT (Neu)	INPUT (Neu)	INPUT (Neu)	INPUT (Neu)
12	No Connection	Proc Xmtr +	No Connection	Proc Xmtr +	No Connection	Proc Xmtr +
13	N.O.	N.O.	N.O.	N.O.	N.O.	N.O.
14	COM *	COM *	COM *	COM *	COM *	COM *
15	N.C. *	N.C. *	N.C. *	N.C. *	N.C. *	N.C. *
16	Latch Reset	Latch Reset	Latch Reset	Latch Reset	Latch Reset	Latch Reset
17	N.O.	N.O.	N.O.	N.O.	N.O.	N.O.
18	COM	COM	COM	COM	COM	COM
19	N.C.	N.C.	N.C.	N.C.	N.C.	N.C.
20	Latch Reset	Latch Reset	Latch Reset	Latch Reset	Latch Reset	Latch Reset

KEYS
 N.O. = Normally Open
 COM = Common
 N.C. = Normally Closed
 Proc = Process
 Xmtr = Transmitter
 SP = Setpoint
 W = Wiper
 CW = Clockwise
 CCW = Counterclockwise

***Pins used for Option V**
 20-pin = 14(+) - 15(-)

■DUAL OUTPUT

PIN	MP1620	MP1620 w/Option T	MP1622	MP1622 w/Option T	MP1623	MP1623 w/Option T
1	POWER (Hot/+)	POWER (Hot/+)	POWER (Hot/+)	POWER (Hot/+)	POWER (Hot/+)	POWER (Hot/+)
2	No Connection	No Connection	No Connection	No Connection	No Connection	No Connection
3	POWER (Neu/-)	POWER (Neu/-)	POWER (Neu/-)	POWER (Neu/-)	POWER (Neu/-)	POWER (Neu/-)
4	INPUT (Hot)	No Connection	Lo SP Pot CW	Lo SP Pot CW	No Connection	No Connection
5	INPUT (Neu)	No Connection	Lo SP Pot W	Lo SP Pot W	Lo SP +	Lo SP +
6	N.O.	No Connection	SP Pots CCW	SP Pots CCW	SP Common	SP Common
7	COM *	Hi Set	Hi SP Pot W	Hi SP Pot W	Hi SP +	Hi SP +
8	N.C. *	No Connection	Hi SP Pot CW	Hi SP Pot CW	No Connection	No Connection
9	N.O.	INPUT (Hot)	INPUT (Hot)	INPUT (Hot)	INPUT (Hot)	INPUT (Hot)
10	COM *	Lo Set	Proc Xmtr +	Proc Xmtr +	No Connection	Proc Xmtr +
11	N.C. *	INPUT (Neu)	INPUT (Neu)	INPUT (Neu)	INPUT (Neu)	INPUT (Neu)
12		Lo SP Xmtr +	No Connection	Lo SP Xmtr +	No Connection	Lo SP Xmtr +
13		N.O.	N.O.	N.O.	N.O.	N.O.
14		COM *	Lo Set	COM *	Lo Set	COM *
15		N.C. *	Lo Set	N.C. *	Lo Set	N.C. *
16		Hi SP Xmtr +	No Connection	Hi SP Xmtr +	No Connection	Hi SP Xmtr +
17		N.O.	N.O.	N.O.	N.O.	N.O.
18		COM *	Hi Set	COM *	Hi Set	COM *
19		N.C. *	Hi Set	N.C. *	Hi Set	N.C. *
20		Xmtr Common	No Connection	Xmtr Common	No Connection	Xmtr Common

KEYS
 N.O. = Normally Open
 COM = Common
 N.C. = Normally Closed
 Proc = Process
 Xmtr = Transmitter
 SP = Setpoint
 W = Wiper
 CW = Clockwise
 CCW = Counterclockwise

***Pins used for Option V**
 20-pin:
 Hi Set = 19(+) - 18(-)
 Lo Set = 15(+) - 14(-)
 11-pin:
 Hi Set = 7(+) - 8(-)
 Lo Set = 10(+) - 11(-)

