

Limit Alarms M-PAC

THERMOCOUPLE INPUT LIMIT ALARM

MODEL MP1200-1223

MODEL & SUFFIX CODE SELECTION

MP12□□-□-□/□

- MODEL** _____
- INPUT TYPE** _____
- RELAY CONTACT OUTPUT** _____
- SETPOINT CONTROL** _____
- INPUT THERMOCOUPLE** _____
- | | |
|------------------------------------|--------------------------------------|
| Standard Span
(10mV≤EMF) | Narrow Span
(3mV≤EMF<10mV) |
| 1 : (PR) | 1L: (PR) |
| 2 : K (CA) | 2L: K (CA) |
| 3 : E (CRC) | 3L: E (CRC) |
| 4 : J (IC) | 4L: J (IC) |
| 5 : T (CC) | 5L: T (CC) |
| 6 : B (RH) | 6L: B (RH) |
| 7 : R | 7L: R |
| 8 : S | 8L: S |
| 0 : Specify | 0L: Specify |
- POWER INPUT** _____
- F : 120V AC
J : 240V AC
R : 24V DC
S : 12V DC
- OPTIONS** _____
- H : Latching operation for dual trip (122X only);
Reset at power off (5 seconds min.)
- R : Reversed relay sense
- T : Transmitter output (0 – 1V DC)
- V : Relay drive voltage output
- X : Lo-trip sense for single trip; Lo/Lo for dual trip
- Y : Hi/Hi-trip sense for dual trip (122X only)

ORDERING INFORMATION

- Specify code number and variables.
- Code number (e.g. MP1200-2-F/T/V)
 - Temperature range (e.g. 0 – 800°C)

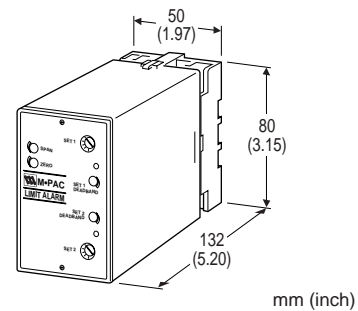

Functions & Features

- Accepting standard thermocouple inputs and providing relay contact closure(s) at a preset input level
- Cold junction compensation and upscale burnout protection as standard
- Downscale or no burnout optional
- Single, latching or dual setpoint
- Failsafe operation available
- Deadband adjustable from 1 to 100%
- Indicator LED provided

Typical Applications

- Annunciator
- Various alarm applications

GENERAL SPECIFICATIONS

- Construction:** plug-in
- Connection:** M3.5 screw terminals on base socket
- Housing material:** flame-resistant resin (black)
- Isolation:** input to output to power
(non-isolated between I/O with Option V)
- Zero/span adjustments:** ±5% (front)
- Setpoint adjustments:** front accessed three-turn screwdriver, remote dial potentiometer or DC input
- Deadband adjustments:** front accessed single-turn screwdriver; 1 – 100%
- Front LEDs:** red lights turn on at a tripped condition
- Burnout protection:** upscale standard; downscale or no burnout optional
- Cold junction compensation:** CJC sensor attached to the input terminals
- Power ON timer:** relays de-energized for approx. 2 seconds after power is turned on.



INPUT & OUTPUT

■**INPUT:** thermocouples
Span: standard span 10mV min., narrow span 3mV min.

Zero suppression/elevation: max. 1.5 times span

Input resistance: 10k Ω minimum

Burnout sensing: 0.1 μ A

Minimum span requirement*

T/C	STANDARD ($\geq 10\text{mV}$)		NARROW ($< 10\text{mV}$)	
	$^{\circ}\text{C}$	$^{\circ}\text{F}$	$^{\circ}\text{C}$	$^{\circ}\text{F}$
R	962	1751	361	665
S	1036	1883	373	686
K (CA)	247	445	74	135
E (CRC)	153	282	50	92
J (IC)	186	339	58	106
T (CC)	214	394	73	135
Others	Consult factory or representatives.			

*Approximate values to obtain minimum e.m.f. span for your reference. Consult thermocouple reference tables, factory or representatives for confirmation.

REMOTE SETPOINT INPUT

MP12X2: potentiometer; any value of 1k – 100k Ω ; excitation 4V

MP12X3: 0 – 1V DC

RELAY CONTACT OUTPUT

•**Single/Latching:** isolated DPDT relay; de-energized at trip

•**Dual:** isolated SPDT relay; energized at trip

Rating: 120V AC @3A ($\cos\phi=1$)
 30V DC @3A (resistive load)

Relay life

Electrical: 10^5 cycles

Mechanical: 10^7 cycles

For maximum relay life with inductive loads, external protection is recommended.

■**VOLTAGE OUTPUT (Option V):** 24V DC average;
 Drives 1.2k Ω or greater coil impedance

■**TRANSMITTER OUTPUT (Option T):** 0 – 1V DC;
 1mA max. (setpoint and process input)

INSTALLATION**Power input**

AC: rating $\pm 10\%$, 50/60 ± 2 Hz, approx. 2VA

DC: rating $\pm 10\%$ (ripple 10% p-p max.)
 80mA at 24V, 160mA at 12V

Operating temperature: -5 to +60 $^{\circ}\text{C}$ (23 to 140 $^{\circ}\text{F}$)

Storage temperature: -20 to +85 $^{\circ}\text{C}$ (-5 to +185 $^{\circ}\text{F}$)

Operating humidity: 30 to 90% RH (non-condensing)

Mounting: surface (DIN rail available for 11-pin base)

Dimensions

11-pin base: W50 \times H80 \times D132 mm
 (1.97" \times 3.15" \times 5.20")

See General Spec. Sheet Figure A.

20-pin base: W80 \times H101 \times D136 mm
 (3.15" \times 3.98" \times 5.35")

See General Spec. Sheet Figure B.

Weight: 400 g (0.88 lbs)

PERFORMANCE in percentage of span

Repeatability: $\pm 0.2\%$

Cold junction compensation error

(at 20 $^{\circ}\text{C}$ $\pm 10^{\circ}\text{C}$ or 68 $^{\circ}\text{F}$ $\pm 18^{\circ}\text{F}$)

K, E, J & T: $\pm 0.5^{\circ}\text{C}$ or $\pm 0.9^{\circ}\text{F}$ maximum

S, R & PR: $\pm 1^{\circ}\text{C}$ or $\pm 1.8^{\circ}\text{F}$ maximum

Temp. coefficient: $\pm 0.05\%/^{\circ}\text{C}$ ($\pm 0.027\%/^{\circ}\text{F}$)

Response time: 100 milliseconds, typical

Burnout response: 1 second

Common mode rejection

60 Hz: greater than 120 dB

DC: greater than 140 dB

Line voltage effect: $\pm 0.1\%$ over voltage range

Insulation resistance: $\geq 100\text{M}\Omega$ with 500V DC

Dielectric strength: 1000V AC @1 minute

(input to output to power)

2000V AC @1 minute (output to ground)



BLOCK DIAGRAM

■ SINGLE / LATCHING OUTPUT •11-pin Base

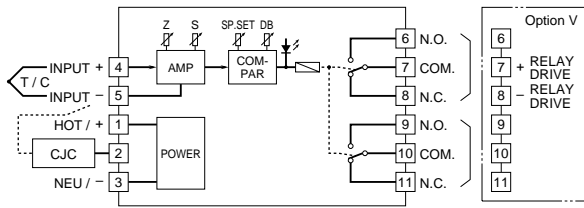

•20-pin Base

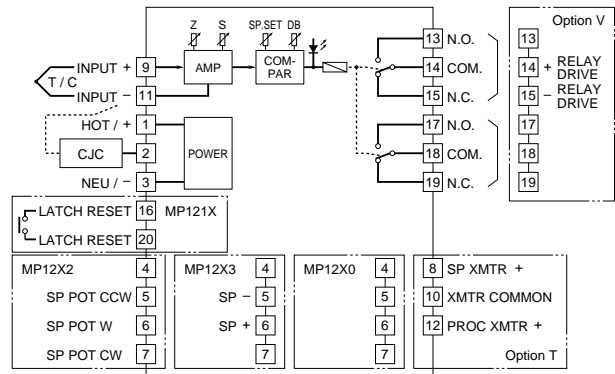

■ DUAL OUTPUT •11-pin Base

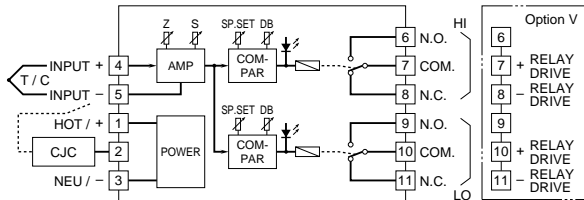

•20-pin Base

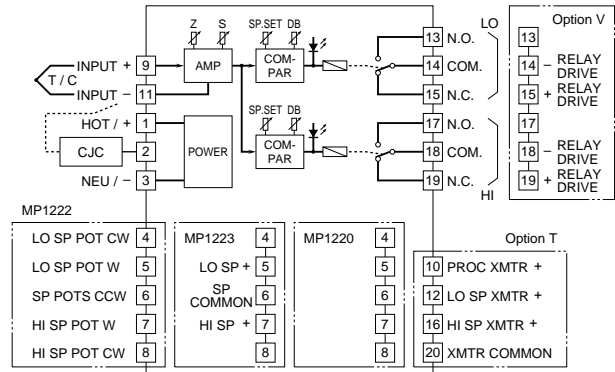

TERMINAL ASSIGNMENT

■SINGLE OUTPUT

PIN	MP1200	MP1200 w/Option T	MP1202	MP1202 w/Option T	MP1203	MP1203 w/Option T
1	POWER (Hot/+)	POWER (Hot/+)	POWER (Hot/+)	POWER (Hot/+)	POWER (Hot/+)	POWER (Hot/+)
2	CJC	CJC	CJC	CJC	CJC	CJC
3	POWER (Neu/-)	POWER (Neu/-)	POWER (Neu/-)	POWER (Neu/-)	POWER (Neu/-)	POWER (Neu/-)
4	INPUT +	No Connection	No Connection	No Connection	No Connection	No Connection
5	INPUT -	No Connection	SP Pot CCW	SP Pot CCW	SP -	SP -
6	N.O.	No Connection	SP Pot W	SP Pot W	SP +	SP +
7	COM *	No Connection	SP Pot CW	SP Pot CW	No Connection	No Connection
8	N.C. *	SP Xmtr +	No Connection	SP Xmtr +	No Connection	SP Xmtr +
9	N.O.	INPUT +	INPUT +	INPUT +	INPUT +	INPUT +
10	COM	Xmtr Common	No Connection	Xmtr Common	No Connection	Xmtr Common
11	N.C.	INPUT -	INPUT -	INPUT -	INPUT -	INPUT -
12		Proc Xmtr +	No Connection	Proc Xmtr +	No Connection	Proc Xmtr +
13		N.O.	N.O.	N.O.	N.O.	N.O.
14		COM *	COM *	COM *	COM *	COM *
15		N.C. *	N.C. *	N.C. *	N.C. *	N.C. *
16		No Connection	No Connection	No Connection	No Connection	No Connection
17		N.O.	N.O.	N.O.	N.O.	N.O.
18		COM	COM	COM	COM	COM
19		N.C.	N.C.	N.C.	N.C.	N.C.
20		No Connection	No Connection	No Connection	No Connection	No Connection

KEYS
 N.O. = Normally Open
 COM = Common
 N.C. = Normally Closed
 Proc = Process
 Xmtr = Transmitter
 SP = Setpoint
 W = Wiper
 CW = Clockwise
 CCW = Counterclockwise

***Pins used for Option V**
 20-pin = 14(+) - 15(-)
 11-pin = 7(+) - 8(-)

■LATCHING OUTPUT

PIN	MP1210	MP1210 w/Option T	MP1212	MP1212 w/Option T	MP1213	MP1213 w/Option T
1	POWER (Hot/+)	POWER (Hot/+)	POWER (Hot/+)	POWER (Hot/+)	POWER (Hot/+)	POWER (Hot/+)
2	CJC	CJC	CJC	CJC	CJC	CJC
3	POWER (Neu/-)	POWER (Neu/-)	POWER (Neu/-)	POWER (Neu/-)	POWER (Neu/-)	POWER (Neu/-)
4	No Connection	No Connection	No Connection	No Connection	No Connection	No Connection
5	No Connection	No Connection	SP Pot CCW	SP Pot CCW	SP -	SP -
6	No Connection	No Connection	SP Pot W	SP Pot W	SP +	SP +
7	No Connection	No Connection	SP Pot CW	SP Pot CW	No Connection	No Connection
8	No Connection	SP Xmtr +	No Connection	SP Xmtr +	No Connection	SP Xmtr +
9	INPUT +	INPUT +	INPUT +	INPUT +	INPUT +	INPUT +
10	No Connection	Xmtr Common	No Connection	Xmtr Common	No Connection	Xmtr Common
11	INPUT -	INPUT -	INPUT -	INPUT -	INPUT -	INPUT -
12	No Connection	Proc Xmtr +	No Connection	Proc Xmtr +	No Connection	Proc Xmtr +
13	N.O.	N.O.	N.O.	N.O.	N.O.	N.O.
14	COM *	COM *	COM *	COM *	COM *	COM *
15	N.C. *	N.C. *	N.C. *	N.C. *	N.C. *	N.C. *
16	Latch Reset	Latch Reset	Latch Reset	Latch Reset	Latch Reset	Latch Reset
17	N.O.	N.O.	N.O.	N.O.	N.O.	N.O.
18	COM	COM	COM	COM	COM	COM
19	N.C.	N.C.	N.C.	N.C.	N.C.	N.C.
20	Latch Reset	Latch Reset	Latch Reset	Latch Reset	Latch Reset	Latch Reset

KEYS
 N.O. = Normally Open
 COM = Common
 N.C. = Normally Closed
 Proc = Process
 Xmtr = Transmitter
 SP = Setpoint
 W = Wiper
 CW = Clockwise
 CCW = Counterclockwise

***Pins used for Option V**
 20-pin = 14(+) - 15(-)

■DUAL OUTPUT

PIN	MP1220	MP1220 w/Option T	MP1222	MP1222 w/Option T	MP1223	MP1223 w/Option T
1	POWER (Hot/+)	POWER (Hot/+)	POWER (Hot/+)	POWER (Hot/+)	POWER (Hot/+)	POWER (Hot/+)
2	CJC	CJC	CJC	CJC	CJC	CJC
3	POWER (Neu/-)	POWER (Neu/-)	POWER (Neu/-)	POWER (Neu/-)	POWER (Neu/-)	POWER (Neu/-)
4	INPUT +	No Connection	Lo SP Pot CW	Lo SP Pot CW	No Connection	No Connection
5	INPUT -	No Connection	Lo SP Pot W	Lo SP Pot W	Lo SP +	Lo SP +
6	N.O.	No Connection	SP Pots CCW	SP Pots CCW	SP Common	SP Common
7	COM *	Hi Set	Hi SP Pot W	Hi SP Pot W	Hi SP +	Hi SP +
8	N.C. *	No Connection	Hi SP Pot CW	Hi SP Pot CW	No Connection	No Connection
9	N.O.	INPUT +	INPUT +	INPUT +	INPUT +	INPUT +
10	COM *	Lo Set	Proc Xmtr +	Proc Xmtr +	No Connection	Proc Xmtr +
11	N.C. *	INPUT -	INPUT -	INPUT -	INPUT -	INPUT -
12		Lo SP Xmtr +	No Connection	Lo SP Xmtr +	No Connection	Lo SP Xmtr +
13		N.O.	N.O.	N.O.	N.O.	N.O.
14		COM *	Lo Set	COM *	Lo Set	COM *
15		N.C. *	Lo Set	N.C. *	Lo Set	N.C. *
16		Hi SP Xmtr +	No Connection	Hi SP Xmtr +	No Connection	Hi SP Xmtr +
17		N.O.	N.O.	N.O.	N.O.	N.O.
18		COM *	Hi Set	COM *	Hi Set	COM *
19		N.C. *	Hi Set	N.C. *	Hi Set	N.C. *
20		Xmtr Common	No Connection	Xmtr Common	No Connection	Xmtr Common

KEYS
 N.O. = Normally Open
 COM = Common
 N.C. = Normally Closed
 Proc = Process
 Xmtr = Transmitter
 SP = Setpoint
 W = Wiper
 CW = Clockwise
 CCW = Counterclockwise

***Pins used for Option V**
 20-pin:
 Hi Set = 19(+) - 18(-)
 Lo Set = 15(+) - 14(-)
 11-pin:
 Hi Set = 7(+) - 8(-)
 Lo Set = 10(+) - 11(-)

