

**Limit Alarms M-PAC**

**DC INPUT LIMIT ALARM**

**MODEL MP1000-1023**

**MODEL & SUFFIX CODE SELECTION**

MP10□□-□□□□

- MODEL** \_\_\_\_\_
- INPUT TYPE** \_\_\_\_\_
- 0** : DC current or voltage
- RELAY CONTACT OUTPUT** \_\_\_\_\_
- 0** : Single (Hi) trip, non-latching
- 1** : Single (Hi) trip, latching
- 2** : Dual (Hi/Lo) trip, non-latching
- SETPOINT CONTROL** \_\_\_\_\_
- 0** : Front-accessed three-turn screwdriver adjust.
- 2** : Remote dial connections (total resistance 1k – 100kΩ)
- 3** : DC programmable (0 – 1V)
- INPUT RANGE** \_\_\_\_\_
- | Current                    | Voltage  |
|----------------------------|--|
| <b>A</b> : 4 – 20mA DC     | <b>1</b> : 0 – 10mV DC                         |
| <b>B</b> : 2 – 10mA DC     | <b>2</b> : 0 – 100mV DC                        |
| <b>C</b> : 1 – 5mA DC      | <b>3</b> : 0 – 1V DC                           |
| <b>D</b> : 0 – 20mA DC     | <b>4</b> : 0 – 10V DC                          |
| <b>E</b> : 0 – 16mA DC     | <b>5</b> : 0 – 5V DC                           |
| <b>F</b> : 0 – 10mA DC     | <b>6</b> : 1 – 5V DC                           |
| <b>G</b> : 0 – 1mA DC      | <b>U1</b> : Specify voltage<br>(10≤span<100mV) |
| <b>H</b> : 10 – 50mA DC    | <b>U2</b> : Specify voltage<br>(0.1≤span<1V)   |
| <b>Z</b> : Specify current | <b>U3</b> : Specify voltage<br>(1V≤span)       |
- POWER INPUT** \_\_\_\_\_
- F** : 120V AC
- J** : 240V AC
- R** : 24V DC
- S** : 12V DC
- OPTIONS** \_\_\_\_\_
- H** : Latching operation for dual trip (102X only);  
Reset at power off (5 seconds min.)
- R** : Reversed relay sense
- T** : Transmitter output (0 – 1V DC)
- V** : Relay drive voltage output
- X** : Lo-trip sense for single trip; Lo/Lo for dual trip
- Y** : Hi/Hi-trip sense for dual trip (102X only)

**ORDERING INFORMATION**

- Specify code number and variables.
- **Code number** (e.g. MP1000-6-F/T/V)
  - **Special input range** (For codes Z, U1, U2 & U3)

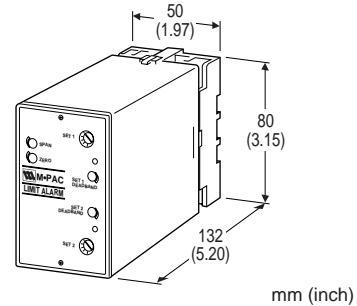

**Functions & Features**

- Accepting a large variety of DC inputs and providing relay contact closure(s) at a preset input level
- Single, latching or dual setpoint • Failsafe operation available • Deadband adjustable from 1 to 100%
- Indicator LED provided

**Typical Applications**

- Annunciator • Various alarm applications

**GENERAL SPECIFICATIONS**

- Construction:** plug-in
- Connection:** M3.5 screw terminals on base socket
- Housing material:** flame-resistant resin (black)
- Isolation:** input to output to power  
(non-isolated between I/O with Option V)
- Zero/span adjustments:** ±5% (front)
- Setpoint adjustments:** front accessed three-turn screwdriver, remote dial potentiometer or DC input
- Deadband adjustments:** front accessed single-turn screwdriver; 1 – 100%
- Front LEDs:** red lights turn on at a tripped condition
- Power ON timer:** relays de-energized for approx. 2 seconds after power is turned on.

**INPUT & OUTPUT****INPUT**

• **DC Current:** input resistor incorporated

**Input resistance:** For resistance values other than listed below, specify when ordering.

Input	Input Resistance
4 – 20mA	: 250 (Ω)
2 – 10mA	: 500
1 – 5mA	: 1000
0 – 20mA	: 50
0 – 16mA	: 62.5
0 – 10mA	: 100
0 – 1mA	: 1000
10 – 50mA	: 100

• **DC Voltage:** -300 – +300V DC

**Minimum span:** 10mV

**Zero suppression/elevation:** max. 1.5 times span

**Input resistance**

Input Span	Input Resistance
10 – 100mV	: 10k (Ω minimum)
0.1 – 1V	: 100k
≥1V	: 1M

**REMOTE SETPOINT INPUT**

**MP10X2:** potentiometer; any value of 1k – 100kΩ; excitation 4V

**MP10X3:** 0 – 1V DC

**RELAY CONTACT OUTPUT**

• **Single/Latching:** isolated DPDT relay; de-energized at trip

• **Dual:** isolated SPDT relay; energized at trip

**Rating:** 120V AC @3A ( $\cos\phi=1$ )  
30V DC @3A (resistive load)

**Relay life**

**Electrical:**  $10^5$  cycles

**Mechanical:**  $10^7$  cycles

For maximum relay life with inductive loads, external protection is recommended.

■ **VOLTAGE OUTPUT (Option V):** 24V DC average;  
Drives 1.2kΩ or greater coil impedance

■ **TRANSMITTER OUTPUT (Option T):** 0 – 1V DC;  
1mA max. (setpoint and process input)

**INSTALLATION****Power input**

**AC:** rating  $\pm 10\%$ , 50/60  $\pm 2$  Hz, approx. 2VA

**DC:** rating  $\pm 10\%$  (ripple 10% p-p max.)  
80mA at 24V, 160mA at 12V

**Operating temperature:** -5 to +60°C (23 to 140°F)

**Storage temperature:** -20 to +85°C (-5 to +185°F)

**Operating humidity:** 30 to 90% RH (non-condensing)

**Mounting:** surface (DIN rail available for 11-pin base)

**Dimensions**

**11-pin base:** W50×H80×D132 mm  
(1.97"×3.15"×5.20")

See General Spec. Sheet Figure A.

**20-pin base:** W80×H101×D136 mm  
(3.15"×3.98"×5.35")

See General Spec. Sheet Figure B.

**Weight:** 400 g (0.88 lbs)

**PERFORMANCE in percentage of span**

**Repeatability:**  $\pm 0.2\%$

**Temp. coefficient:**  $\pm 0.05\%/^{\circ}\text{C}$  ( $\pm 0.027\%/^{\circ}\text{F}$ )

**Response time:** 100 milliseconds, typical

**Common mode rejection**

**60 Hz:** greater than 120 dB

**DC:** greater than 140 dB

**Line voltage effect:**  $\pm 0.1\%$  over voltage range

**Insulation resistance:**  $\geq 100\text{M}\Omega$  with 500V DC

**Dielectric strength:** 1000V AC @1 minute

(input to output to power)

2000V AC @1 minute (output to ground)



# BLOCK DIAGRAM

## ■ SINGLE / LATCHING OUTPUT

### •11-pin Base

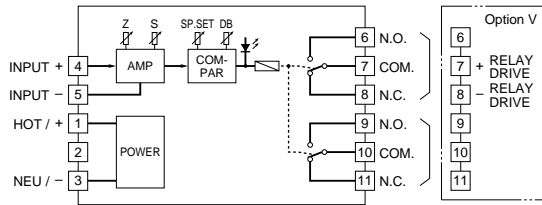

### •20-pin Base

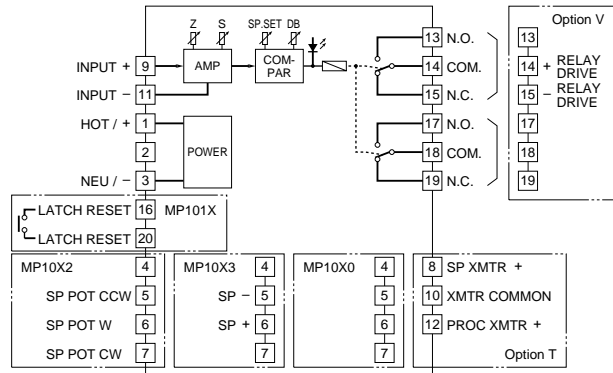

## ■ DUAL OUTPUT

### •11-pin Base

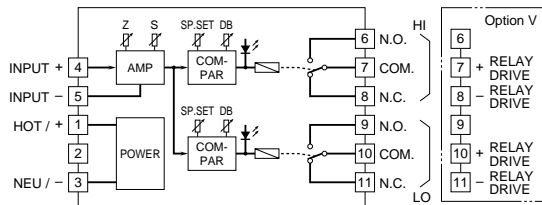

### •20-pin Base

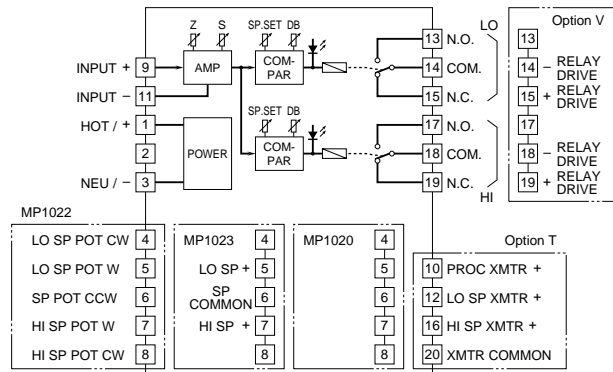

**TERMINAL ASSIGNMENT**

**■SINGLE OUTPUT**

PIN	MP1000	MP1000 w/Option T	MP1002	MP1002 w/Option T	MP1003	MP1003 w/Option T
1	POWER (Hot/+)	POWER (Hot/+)	POWER (Hot/+)	POWER (Hot/+)	POWER (Hot/+)	POWER (Hot/+)
2	No Connection	No Connection	No Connection	No Connection	No Connection	No Connection
3	POWER (Neu/-)	POWER (Neu/-)	POWER (Neu/-)	POWER (Neu/-)	POWER (Neu/-)	POWER (Neu/-)
4	INPUT +	No Connection	No Connection	No Connection	No Connection	No Connection
5	INPUT -	No Connection	SP Pot CCW	SP Pot CCW	SP -	SP -
6	N.O.	No Connection	SP Pot W	SP Pot W	SP +	SP +
7	COM *	No Connection	SP Pot CW	SP Pot CW	No Connection	No Connection
8	N.C. *	SP Xmtr +	No Connection	SP Xmtr +	No Connection	SP Xmtr +
9	N.O.	INPUT +	INPUT +	INPUT +	INPUT +	INPUT +
10	COM	Xmtr Common	No Connection	Xmtr Common	No Connection	Xmtr Common
11	N.C.	INPUT -	INPUT -	INPUT -	INPUT -	INPUT -
12		Proc Xmtr +	No Connection	Proc Xmtr +	No Connection	Proc Xmtr +
13		N.O.	N.O.	N.O.	N.O.	N.O.
14		COM *	COM *	COM *	COM *	COM *
15		N.C. *	N.C. *	N.C. *	N.C. *	N.C. *
16		No Connection	No Connection	No Connection	No Connection	No Connection
17		N.O.	N.O.	N.O.	N.O.	N.O.
18		COM	COM	COM	COM	COM
19		N.C.	N.C.	N.C.	N.C.	N.C.
20		No Connection	No Connection	No Connection	No Connection	No Connection

**KEYS**  
 N.O. = Normally Open  
 COM = Common  
 N.C. = Normally Closed  
 Proc = Process  
 Xmtr = Transmitter  
 SP = Setpoint  
 W = Wiper  
 CW = Clockwise  
 CCW = Counterclockwise

**\*Pins used for Option V**  
 20-pin = 14(+) - 15(-)  
 11-pin = 7(+) - 8(-)

**■LATCHING OUTPUT**

PIN	MP1010	MP1010 w/Option T	MP1012	MP1012 w/Option T	MP1013	MP1013 w/Option T
1	POWER (Hot/+)	POWER (Hot/+)	POWER (Hot/+)	POWER (Hot/+)	POWER (Hot/+)	POWER (Hot/+)
2	No Connection	No Connection	No Connection	No Connection	No Connection	No Connection
3	POWER (Neu/-)	POWER (Neu/-)	POWER (Neu/-)	POWER (Neu/-)	POWER (Neu/-)	POWER (Neu/-)
4	No Connection	No Connection	No Connection	No Connection	No Connection	No Connection
5	No Connection	No Connection	SP Pot CCW	SP Pot CCW	SP -	SP -
6	No Connection	No Connection	SP Pot W	SP Pot W	SP +	SP +
7	No Connection	No Connection	SP Pot CW	SP Pot CW	No Connection	No Connection
8	No Connection	SP Xmtr +	No Connection	SP Xmtr +	No Connection	SP Xmtr +
9	INPUT +	INPUT +	INPUT +	INPUT +	INPUT +	INPUT +
10	No Connection	Xmtr Common	No Connection	Xmtr Common	No Connection	Xmtr Common
11	INPUT -	INPUT -	INPUT -	INPUT -	INPUT -	INPUT -
12	No Connection	Proc Xmtr +	No Connection	Proc Xmtr +	No Connection	Proc Xmtr +
13	N.O.	N.O.	N.O.	N.O.	N.O.	N.O.
14	COM *	COM *	COM *	COM *	COM *	COM *
15	N.C. *	N.C. *	N.C. *	N.C. *	N.C. *	N.C. *
16	Latch Reset	Latch Reset	Latch Reset	Latch Reset	Latch Reset	Latch Reset
17	N.O.	N.O.	N.O.	N.O.	N.O.	N.O.
18	COM	COM	COM	COM	COM	COM
19	N.C.	N.C.	N.C.	N.C.	N.C.	N.C.
20	Latch Reset	Latch Reset	Latch Reset	Latch Reset	Latch Reset	Latch Reset

**KEYS**  
 N.O. = Normally Open  
 COM = Common  
 N.C. = Normally Closed  
 Proc = Process  
 Xmtr = Transmitter  
 SP = Setpoint  
 W = Wiper  
 CW = Clockwise  
 CCW = Counterclockwise

**\*Pins used for Option V**  
 20-pin = 14(+) - 15(-)

**■DUAL OUTPUT**

PIN	MP1020	MP1020 w/Option T	MP1022	MP1022 w/Option T	MP1023	MP1023 w/Option T
1	POWER (Hot/+)	POWER (Hot/+)	POWER (Hot/+)	POWER (Hot/+)	POWER (Hot/+)	POWER (Hot/+)
2	No Connection	No Connection	No Connection	No Connection	No Connection	No Connection
3	POWER (Neu/-)	POWER (Neu/-)	POWER (Neu/-)	POWER (Neu/-)	POWER (Neu/-)	POWER (Neu/-)
4	INPUT +	No Connection	Lo SP Pot CW	Lo SP Pot CW	No Connection	No Connection
5	INPUT -	No Connection	Lo SP Pot W	Lo SP Pot W	Lo SP +	Lo SP +
6	N.O.	No Connection	SP Pots CCW	SP Pots CCW	SP Common	SP Common
7	COM *	Hi Set	Hi SP Pot W	Hi SP Pot W	Hi SP +	Hi SP +
8	N.C. *	No Connection	Hi SP Pot CW	Hi SP Pot CW	No Connection	No Connection
9	N.O.	INPUT +	INPUT +	INPUT +	INPUT +	INPUT +
10	COM *	Lo Set	Proc Xmtr +	Proc Xmtr +	No Connection	Proc Xmtr +
11	N.C. *	INPUT -	INPUT -	INPUT -	INPUT -	INPUT -
12		Lo SP Xmtr +	No Connection	Lo SP Xmtr +	No Connection	Lo SP Xmtr +
13		N.O.	N.O.	N.O.	N.O.	N.O.
14		COM *	Lo Set	COM *	Lo Set	COM *
15		N.C. *	Lo Set	N.C. *	Lo Set	N.C. *
16		Hi SP Xmtr +	No Connection	Hi SP Xmtr +	No Connection	Hi SP Xmtr +
17		N.O.	N.O.	N.O.	N.O.	N.O.
18		COM *	Hi Set	COM *	Hi Set	COM *
19		N.C. *	Hi Set	N.C. *	Hi Set	N.C. *
20		Xmtr Common	No Connection	Xmtr Common	No Connection	Xmtr Common

**KEYS**  
 N.O. = Normally Open  
 COM = Common  
 N.C. = Normally Closed  
 Proc = Process  
 Xmtr = Transmitter  
 SP = Setpoint  
 W = Wiper  
 CW = Clockwise  
 CCW = Counterclockwise

**\*Pins used for Option V**  
 20-pin:  
 Hi Set = 19(+) - 18(-)  
 Lo Set = 15(+) - 14(-)  
 11-pin:  
 Hi Set = 7(+) - 8(-)  
 Lo Set = 10(+) - 11(-)

