

Final Control Elements

VALVE POSITIONER

(for AC 24 V motor)

Functions & Features

- Solid-state valve positioner
- Direct drive of 24 V AC motor
- Split control
- Direct or reverse action
- Output circuit designed with no mechanical contact ensures long lasting reliability
- Feedback potentiometer 100 Ω - 10 kΩ

Typical Applications

- Proportional position control for electric valves or dampers in air conditioning systems

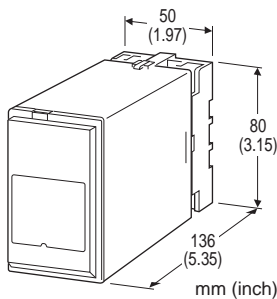

MODEL: MP-[1]-[2]

ORDERING INFORMATION

- Code number: MP-[1]-[2]
- Specify a code from below for each [1], [2]. (e.g. MP-1-B)

[1] I/O CHARACTERISTICS

Current

- 1: 4 - 20 mA DC (Input resistance 62.5 Ω)
- 2: 4 - 20 mA DC (Input resistance 62.5 Ω)
- 3: 4 - 12 mA DC (Input resistance 62.5 Ω)
- 4: 12 - 20 mA DC (Input resistance 62.5 Ω)

See the graph on the General Specification section.

FEEDBACK RESISTANCE

Total resistance 100 Ω - 10 kΩ

OUTPUT

24 V AC switch

[2] POWER INPUT

AC Power

- B: 100 V AC
- C: 110 V AC
- D: 115 V AC
- F: 120 V AC
- G: 200 V AC
- H: 220 V AC
- J: 240 V AC

GENERAL SPECIFICATIONS

Construction: Plug-in

Connection: M3.5 screw terminals

Housing material: Flame-resistant resin (black)

Sensitivity adjustment: 0 - 20 % of total feedback resistance at 0 % side; 70 - 100 % at 100 % side (front)

Deadband adjustment: 2 - 20 % (front)

Isolation: Input to output to power

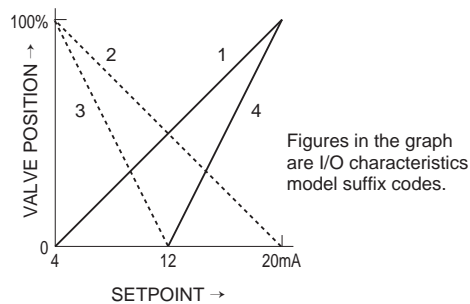

INPUT SPECIFICATIONS

- **Setpoint Signal**
- Input resistance:** Input resistor incorporated
- **Feedback Potentiometer:** 100 Ω - 10 kΩ
- Minimum span:** 50 % of total resistance
- Excitation:** 0.5 V DC

OUTPUT SPECIFICATIONS

Rated load: 24 V AC @ 1 A max.

Voltage drop: 6 V @ 1 A

(OFF duration must be longer than ON duration. ON duration at the maximum of 15 minutes.)

- **Output Operation** (terminal No. in parentheses)

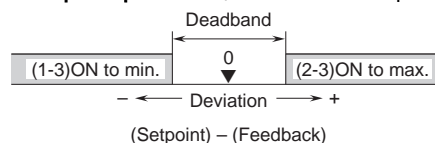

INSTALLATION

Power input

- **AC:** Operational voltage range: rating ± 10 %



50/60 \pm 2 Hz, approx. 2 VA

Operating temperature: -5 to +60°C (23 to 140°F)

Operating humidity: 30 to 90 %RH (non-condensing)

Mounting: Surface or DIN rail

Weight: 300 g (0.66 lbs)

PERFORMANCE in percentage of span

Accuracy: \pm 0.3 %

Insulation resistance: \geq 100 M Ω with 500 V DC

Dielectric strength: 1000 V AC @1 minute

(input to output to power)

2000 V AC @1 minute

(input or output or power to ground)

EXTERNAL VIEW

■MP-1, -2

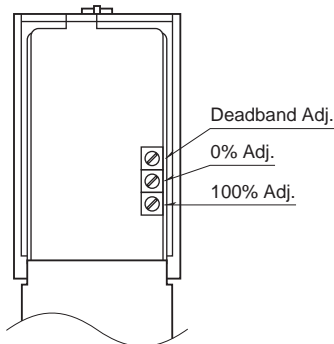

■MP-3, -4

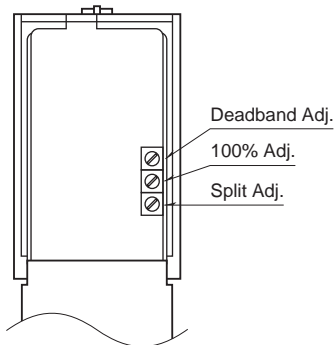

EXTERNAL DIMENSIONS & TERMINAL ASSIGNMENTS unit: mm (inch)

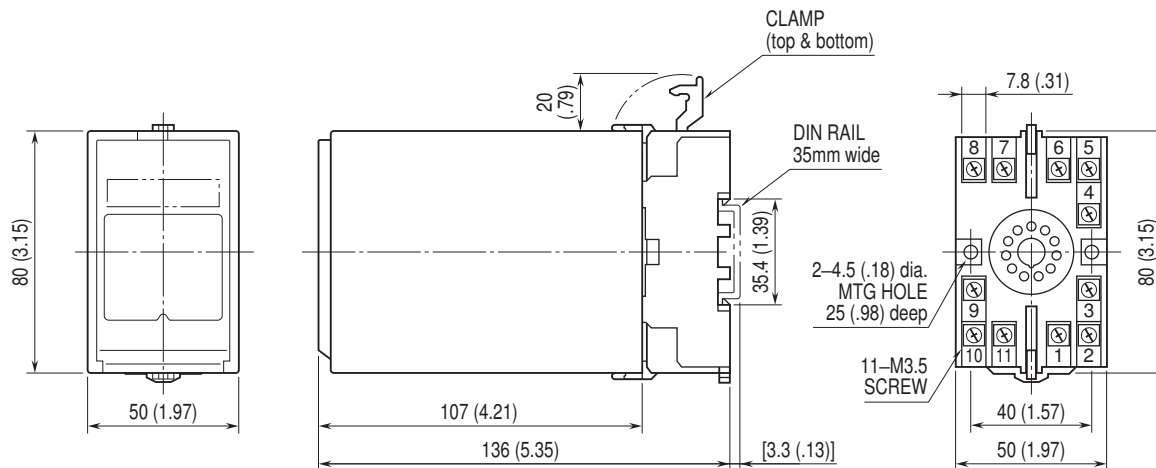

• When mounting, no extra space is needed between units.

SCHEMATIC CIRCUITRY & CONNECTION DIAGRAM

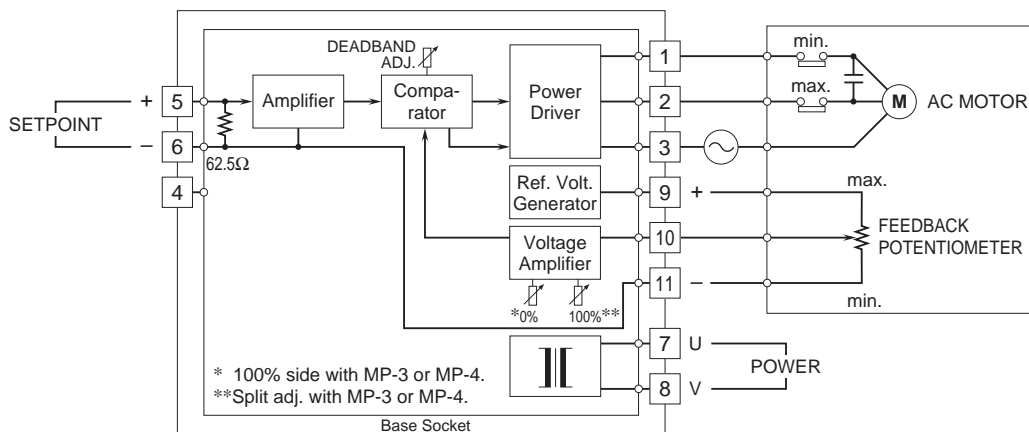

TERMINOLOGY

• Split Control

Control in which two or more output signals are generated according to different functions by one input signal.

[Example] Control of two valves in different actions in order to keep temperature steady: one for cold water and another for hot water.

Use a reverse acting Model MP-2 (-3) for hot water, and a direct acting Model MP-1 (-4) for cold water. When setpoint signal increases, the hot water valve is actuated to open, while the cold water valve is actuated to close. When setpoint signal decreases, the two valves move to opposite directions.

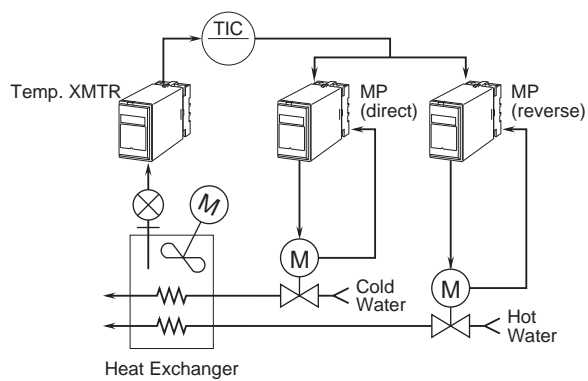

Specifications are subject to change without notice.

