

Plug-in Signal Conditioners M-UNIT

SPLIT-RANGE TRANSMITTER

(isolated four outputs)

Functions & Features

- Generates four isolated signals which could control multiple final control elements
- PC programmable
- High-density mounting

Typical Applications

- Manipulating multiple valves for split-range control

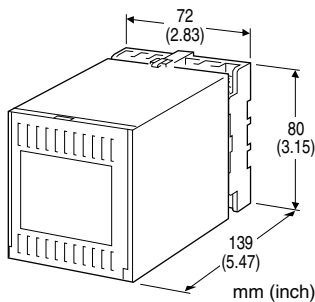

MODEL: MFS2-[1][2]-[3][4]

ORDERING INFORMATION

- Code number: MFS2-[1][2]-[3][4]
Specify a code from below for each [1] through [4].
(e.g. MFS2-A4-M/Q)
- Use Ordering Information Sheet (No. ESU-1383)
- Factory default setting (See "OPERATION DIAGRAM") will be used if not otherwise specified.
- Specify the specification for option code /Q
(e.g. /C01/S01)

[1] INPUT

Current

A: 4 - 20 mA DC (Input resistance 250 Ω)

Voltage

4: 0 - 10 V DC (Input resistance 1 MΩ min.)

6: 1 - 5 V DC (Input resistance 1 MΩ min.)

[2] OUTPUT 1 through 4

Current

A: 4 - 20 mA DC (Load resistance 500 Ω max.)

Voltage

4: 0 - 10 V DC (Load resistance 10 kΩ min.)

6: 1 - 5 V DC (Load resistance 5000 Ω min.)

[3] POWER INPUT

AC Power

M: 85 - 264 V AC (Operational voltage range 85 - 264 V, 47 - 66 Hz)

DC Power

R: 24 V DC

(Operational voltage range 24 V ±10 %, ripple 10 %p-p max.)

P: 110 V DC

(Operational voltage range 85 - 150 V, ripple 10 %p-p max.)

[4] OPTIONS

blank: none

/Q: With options (specify the specification)

SPECIFICATIONS OF OPTION: Q (multiple selections)

COATING (For the detail, refer to M-System's web site.)

/C01: Silicone coating

/C02: Polyurethane coating

/C03: Rubber coating

TERMINAL SCREW MATERIAL

/S01: Stainless steel

RELATED PRODUCTS

- PC configurator software (model: MFS2CFG)

Software downloadable at M-System's web site.

A dedicated cable is required to connect the module to the PC. Please refer to the internet software download site or the users manual for the PC configurator for applicable cable types.

GENERAL SPECIFICATIONS

Construction: Plug-in

Connection: M3.5 screw terminals

Screw terminal: Chromated steel (standard) or stainless steel

Housing material: Flame-resistant resin (black)

Isolation: Input to output 1 to output 2 to output 3 to output 4 to power

Overrange output: 0 to 100 %

Zero adjustment: -5 to +5 % (PC programming)

Span adjustment: 95 to 105 % (PC programming)

Power LED: Green light turns on in normal operating conditions.

Programming: Downloaded from PC; I/O characteristics, high/low limits, fixed output, etc.

Configurator connection: 2.5 dia. miniature jack; RS-232-C level

Fixed output: Preset fixed outputs provided by contact signal control at the terminals 5 - 6 (Open or Close trigger conditions can be programmed.)



INPUT SPECIFICATIONS

■ DC Current:

Shunt resistor attached to the input terminals (0.5 W)

■ Contact Input

Detecting voltage/current: 5 V DC / 50 μ A

Detection levels

ON resistance: $\leq 200 \Omega$, ≤ 0.5 V

OFF resistance: ≥ 100 k Ω , ≥ 3 V

INSTALLATION

Power consumption

•AC:

approx. 3 VA at 100 V

approx. 3.5 VA at 200 V

approx. 4 VA at 264 V

•DC: Approx. 2 W

Operating temperature: 0 to 50°C (32 to 122°F)

Operating humidity: 30 to 90 %RH (non-condensing)

Mounting: Surface or DIN rail

Weight: 400 g (0.88 lb)

PERFORMANCE in percentage of span

Accuracy: ± 0.5 %

Temp. coefficient: ± 0.05 %/°C (± 0.03 %/°F)

Response time: ≤ 0.5 sec. (0 - 90 %)

Line voltage effect: ± 0.5 % over voltage range

Insulation resistance: ≥ 100 M Ω with 500 V DC

Dielectric strength: 2000 V AC @ 1 minute

(input to output 1 or output 2 or output 3 or output 4 to power to ground)

500 V AC @ 1 minute (between each output)

EXTERNAL VIEW

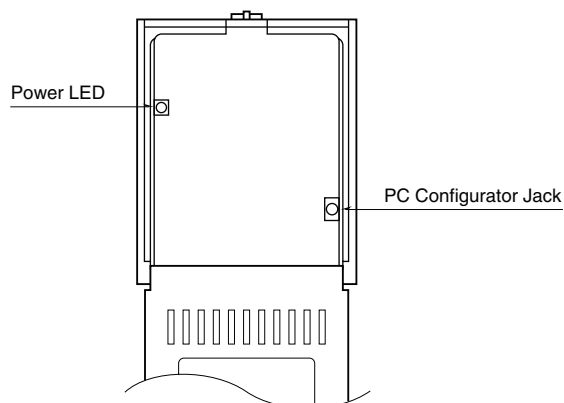

EXTERNAL DIMENSIONS & TERMINAL ASSIGNMENTS unit: mm (inch)

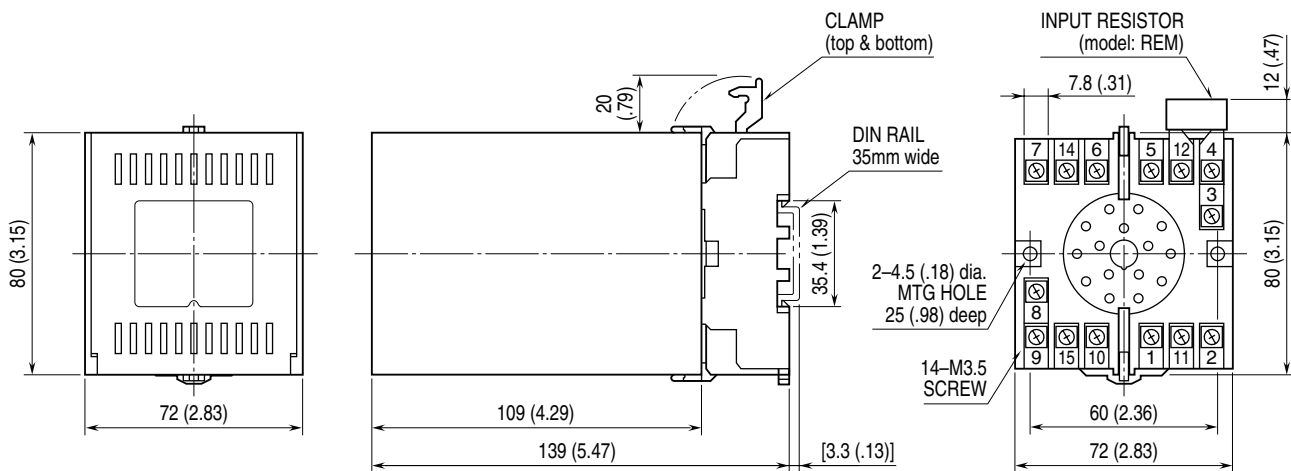

- When mounting, no extra space is needed between units.
- Input shunt resistor attached for current input.

SCHEMATIC CIRCUITRY & CONNECTION DIAGRAM

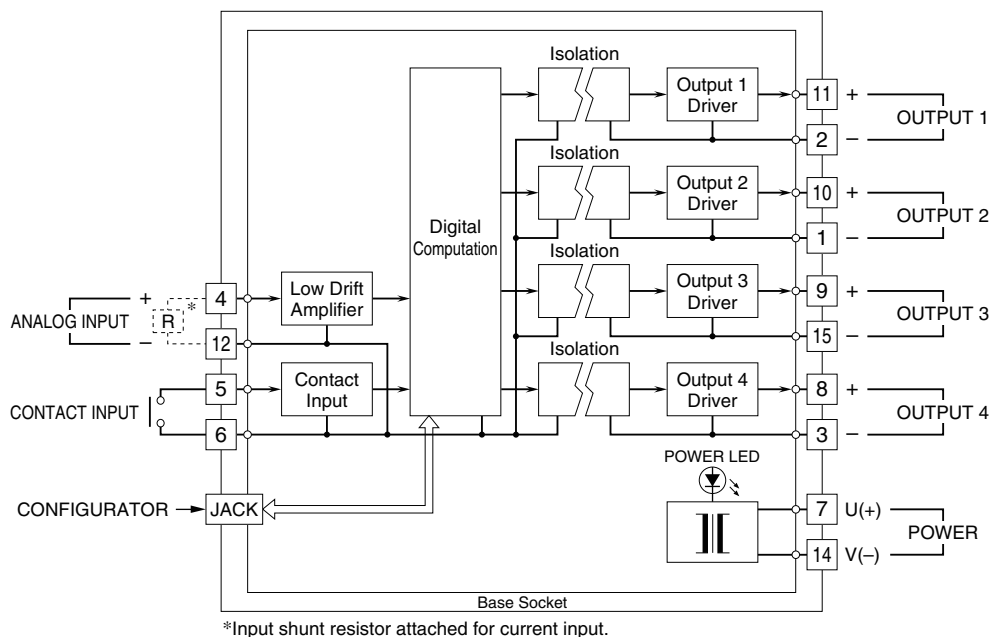

OPERATION DIAGRAM

The diagram below shows an example of I/O characteristics as specified in Table 1.

The split-range operations can be specified when ordering, by using Ordering Information Sheet, or programmed by the user using PC Configurator Software. Please refer to Users Manual for the PC Configurator for more information.

- 1) Two pairs of analog input and output in % define each split I/O range. Proportional (positive) or inverted (negative) characteristics can be specified.
- 2) High and low limits for each output can be specified independently within the full-scale range.
- 3) Fixed output value for each output can be specified independently in advance. These outputs are provided when the contact input is closed or opened (predefined).
H limit \geq Fixed output \geq Low limit
- 4) Applying the fixed output or not can be specified independently for each output.



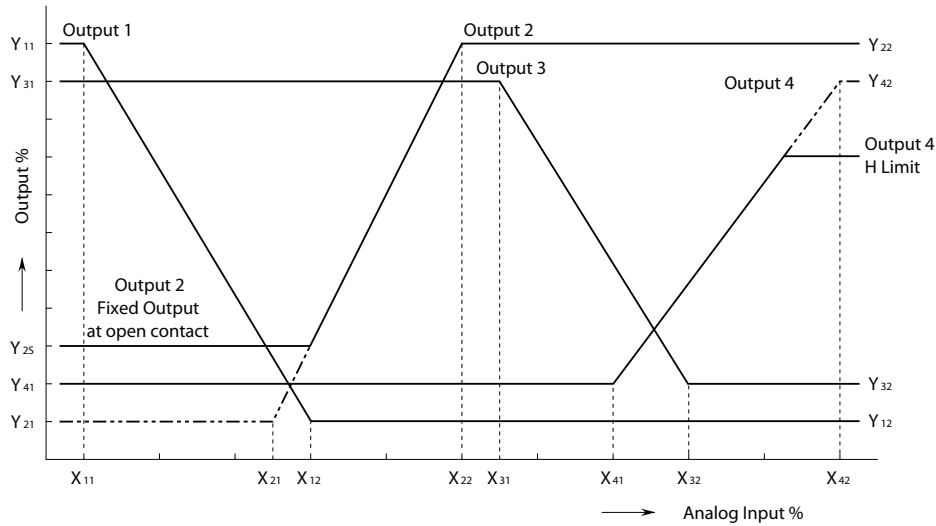

Table 1

| | INPUT % | OUTPUT % | LIMIT % | FIXED OUTPUT % | CONTACT INPUT | TRIGGER CONDITION |
|----------|---|--|--|-------------------------|---------------|-------------------|
| Output 1 | X ₁₁ = 0.00 X ₁₂ = 30.00 | Y ₁₁ = 100.00 Y ₁₂ = 0.00 | H ₁ = 100.00 L ₁ = 0.00 | Y _{1S} = 0.00 | Not applied | ---- |
| Output 2 | X ₂₁ = 25.00 X ₂₂ = 50.00 | Y ₂₁ = 0.00 Y ₂₂ = 100.00 | H ₂ = 100.00 L ₂ = 0.00 | Y _{2S} = 30.00 | Applied | Open |
| Output 3 | X ₃₁ = 55.00 X ₃₂ = 80.00 | Y ₃₁ = 90.00 Y ₃₂ = 10.00 | H ₃ = 90.00 L ₃ = 10.00 | Y _{3S} = 0.00 | Not applied | ---- |
| Output 4 | X ₄₁ = 70.00 X ₄₂ = 100.00 | Y ₄₁ = 10.00 Y ₄₂ = 90.00 | H ₄ = 70.00 L ₄ = 10.00 | Y _{4S} = 0.00 | Not applied | ---- |

Factory default setting used if no Ordering Information is provided:

| | INPUT % | OUTPUT % | LIMIT % | FIXED OUTPUT % | CONTACT INPUT | TRIGGER CONDITION |
|----------|--|--|--|------------------------|---------------|-------------------|
| Output 1 | X ₁₁ = 0.00 X ₁₂ = 100.00 | Y ₁₁ = 0.00 Y ₁₂ = 100.00 | H ₁ = 100.00 L ₁ = 0.00 | Y _{1S} = 0.00 | Not applied | Open |
| Output 2 | X ₂₁ = 0.00 X ₂₂ = 100.00 | Y ₂₁ = 0.00 Y ₂₂ = 100.00 | H ₂ = 100.00 L ₂ = 0.00 | Y _{2S} = 0.00 | Not applied | Open |
| Output 3 | X ₃₁ = 0.00 X ₃₂ = 100.00 | Y ₃₁ = 0.00 Y ₃₂ = 100.00 | H ₃ = 100.00 L ₃ = 0.00 | Y _{3S} = 0.00 | Not applied | Open |
| Output 4 | X ₄₁ = 0.00 X ₄₂ = 100.00 | Y ₄₁ = 0.00 Y ₄₂ = 100.00 | H ₄ = 100.00 L ₄ = 0.00 | Y _{4S} = 0.00 | Not applied | Open |



Specifications are subject to change without notice.

