

Final Control Elements

VALVE POSITIONER

(position-preset contact input ; built-in SSR)

Functions & Features

- Used for 24 - 200 V AC electric actuator position control
- Controls the electric actuator to a pre-configured target position based on contact input
- Position feedback via potentiometer (100 Ω - 10 kΩ unadjusted)
- Direct motor driving with built-in SSR (with zero-cross circuit)
- Restart control timer built-in to prevent motor overheating due to frequent on/off switching

Typical Applications

- Position damper control using sequencers without analog output

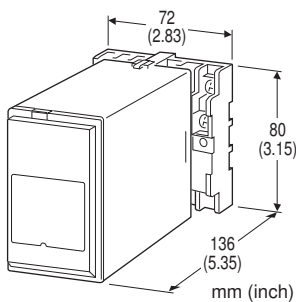

MODEL: MEX-P-[1][2]

ORDERING INFORMATION

- **Code number:** MEX-P-[1][2]

Specify a code from below for each [1] and [2].

(e.g. MEX-P-G/B/Q)

- Specify the specification for option code /Q (e.g. /C01/S01)

[1] POWER INPUT

AC Power

- B: 100 V AC
- C: 110 V AC
- D: 115 V AC
- F: 120 V AC
- G: 200 V AC
- H: 220 V AC
- J: 240 V AC

[2] OPTIONS (multiple selections)

Brake Function

blank: Without

/B : With

Other Options

blank: none

/Q: Option other than the above (specify the specification)

SPECIFICATIONS OF OPTION: Q (multiple selections)

COATING (For the detail, refer to M-System's web site.)

/C01: Silicone coating

/C02: Polyurethane coating

/C03: Rubber coating

TERMINAL SCREW MATERIAL

/S01: Stainless steel

GENERAL SPECIFICATIONS

Construction: Plug-in

Connection: M3.5 screw terminals

Screw terminal: Chromated steel (standard) or stainless steel

Housing material: Flame-resistant resin (black)

Full-closed position adjustment range: 0 - 25 % (front)

Full-open position adjustment range: 75 - 100 % (front)

Preset adjustment range: 0 to 100 % corresponding to Full-closed to Full-open (front)

Deadband: 0.6 - 10.6 % (front)

Timer adjustment: 1 - 30 sec. (front)

Isolation: Contact input to feedback potentiometer to control output to power

Lock protection timer: If the motor doesn't enter the deadband for approx. 2 minutes, then power supply is cut; reset is performed by power OFF or repeating full-open and full-close actions

RUN indicator: Red LED blinks at 0.5 Hz during normal operating

Blinking at 2 Hz when lock protection timer is operating

INPUT SPECIFICATIONS

■ **Setting Signals** (Contact input)

Contact input capacity: 12 V DC @ 2 mA

Detection level: OFF: $\geq 100 \text{ k}\Omega$ ($\leq 0.1 \text{ mA}$) / $\geq 10 \text{ V}$
ON $\leq 5 \text{ k}\Omega$ ($\geq 1 \text{ mA}$) / $\leq 1 \text{ V}$

■ **Feedback potentiometer**

Minimum span: 50% of total resistance

Input range: Can be measured unadjusted from 0 - 100 Ω to 0 - 10 kΩ with potentiometer

Excitation: 1 V DC



Input Assignments

INPUT 0	INPUT 1	INPUT 2	ACTION
OFF	OFF	OFF	Stop
ON	OFF	OFF	Preset Position 1
OFF	ON	OFF	Preset Position 2
ON	ON	OFF	Preset Position 3
OFF	OFF	ON	Preset Position 4
ON	OFF	ON	Full Closed Position
OFF	ON	ON	Full Open Position
ON	ON	ON	Stop

OUTPUT SPECIFICATIONS

■ Control Output: SSR (zero-crossing); 20 - 240 V AC0.1 - 1

A

Operation: Terminal No. in ().

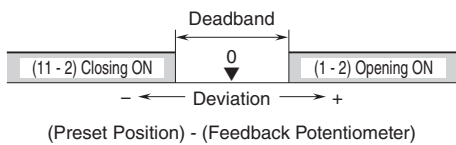

INSTALLATION

Power input

•AC: Operational voltage range: rating $\pm 10\%$,
50/60 ± 2 Hz, approx. 3 VA

Operating temperature: -5 to +60°C (23 to 140°F)

Operating humidity: 30 to 90 %RH (non-condensing)

Mounting: Surface or DIN rail

Weight: 300 g (0.66 lb)

PERFORMANCE

Insulation resistance: ≥ 100 M Ω with 500 V DC

Dielectric strength:

1000 V AC @1 minute (Contact input to position feedback to driver output to power)

2000 V AC @1 minute (Contact input to feedback potentiometer to control output to power to ground)

EXTERNAL VIEW

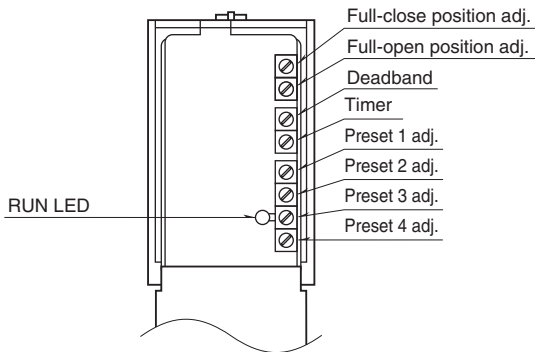

EXTERNAL DIMENSIONS & TERMINAL ASSIGNMENTS unit: mm (inch)

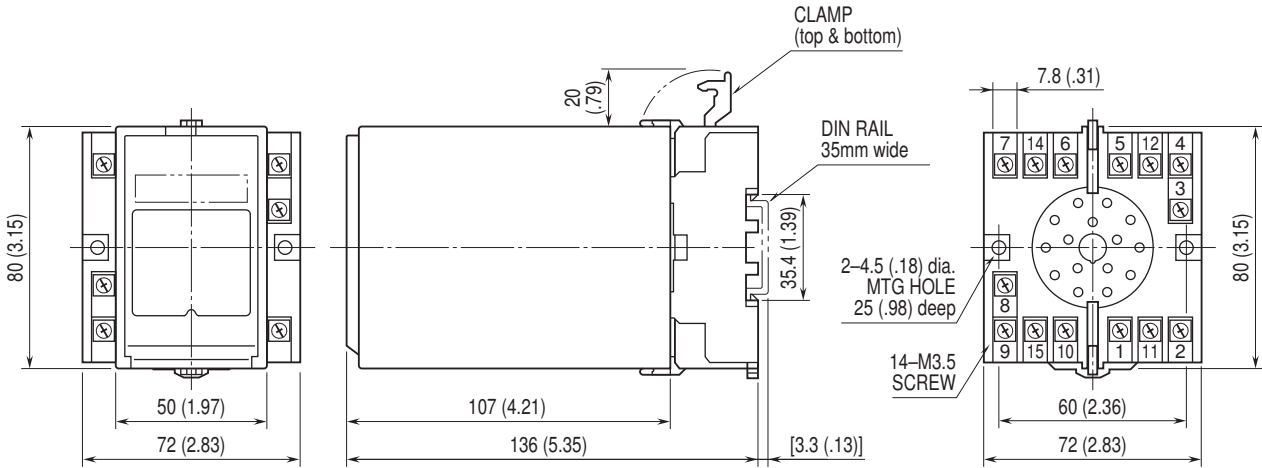

• When mounting, no extra space is needed between units.

SCHEMATIC CIRCUITRY & CONNECTION DIAGRAM

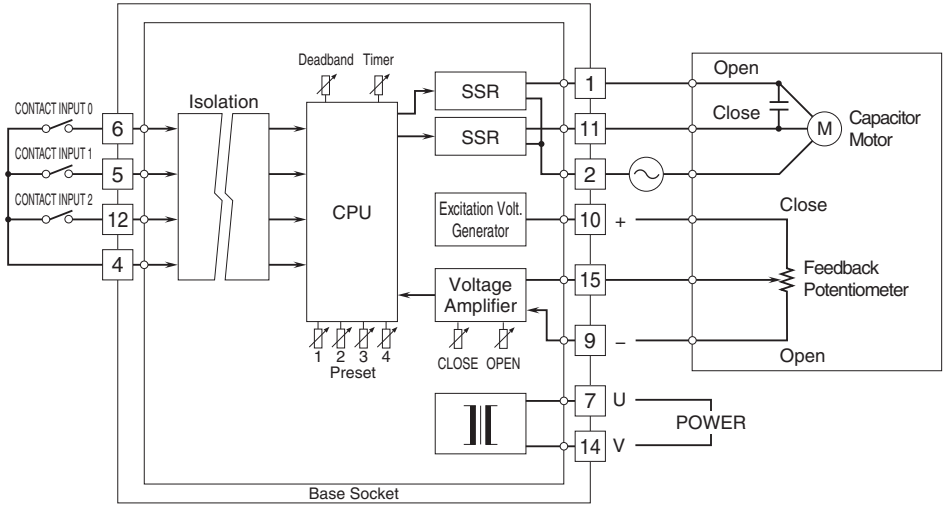

Note: Note that when limit switches inserted in motor wiring, the making/breaking may cause stress on the SSRs.

EXPLANATIONS OF TERMS

•SSR (Solid State Relay)

Composed only of semiconductor parts, SSR is free from arc discharge or chattering which is typical with electromagnetic relays. It features excellent characteristics against vibration, physical impact or other environmental conditions.

•Zero-Cross Function

SSR with zero-cross function turns on when AC power voltage is near zero, creating delay of switching when input is provided in the middle of an wave cycle, thus limiting transient switching noise voltage and rush current.



Specifications are subject to change without notice.

