

Final Control Elements

VALVE POSITIONER

(for Modbus; built-in SSR)

Functions & Features

- Used for control of valve or damper where capacitor motor and potentiometer are employed
- Valve opening and position readable via Modbus communication
- Control of 24 - 200 V AC system electric actuator use
- Built-in SSR directly drives an AC motor

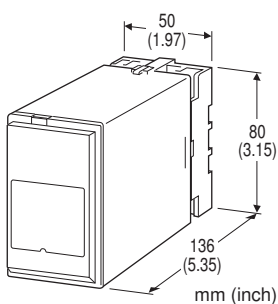

MODEL: MEXM-110-AD4[1]

ORDERING INFORMATION

- Code number: MEXM-110-AD4[1]
Specify a code from below for [1].
(e.g. MEXM-110-AD4/Q)
- Specify the specification for option code /Q
(e.g. /C01/S01)

FEEDBACK RESISTANCE

1: Potentiometer

CONTROL OUTPUT

1: SSRs incorporated

BRAKE

0: None

POWER INPUT

Universal

AD4: 100 - 240 V AC / 100 - 240 V DC (universal)
(Operational voltage range 85 - 264 V AC, 50 - 60 Hz /
85 - 264 V DC, ripple 10 %p-p max.)

[1] OPTIONS

blank: none

/Q: With options (specify the specification)

SPECIFICATIONS OF OPTION: Q (multiple selections)

COATING (For the detail, refer to M-System's web site.)

/C01: Silicone coating

/C02: Polyurethane coating

/C03: Rubber coating

TERMINAL SCREW MATERIAL

/S01: Stainless steel

PACKAGE INCLUDES...

- Terminating resistor (110 Ω, 0.25 W)

GENERAL SPECIFICATIONS

Construction: Plug-in

Connection: M3.5 screw terminals

Screw terminal: Chromated steel (standard) or stainless steel

Housing material: Flame-resistant resin (black)

Full-closed position adjustment range: 0 - 25 % (front)

Full-open position adjustment range: 75 - 100 % (front)

Deadband adjustment: 0.1 - 8.0 % (front adj.; refer to the table below)

Factory set to 1.5 %

Restarting timer: 2 sec.

Isolation: Modbus to feedback resistance to control output to power

Manual operation switch: Manual full-close or full-open position command

Deadband adjustment

SW adjustment	Deadband segment (%)
0	0.1
1	0.3
2	0.5
3	0.7
4	1.0
5	1.5
6	2.0
7	3.0
8	5.0
9	8.0

MODBUS COMMUNICATION

Communication: Half-duplex, asynchronous, no procedure

Standard: Conforms to RS-485, EIA

Baud rate: 4800, 9600, 19.2 k, 38.4 k (bps) (with rotary switch) (factory default: 38.4 kbps)

Protocol: Modbus - RTU

Node address setting: 1 - 99 (with rotary switch) (factory



default: 00)

Parity: None, even or odd (with DIP switch) (factory default: odd)

Stop bit: 1 or 2 (with DIP switch) (factory default: 1)

Segment max. length: 500m

Max. number of nodes: 31 (excluding master)

Modbus LED: Blink in normal communication

Measurement Category II (control output)

Pollution degree 2

Modbus or control output or feedback resistance to power:

Reinforced insulation (300 V)

Modbus or feedback resistance to control output:

Reinforced

insulation (250 V)

INPUT SPECIFICATIONS

• **Feedback Potentiometer:** 100 Ω - 10 k Ω

Minimum span: 50 % of total resistance

Excitation: Approx. 3.3 V DC

OUTPUT SPECIFICATIONS

■ **Control Output:** SSR (zero-crossing); 20-240 V AC 0.1-1 A

Leakage current at OFF: Approx. 10 mA @ 240 V AC

Output operation: Terminal no. in ().

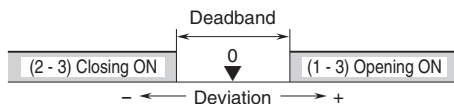

INSTALLATION

Power input

• **AC:**

approx. 1.5 VA at 100 V

approx. 4 VA at 200 V

approx. 6 VA at 264 V

• **DC:** Approx. 1 W

Operating temperature: -5 to +60°C (23 to 140°F)

Operating humidity: 30 to 90 %RH (non-condensing)

Atmosphere: No corrosive gas or heavy dust

Mounting: Surface or DIN rail

Weight: 300 g (0.66 lb)

PERFORMANCE

Insulation resistance: \geq 100 M Ω with 500 V DC

Dielectric strength: 2000 V AC @ 1 minute

(Modbus to feedback resistance to control output to power to ground)

STANDARDS & APPROVALS

Refer to the manuals to comply with the standards.

CE conformity:

EMC Directive (2004/108/EC)

EMI EN 61000-6-4: 2007

EMS EN 61000-6-2: 2005

Low Voltage Directive (2006/95/EC)

EN 61010-1: 2001

Installation Category II (power)



幸託有限公司
XIN TOP CORPORATION

TEL : (02)2598-1199

FAX : (02)2596-2331

E-mail : info@xintop.com

Website : www.xintop.com

EXTERNAL VIEW

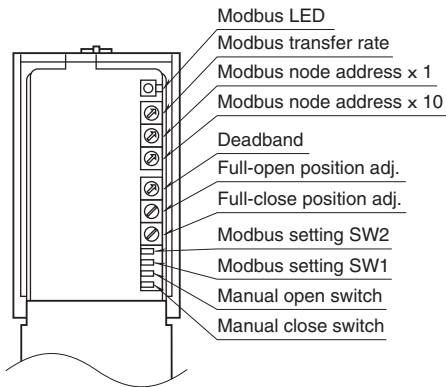

MODBUS WIRING CONNECTION

■ HOST PC WIRING

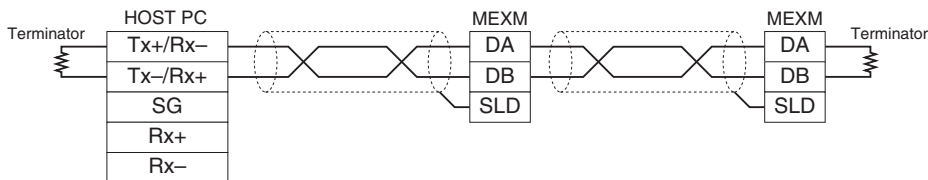

Connect terminating resistor between DA and DB of both ends of the unit.
 Connect the attached terminating resistor to the MEXM.
 Master unit is connectable also at both ends or other points.

EXTERNAL DIMENSIONS & TERMINAL ASSIGNMENTS unit: mm (inch)

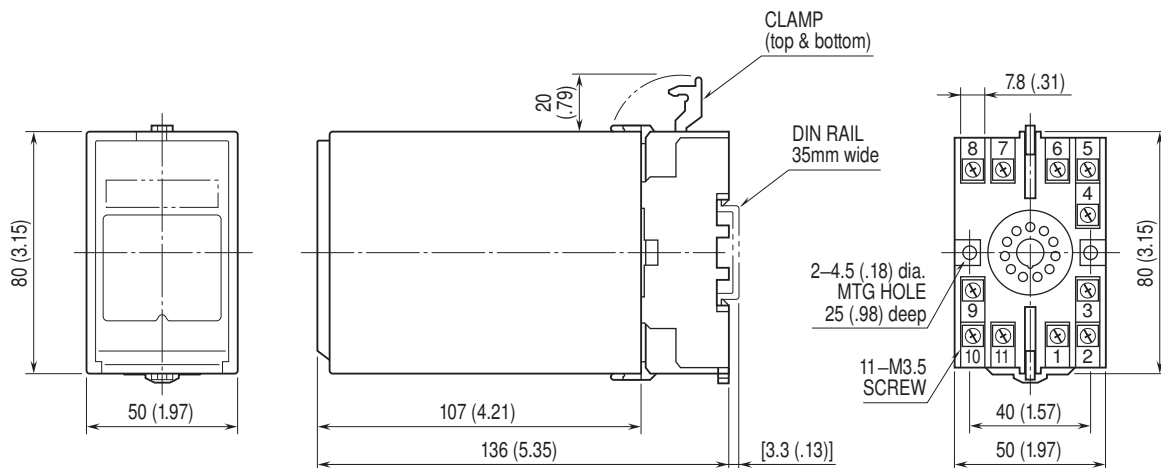

• When mounting, no extra space is needed between units.

SCHEMATIC CIRCUITRY & CONNECTION DIAGRAM

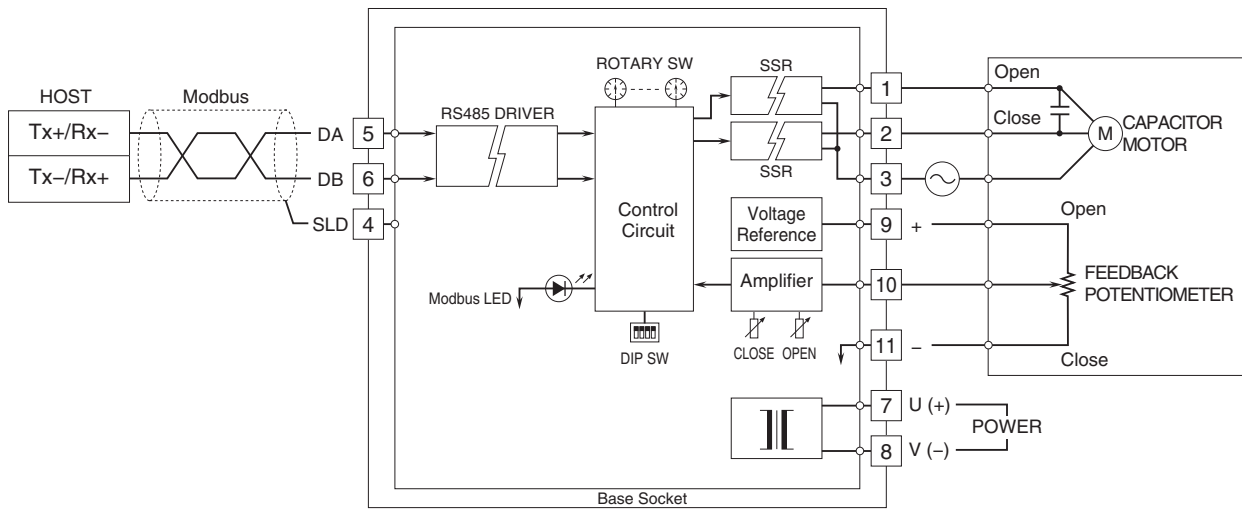

Note: Notice that making motor wiring with limit switch, every time the switch operates, can be causing stress on SSR.

EXPLANATIONS OF TERMS

•SSR (Solid State Relay)

Composed only of semiconductor parts, SSR is free from arc discharge or chattering which is typical with electromagnetic relays. It features excellent characteristics against vibration, physical impact or other environmental conditions.

•Zero-Cross Function

SSR with zero-cross function turns on when AC power voltage is near zero, creating delay of switching when input is provided in the middle of an wave cycle, thus limiting transient switching noise voltage and rush current.



Specifications are subject to change without notice.