

Final Control Elements

VALVE POSITIONER

(for LonWorks; built-in SSR)

Functions & Features

- LonWorks compatible
- Used for 24 - 200 V AC electric actuator position control
- Position feedback via potentiometer (100 Ω - 10 kΩ unadjusted)
- Direct motor driving with built-in SSR (with zero-cross circuit)
- Restart control timer built-in to prevent motor overheating due to frequent on/off switching

Typical Applications

- Retrofitting existing equipment for LonWorks compatibility

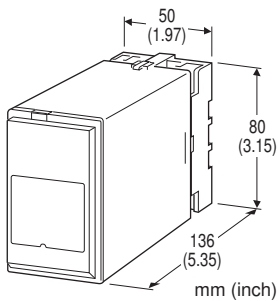

MODEL: MEXL-11[1]-[2][3]

ORDERING INFORMATION

- **Code number:** MEXL-11[1]-[2][3]
- Specify a code from below for each [1] through [3].
(e.g. MEXL-111-G/Q)
- Specify the specification for option code /Q (e.g. /C01/S01)

FEEDBACK RESISTANCE

1: Potentiometer

CONTROL OUTPUT

1: SSRs incorporated

[1] BREAK

0: None
1: With

[2] POWER INPUT

AC Power
A: 24 V AC
B: 100 V AC

C: 110 V AC
G: 200 V AC
H: 220 V AC

[3] OPTIONS

Other Options

blank: none
/Q: With options (specify the specification)

SPECIFICATIONS OF OPTION: Q (multiple selections)

COATING (For the detail, refer to M-System's web site.)

/C01: Silicone coating
/C02: Polyurethane coating
/C03: Rubber coating

TERMINAL SCREW MATERIAL

/S01: Stainless steel

EXTERNAL INTERFACE FILE

MEXL external interface file MEXL.XIF downloadable at M-System's web site.

GENERAL SPECIFICATIONS

Construction: Plug-in

Connection: M3.5 screw terminals

Screw terminal: Chromated steel (standard) or stainless steel

Housing material: Flame-resistant resin (black)

Full-closed position adjustment range: 0 - 25 % (front)

Full-open position adjustment range: 75 - 100 % (front)

Deadband adjustment: 0.1 - 8.0 % (front adj.; refer to the table below)

Isolation: LonWorks to feedback potentiometer to control output to power to ground

RUN LED:

Blinking at 0.5 Hz in normal operating conditions

Blinking at 2 Hz when lock protection timer is operating

Blinking at 5 Hz for 3 seconds during Wink

Manual operation switch: Manual full-close or full-open position command

Deadband adjustment

Deadband adj. SW	Deadband (%)
0	0.1
1	0.3
2	0.5
3	0.7
4	1.0
5	1.5
6	2.0
7	3.0
8	5.0
9	8.0



幸託有限公司
XIN TOP CORPORATION

TEL : (02)2598-1199
FAX : (02)2596-2331

E-mail : info@xintop.com
Website : www.xintop.com

LonWorks COMMUNICATION

Neuron chip: TMPN3120

Transceiver: FTT-10A (78 kbps, free topology)

Service pin: Node structure, for installation

Reset switch: Neuron chip reset

Service LED: ON when no valid application code is held or when malfunctioning

Blinking at 0.5 Hz when network address information is not configured

INPUT SPECIFICATIONS

• **Feedback potentiometer:** 100 Ω - 10 k Ω

Minimum span: 50 % of total resistance

Excitation: 3.3 V DC

OUTPUT SPECIFICATIONS

■ **Control Output:** SSR (zero-crossing); 20 - 240 V AC 0.1 - 1 A

Output operation: Terminal no. in ().

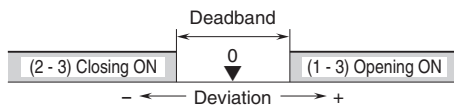

INSTALLATION

Power input

• **AC:** Operational voltage range: rating ± 10 %, 50/60 ± 2 Hz, approx. 3 VA

Operating temperature: -5 to +60°C (23 to 140°F)

Operating humidity: 30 to 90 %RH (non-condensing)

Mounting: Surface or DIN rail

Weight: 300 g (0.66 lb)

PERFORMANCE

Insulation resistance: ≥ 100 M Ω with 500 V DC

Dielectric strength: 2000 V AC @ 1 minute (LonWorks or feedback potentiometer to control output to power to ground)

500 V AC @ 1 minute (LonWorks to feedback potentiometer)



EXTERNAL VIEW

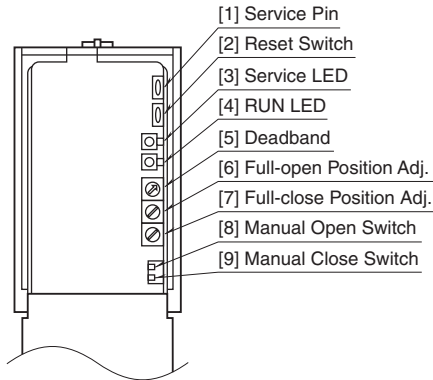

NETWORK VARIABLES

Refer to the instruction manual for details.

Node Object #0

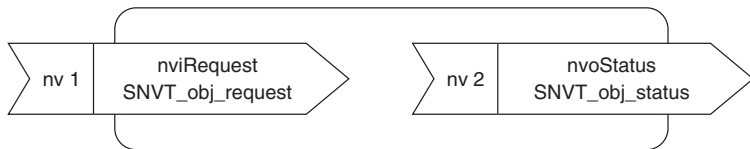

Application Object #1

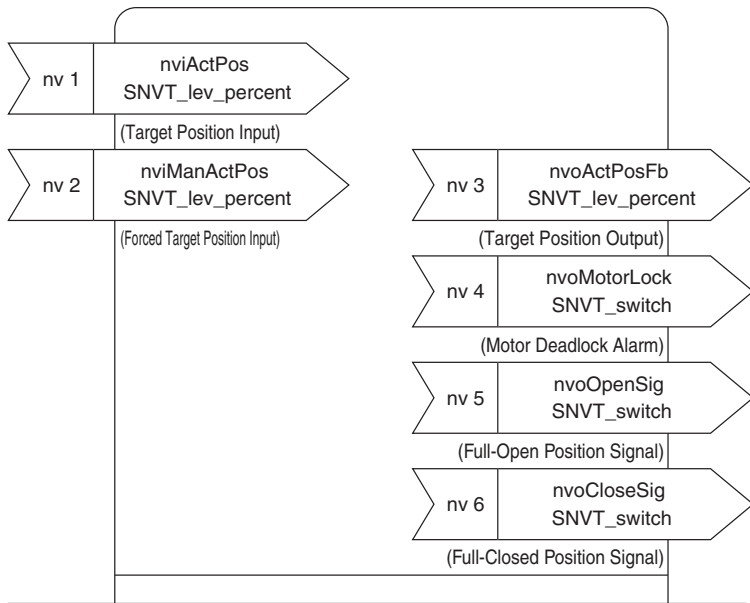

Configuration Parameter

nciDelayTime	SNVT_time_sec	(Send Start Delay Time)
nciSndHrtBt	SNVT_time_sec	(Send Time Interval)
nciActPosSndDiff	SNVT_lev_percent	(Target position change triggering send)
nciErrDetectTime	SNVT_time_sec	(Motor Deadlock Detection Time)
nciOpenSigPos	SNVT_lev_percent	(Full-open Signal Threshold)
nciCloseSigPos	SNVT_lev_percent	(Full-closed Signal Threshold)
nciRestartTime	SNVT_time_sec	(Restart Limiting Timer)



EXTERNAL DIMENSIONS & TERMINAL ASSIGNMENTS unit: mm (inch)

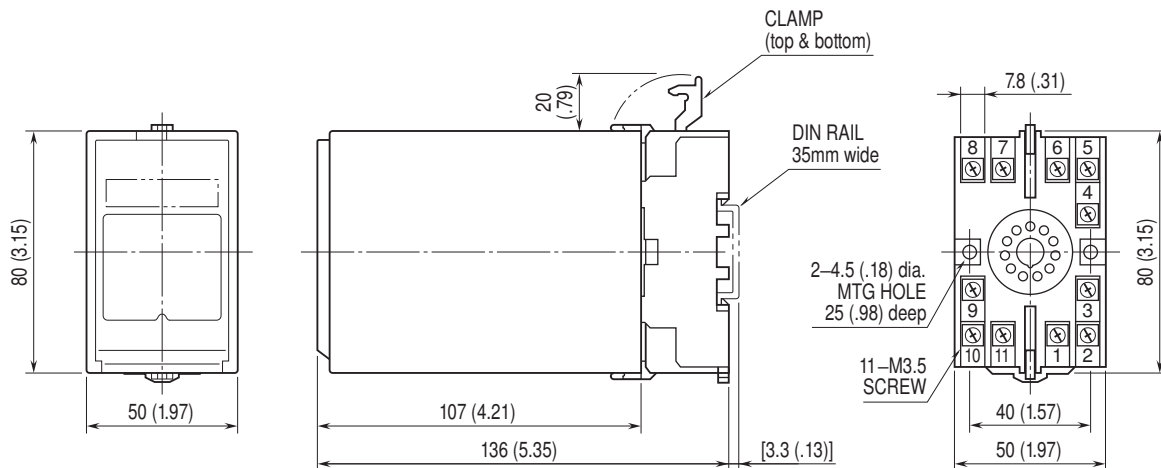

• When mounting, no extra space is needed between units.

SCHEMATIC CIRCUITRY & CONNECTION DIAGRAM

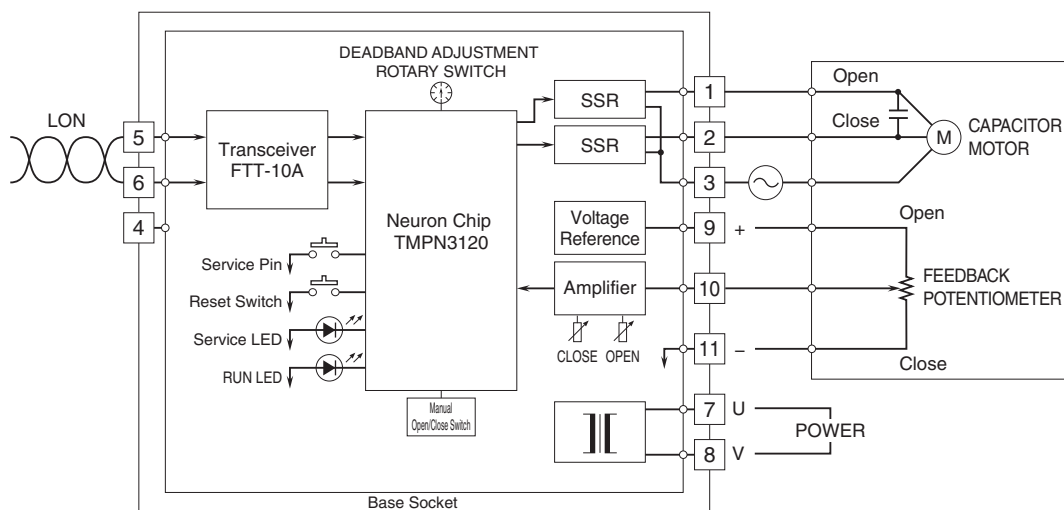

Note: Note that when limit switches inserted in motor wiring, the making/breaking may cause stress on the SSRs.

EXPLANATIONS OF TERMS

•SSR (Solid State Relay)

Composed only of semiconductor parts, SSR is free from arc discharge or chattering which is typical with electromagnetic relays. It features excellent characteristics against vibration, physical impact or other environmental conditions.

•Zero-Cross Function

SSR with zero-cross function turns on when AC power voltage is near zero, creating delay of switching when input is provided in the middle of an wave cycle, thus limiting transient switching noise voltage and rush current.



Specifications are subject to change without notice.

