

## Final Control Elements

### VALVE POSITIONER

(current feedback; built-in SSR)

#### Functions & Features

- Controlling an electric actuator powered with 100 V AC
- Feedback current 4 - 20 mA DC
- Built-in SSR directly drives an AC motor
- Timer for motor's overheat protection
- Re-transmitted output

#### Typical Applications

- Single phase AC motor
- Loop powered isolator can be used for isolating between setpoint input signal and transmitter output signal

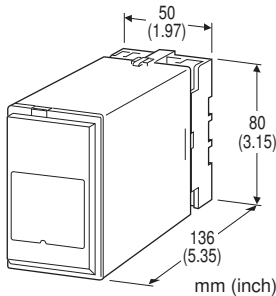

## MODEL: MEX-D-[1][2]

### ORDERING INFORMATION

- Code number: MEX-D-[1][2]  
Specify a code from below for each [1] and [2].  
(e.g. MEX-D-B/Q)
- Specify the specification for option code /Q  
(e.g. /C01/S01)

### [1] POWER INPUT

#### AC Power

- B: 100 V AC
- C: 110 V AC
- D: 115 V AC
- F: 120 V AC
- G: 200 V AC
- H: 220 V AC
- J: 240 V AC

### [2] OPTIONS

blank: none

/Q: With options (specify the specification)

### SPECIFICATIONS OF OPTION: Q (multiple selections)

#### COATING (For the detail, refer to M-System's web site.)

- /C01: Silicone coating
- /C02: Polyurethane coating
- /C03: Rubber coating

#### TERMINAL SCREW MATERIAL

- /S01: Stainless steel

### GENERAL SPECIFICATIONS

**Construction:** Plug-in

**Connection:** M3.5 screw terminals

**Screw terminal:** Chromated steel (standard) or stainless steel

**Housing material:** Flame-resistant resin (black)

**Deadband adjustment:** 2 - 20 % (front)

**Timer adjustment:** 1 - 30 sec. (front)

**Isolation:** Input or xmtr output to output to power

**Zero adjustment:** -10 to +10 % (front)

**Span adjustment:** 90 to 110 % (front)

### INPUT SPECIFICATIONS

- **Setpoint Signal:** 4 - 20 mA DC; input resistor incorporated

**Input resistance:** 100 Ω

- **Feedback Current:** 4 - 20 mA DC; input resistor incorporated

**Input resistance:** 20 Ω

### OUTPUT SPECIFICATIONS

- **Re-Transmitted Output:** 4 - 20 mA DC

**Load resistance:** 750 Ω max.

- **Control Output:** SSR (zero-crossing);

60 - 280 V AC @ 0.1 - 1 A

Note 1: The incorporated SSR is not capable for driving 200 V AC motor.

Note 2: When driving relays with this control output, relays may operate erratically due to the leakage current at OFF of SSR. To avoid the problem, install a resistor (R) in parallel with the relay coil.

$$R < \frac{[\text{Release Voltage}] \div [[\text{Leakage Current at OFF}] - [\text{Release Current}]]}{[\text{Release Current}]}$$

**Leakage current at OFF:** Approx. 10 mA @ 240 V

• **Output Operation** (terminal No. in parentheses)

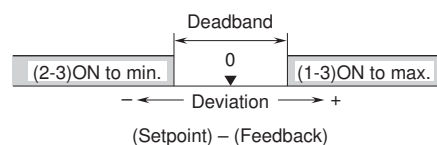

## INSTALLATION

### Power input

•AC: Operational voltage range: rating  $\pm 10\%$ ,  
50/60  $\pm 2$  Hz, approx. 3 VA

**Operating temperature:** -5 to +60°C (23 to 140°F)

**Operating humidity:** 30 to 90 %RH (non-condensing)

**Mounting:** Surface or DIN rail

**Weight:** 300 g (0.66 lb)

## PERFORMANCE in percentage of span

**Position conversion accuracy:**  $\pm 0.5\%$

**Insulation resistance:**  $\geq 100\text{ M}\Omega$  with 500 V DC

**Dielectric strength:** 1000 V AC @ 1 minute

(input or xmtr output to output to power)

2000 V AC @ 1 minute (input or xmtr output or output or  
power to ground)

## EXTERNAL VIEW

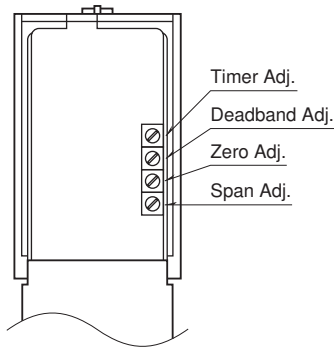

## EXTERNAL DIMENSIONS & TERMINAL ASSIGNMENTS unit: mm (inch)

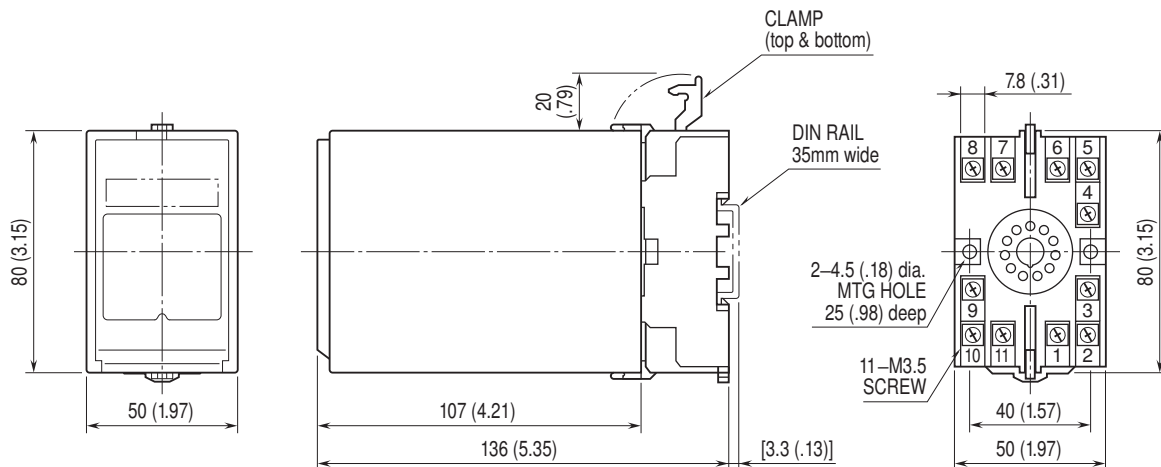

• When mounting, no extra space is needed between units.



**SCHEMATIC CIRCUITRY & CONNECTION DIAGRAM**

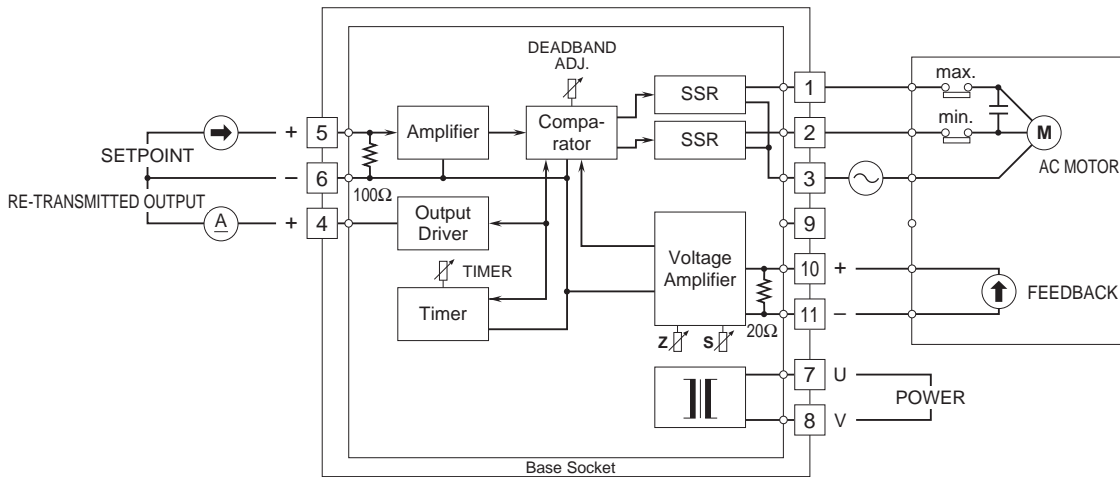

**EXPLANATIONS OF TERMS**

•SSR (Solid State Relay)

Composed only of semiconductor parts, SSR is free from arc discharge or chattering which is typical with electromagnetic relays. It features excellent characteristics against vibration, physical impact or other environmental conditions.

•Zero-Cross Function

SSR with zero-cross function turns on when AC power voltage is near zero, creating delay of switching when input is provided in the middle of an wave cycle, thus limiting transient switching noise voltage and rush current.



Specifications are subject to change without notice.

