

Plug-in Signal Conditioners M-UNIT

PHASE ANGLE TRANSDUCER

Functions & Features

- Providing a DC output signal in proportion to phase angle
- DC output containing little ripple is ideal for computer input
- Isolation up to 2000 V AC
- High-density mounting

Typical Applications

- Centralized monitoring and control of power management system in a manufacturing facility or building
- Measuring phase angle for a motor

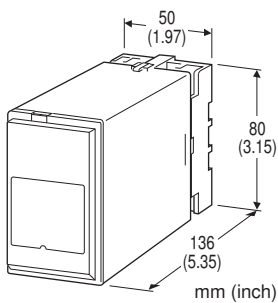

MODEL: MEPA-1[1][2][3]-[4] [5]

ORDERING INFORMATION

- Code number: MEPA-1[1][2][3]-[4][5]
- Specify a code from below for each [1] through [5].
(e.g. MEPA-11PA-C/Q)
- Special output range (For codes Z & 0)
- Specify the specification for option code /Q
(e.g. /C01/S01)

CONFIGURATION

1: 3-phase / 3-wire

[1] INPUT (balanced load)

- 1: 110 V / 5 A AC
- 2: 110 V / 1 A AC
- 3: 220 V / 1 A AC
- 4: 220 V / 5 A AC

[2] OUTPUT SIGNAL POLARITY

- P: Negative in lag, positive in lead
- M: Negative in lead, positive in lag

[3] OUTPUT

Current

- A: 4 - 20 mA DC (Load resistance 600 Ω max.)
- B: 2 - 10 mA DC (Load resistance 1200 Ω max.)
- C: 1 - 5 mA DC (Load resistance 2400 Ω max.)
- D: 0 - 20 mA DC (Load resistance 600 Ω max.)
- E: 0 - 16 mA DC (Load resistance 750 Ω max.)
- F: 0 - 10 mA DC (Load resistance 1200 Ω max.)
- G: 0 - 1 mA DC (Load resistance 12 kΩ max.)
- GW: -1 - +1 mA DC (Load resistance 10 kΩ max.)
- Z: Specify current (See OUTPUT SPECIFICATIONS)

Voltage

- 1: 0 - 10 mV DC (Load resistance 10 kΩ min.)
- 2: 0 - 100 mV DC (Load resistance 100 kΩ min.)
- 3: 0 - 1 V DC (Load resistance 1000 Ω min.)
- 4: 0 - 10 V DC (Load resistance 10 kΩ min.)
- 5: 0 - 5 V DC (Load resistance 5000 Ω min.)
- 6: 1 - 5 V DC (Load resistance 5000 Ω min.)
- 1W: -10 - +10 mV DC (Load resistance 10 kΩ min.)
- 2W: -100 - +100 mV DC (Load resistance 100 kΩ min.)
- 3W: -1 - +1 V DC (Load resistance 1000 Ω min.)
- 4W: -10 - +10 V DC (Load resistance 10 kΩ min.)
- 5W: -5 - +5 V DC (Load resistance 5000 Ω min.)
- 0: Specify voltage (See OUTPUT SPECIFICATIONS)

[4] POWER INPUT

AC Power

- B: 100 V AC
- C: 110 V AC
- D: 115 V AC
- F: 120 V AC
- G: 200 V AC
- H: 220 V AC
- J: 240 V AC

DC Power

- S: 12 V DC
- R: 24 V DC
- V: 48 V DC
- P: 110 V DC

[5] OPTIONS

Other Options

- blank: none
- /Q: With options (specify the specification)

SPECIFICATIONS OF OPTION: Q (multiple selections)

COATING (For the detail, refer to M-System's web site.)

- /C01: Silicone coating
- /C02: Polyurethane coating
- /C03: Rubber coating

TERMINAL SCREW MATERIAL



/S01: Stainless steel

GENERAL SPECIFICATIONS

Construction: Plug-in
Connection: M3.5 screw terminals
Screw terminal: Nickel-plated steel (standard) or stainless steel
Housing material: Flame-resistant resin (black)
Isolation: Voltage input to current input to output to power
Overrange output: Approx. -10 to +120 % at 1 - 5 V
Zero adjustment: -5 to +5 % (front)
Span adjustment: 95 to 105 % (front)

INPUT SPECIFICATIONS

Frequency: 50 / 60 Hz

- **Current Input**
Input burden: ≤ 0.1 VA (Input 1A)
 ≤ 0.5VA (Input 5A)
Operational range: 10 - 120% of rated value
Overload capacity: 1000% @ 3 sec., 200% @ 10 sec., 120% continuous
- **Voltage Input**
Input burden: Approx. 0.5 VA
Operational range: 85 - 120% of rated value
Overload capacity: 150% @ 10 sec., 120% continuous

■ **Input range:**
 Lag 60° - 0 - lead 60°
 Lead 60° - 0 - lag 60°

OUTPUT SPECIFICATIONS

■ **DC Output**
 • **DC Current:** 0 - 20 mA DC and ±1 mA
Minimum span: 1 mA
Offset: ≤ 1.5 times span
Load resistance: Output drive 12 V max.; 10 V for [±] output

■ **DC Voltage:** -10 - +12 V DC
Minimum span: 5 mV
Offset: Max. 1.5 times span
Load resistance: Output drive 1 mA max. at ≥ 0.5 V

OPERATION DIAGRAM (example)

• Negative in lag, positive in lead

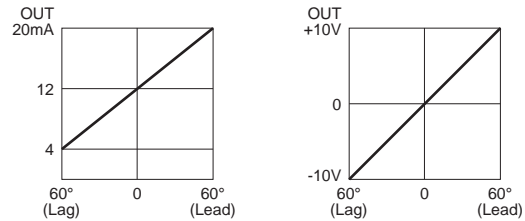

• Negative in lead, positive in lag

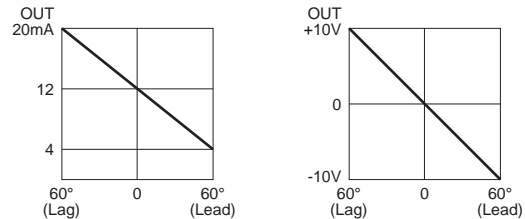

Remark: When there is no input voltage or 5% or less of the rated input current, the output may become unstable (hunting).

INSTALLATION

Power input

- **AC:** Operational voltage range: rating -15/+10 %, 50/60 Hz, approx. 2 VA
- **DC:** Operational voltage range: rating ±10 %, or 85 - 150 V for 110 V rating, ripple 10 %p-p max., approx. 2 W (18 mA at 110 V)

Operating temperature: -5 to +60°C (23 to 140°F)
Operating humidity: 30 to 90 %RH (non-condensing)
Mounting: Surface or DIN rail
Weight: 400 g (0.88 lb)

PERFORMANCE in percentage of span

Accuracy: ±2 % with balanced load
Temp. coefficient: ±0.2 %/°C (±0.11 %/°F)
Response time: ≤ 1 sec. (0 - 90 %)
Ripple: 0.5 %p-p max. (50/60 Hz)
Line voltage effect: ±0.1 % over voltage range
Insulation resistance: ≥ 100 MΩ with 500 V DC
Dielectric strength: 2000 V AC @ 1 minute
 (voltage input to current input to output to power to ground)



CONNECTION DIAGRAM

3-PHASE / 3-WIRE

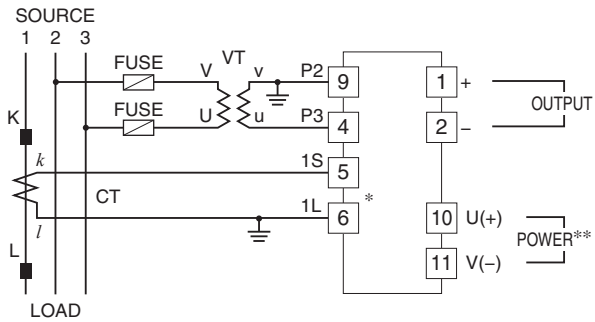

*CT Protector (model: CTM) is attached.

**The transducer can be powered from the input voltage when the voltage is sufficiently stable and meets other supply voltage requirements.

DIMENSIONS unit: mm (inch)

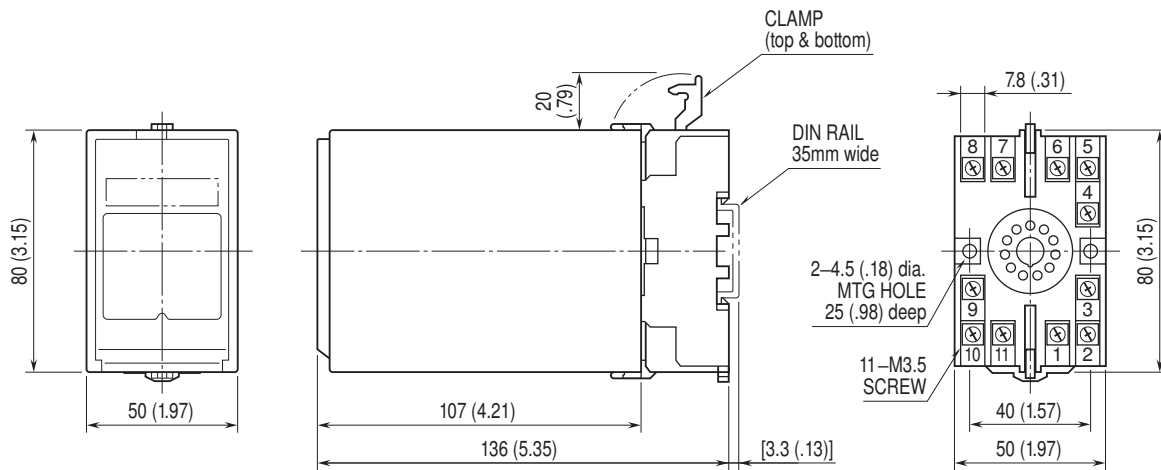

• When mounting, no extra space is needed between units.

TERMINAL ASSIGNMENTS unit: mm (inch)

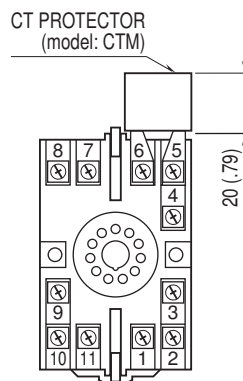

Specifications are subject to change without notice.

