

Dual Output Super-mini Signal Conditioners Pico-M Series

POTENTIOMETER CONVERTER

(PC programmable)

Functions & Features

- Provides two isolated DC outputs proportional to a potentiometer or slidewire position input
- PC programmable
- Captures zero/span points using front switches
- Space-saving, easy-to-maintain, multi-channel installation base

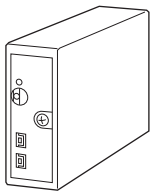

MODEL: M8XM2-[1]-R[2]

ORDERING INFORMATION

- Code number: M8XM2-[1]-R[2]
Specify a code from below for each [1] and [2].
(e.g. M8XM2-V2V2-R/Q)
 - Specify the specification for option code /Q
(e.g. /C01)
 - Input Range (e.g. 0 - 800 Ω)
 - Output 1 / Output 2 (e.g. 1 - 5 V / 1 - 5 V DC)
- If no I/O specifications are specified, model M8XM2-V2V2-R/Q will be shipped.
[Total resistance 1k Ω , V2V2: 1 - 5 V DC / 1 - 5 V DC]
- Use Ordering Information Sheet (No. ESU-5472) to specify linearization data when the I/O signals are nonlinear. Linear data will be programmed if not otherwise specified.

INPUT POTENTIOMETER

Total resistance 50 Ω - 8 k Ω
(Configurator software is used to change the input range.)

[1] OUTPUT 1 / OUTPUT 2

V2Z1: Range -10 - +10 V DC / Range 0 - 20 mA DC
V2V2: Range -10 - +10 V DC / Range -10 - +10 V DC
(Configurator software is used to change output over the described range of the selected suffix code.
For changing between suffix codes, set the Output Range Selector on the side of unit before software adjustment.)

POWER INPUT

DC Power
R: 24 V DC
(Operational voltage range 24 V \pm 10 %, ripple 10 %p-p max.)

[2] OPTIONS

blank: none
/Q: With options (specify the specification)

SPECIFICATIONS OF OPTION: Q

COATING (For the detail, refer to M-System's web site.)
/C01: Silicone coating
/C02: Polyurethane coating
/C03: Rubber coating

RELATED PRODUCTS

- Installation Base or Single Mount Base Socket (model: M8BSx)
This unit must be mounted on dedicated base or socket.
- JX configurator connection kit (model: JXCON)

GENERAL SPECIFICATIONS

Construction: Plug-in
Mounting screw: M3 screw (torque 0.3 N·m)
Housing material: Flame-resistant resin (black)
Power supply: Via the Installation Base terminals (model: M8BSx)
Isolation: Input to output 1 to output 2 to power
Overrange output: Approx. -15 to +115 %
Manual zero adjustments: -5 to +5 %
(factory setting: 0 %)
Manual span adjustments: 95 to 105 %
(factory setting: 100 %)
Programming: Downloaded from PC; input range (total resistance), output range, zero and span, simulating output, linearization, etc.
Burnout protection: Upscale standard; downscale or no burnout optional by programming
Status indicator LED: Blinking patterns indicate different operating status of the transmitter.
Configurator connection: 2.5 dia. miniature jack; RS-232-C level

INPUT SPECIFICATIONS

Minimum span
(Input Range (Total Resistance): Minimum Span)
0 - 50 Ω (50 Ω): 2.5 Ω
0 - 100 Ω (50 - 100 Ω): 3 Ω
0 - 250 Ω (100 - 250 Ω): 3 Ω
0 - 800 Ω (250 - 800 Ω): 10 Ω



0 - 8 k Ω (800 Ω - 8 k Ω): 10 Ω

Excitation: \leq 0.65 V DC at 1 k Ω

If not specified, the total resistance is 1 k Ω .

OUTPUT SPECIFICATIONS

■ **DC Current:** 0 - 20 mA DC

Operational range: 0 - 24 mA DC

Minimum span: 1 mA

Offset: Lower range can be any specific value within the output range provided that the minimum span is maintained.

Load resistance: Output drive 6 V max.

(e.g. 4 - 20 mA: 300 Ω [6 V \div 20 mA])

■ **DC Voltage:** -10 - +10 V DC

Operational range: -11.5 - +11.5 V DC

Minimum span: 1 V

Offset: Lower range can be any specific value within the output range provided that the minimum span is maintained.

Load resistance: Output drive 1 mA max.

(e.g. 1 - 5 V: 5000 Ω [5 V \div 1 mA])

If not specified, the output range is shown below.

V2Z1: 1 - 5 V / 4 - 20 mA DC

V2V2: 1 - 5 V / 1 - 5 V DC

Line voltage effect: \pm 0.1 % over voltage range

Insulation resistance: \geq 100 M Ω with 500 V DC

Dielectric strength:

1500 V AC @1 minute (input to output 1 or output 2 or power to ground)

500 V AC @1 minute (output 1 to output 2 to power)

HOW TO CALCULATE THE ACCURACY

■ **Overall Accuracy**

[Example] Total resistance 800 Ω , 250 - 750 Ω input, 1 - 5 V output

Input Accuracy

= Max. Range \div Input Span \times Input Accuracy

= 800 \div 500 \times 0.01

= 0.02

Output Accuracy

= Max. Range \div Output Span \times Output Accuracy

= 20 \div 4 \times 0.02 = 0.1

Overall Accuracy

= 0.02 + 0.1

= \pm 0.12 %

INSTALLATION

Current consumption: Approx. 50 mA (70 mA for current output)

Operating temperature: 0 to 55 $^{\circ}$ C (32 to 131 $^{\circ}$ F)

Operating humidity: 30 to 95 %RH (non-condensing)

Mounting: Installation Base (model: M8BSx)

Weight: 70 g (2.5 oz)

PERFORMANCE

Overall accuracy:

Input accuracy + output accuracy [gain \leq 1]

(inp. accuracy + out. accuracy) \times gain [gain $>$ 1]

Inversely proportional to the span.

See HOW TO CALCULATE THE ACCURACY.

• **Input accuracy:** (% of input range)

0 - 50 Ω : \pm 0.02 %

0 - 100 Ω : \pm 0.02 %

0 - 250 Ω : \pm 0.01 %

0 - 800 Ω : \pm 0.01 %

0 - 8 k Ω : \pm 0.02 %

• **Output accuracy:** (% of output range)

-10 - +10 V : \pm 0.02 %

0 - 20 mA : \pm 0.04 %

Temp. coefficient: \pm 0.015 %/ $^{\circ}$ C (\pm 0.008 %/ $^{\circ}$ F) of I/O range

at 0 to 55 $^{\circ}$ C [32 to 131 $^{\circ}$ F]

Response time: \leq 0.9 sec. (0 - 90 %)



幸託有限公司

XIN TOP CORPORATION

TEL : (02)2598-1199

FAX : (02)2596-2331

E-mail : info@xintop.com

Website : www.xintop.com

EXTERNAL VIEWS

■SIDE VIEW

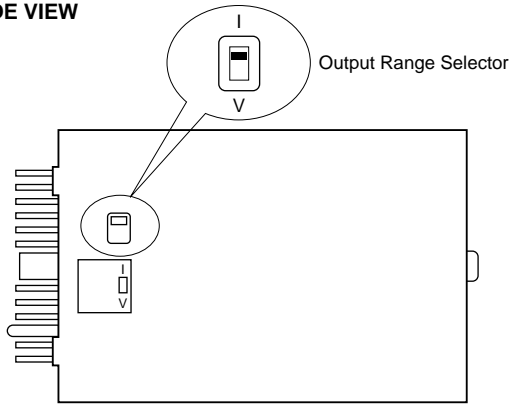

■FRONT VIEW

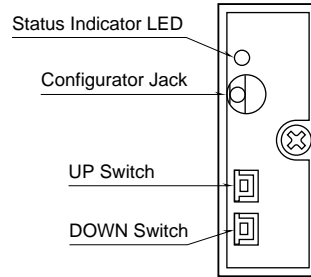

■BOTTOM VIEW

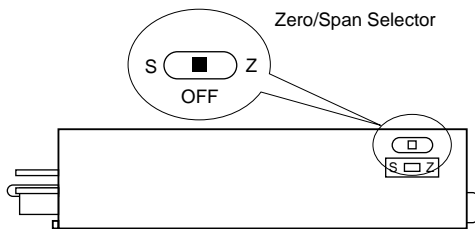

Output Range Selector

(SW POSITION: RANGE)

I: V2Z1 (-10 - +10 V / 0 - 20 mA DC)

V: V2V2 (-10 - +10 V / -10 - +10 V DC)

Zero/Span Selector

(SW POSITION: MODE)

S: SPAN

Center: OFF

Z: ZERO

Zero/Span is calibrated by using UP/DOWN switches when the calibration mode is set. Refer to the instruction manual for detailed procedures.

DIMENSIONS unit: mm (inch)

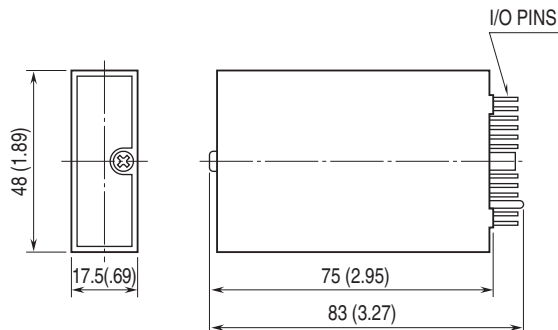

SCHEMATIC CIRCUITRY & CONNECTION DIAGRAM

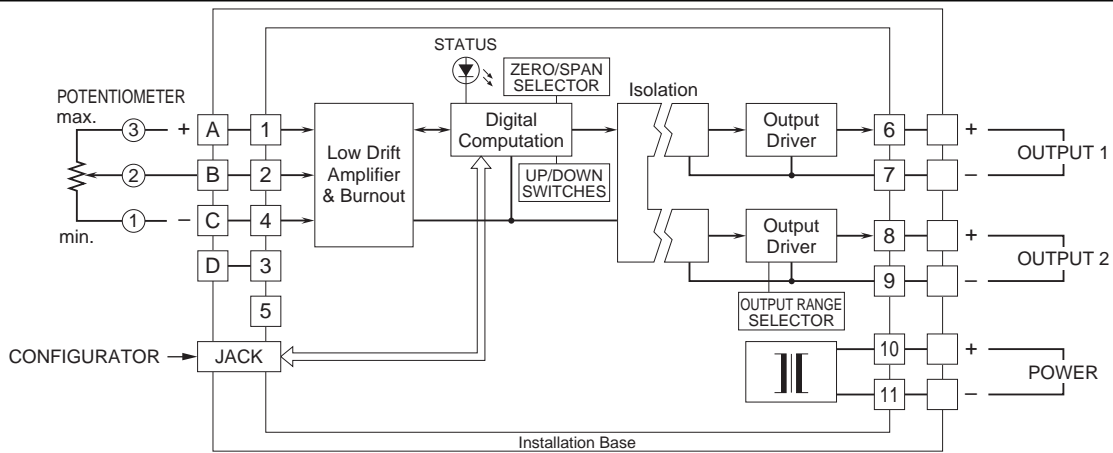

Specifications are subject to change without notice.

