

FREQUENCY CONVERTER

(CE)

Functions & Features

- Converting the output from a pulse-type transducer into a standard process signal
- Space-saving, easy-to-maintain, multi-channel installation base

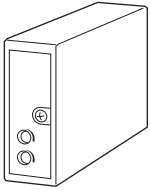

MODEL: M8PA1-[1][2]-R[3]

ORDERING INFORMATION

- Code number: M8PA1-[1][2]-R[3]
Specify a code from below for each [1] trough [3].
(e.g. M8PA1-A6A-R/Q)
- Frequency range (e.g. 0 - 1 kHz)
Use Ordering Information Sheet (No. ESU-5484) for Input Codes B: DC voltage pulse or E: AC voltage pulse.
- Specify the specification for option code /Q
(e.g. /C01/V01)

[1] INPUT

- A: Dry contact
- B: DC voltage pulse (Specify sensitivity)
- C: 5 V pulse (sensitivity 2 V)
- D: 12 V/24 V pulse (sensitivity 5 V)
- E: AC voltage pulse (Specify sensitivity)

[2] OUTPUT 1 / OUTPUT 2

- 6A: 1 - 5 V DC (Load resistance 2500 Ω min.)
/ 4 - 20 mA DC (Load resistance 300 Ω max.)
- 44: 0 - 10 V DC (Load Resistance 5000 Ω min.)
/ 0 - 10 V DC (Load Resistance 5000 Ω min.)
- 55: 0 - 5 V DC (Load resistance 2500 Ω min.)
/ 0 - 5 V DC (Load resistance 2500 Ω min.)
- 66: 1 - 5 V DC (Load resistance 2500 Ω min.)
/ 1 - 5 V DC (Load resistance 2500 Ω min.)

POWER INPUT

- DC Power
- R: 24 V DC

[3] OPTIONS

- blank: none
- /Q: With options (specify the specification)

SPECIFICATIONS OF OPTION: Q (multiple selections)

COATING (For the detail, refer to M-System's web site.)

- /C01: Silicone coating
- /C02: Polyurethane coating
- /C03: Rubber coating

ADJUSTMENT

- /V01: Multi-turn fine adjustment

RELATED PRODUCTS

- Installation Base or Single Mount Base Socket (model: M8BSx)
This unit must be mounted on dedicated base or socket.

GENERAL SPECIFICATIONS

- Construction:** Plug-in
- Mounting screw:** M3 screw (torque 0.3 N·m)
- Housing material:** Flame-resistant resin (black)
- Power supply:** Via the Installation Base terminals (model: M8BSx)
- Isolation:** Input to output 1 to output 2 to power
- Zero adjustment:** -2 to +2 % (front)
- Span adjustment:** 98 to 102 % (front)
- Input pulse sensing:** DC coupled (AC coupled for AC voltage pulse)

INPUT SPECIFICATIONS

- Frequency range:** 0 - 20 Hz through 20 kHz
- Pulse width (time) requirement:** Duty ratio 20 - 80 % at 100 % input
- **Dry Contact**
Sensing: Approx. 12 V DC @3 mA
ON/OFF level: \leq 200 Ω /0.5 V for ON, \geq 100 k Ω /9 V for OFF
- **DC Voltage Pulse:** Specify detecting level, amplitude and DC offset.
- Waveform:** Square or sine
- Input impedance:** 10 k Ω min.
- Input amplitude:** 2 - 50 V p-p
- Detecting level:** 2 - 10 V; $0.6 \text{ V} \leq V_H - V_L \leq 1.3 \text{ V}$
- Max. voltage between input terminals:** 50 V
- **5 V, 12 V, 24 V Pulse**
Waveform: Square or sine
Input impedance: 10 k Ω min.
Detecting H level
5 V pulse: \geq 3 V



12 V, 24 V pulse: ≥ 6 V

Detecting L level

5 V pulse: ≤ 1 V

12 V, 24 V pulse: ≤ 4 V

■ **AC Voltage Pulse:** Specify amplitude and frequency.

Waveform: Sine

Input impedance: 10 k Ω min.

Input amplitude: 0.1 - 100 V p-p

Max. voltage between input terminals: 50 V

■ **DC VOLTAGE PULSE**

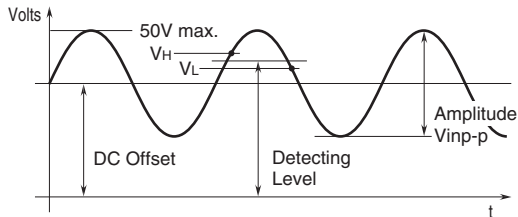

■ **AC VOLTAGE PULSE**

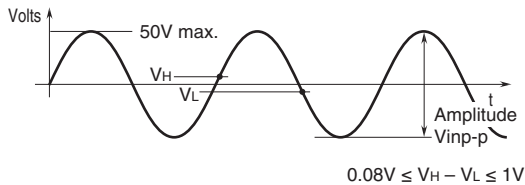

STANDARDS & APPROVALS

CE conformity:

EMC Directive (2004/108/EC)

EMI EN 61000-6-4: 2007

EMS EN 61000-6-2: 2005

INSTALLATION

Current consumption: Approx. 50 mA

Operating temperature: 0 to 55°C (32 to 131°F)

Operating humidity: 30 to 95 %RH (non-condensing)

Mounting: Installation Base (model: M8BSx)

Weight: 70 g (2.5 oz)

PERFORMANCE in percentage of span

Accuracy: ± 0.1 % (output 10 - 100 %)

Temp. coefficient: ± 0.02 %/°C (± 0.01 %/°F)

Response time: (0 - 90 %)

approx. 4 seconds for 0 - 50 Hz

approx. 3 second for 0 - 100 Hz

approx. 1 second for 0 - 200 Hz

approx. 0.4 second for 0 - 1.99 kHz

approx. 0.1 second for 0 - 2 kHz or more

Ripple: 0.2 %p-p max. with input ≥ 10 %

Line voltage effect: ± 0.1 % over voltage range

Insulation resistance: ≥ 100 M Ω with 500 V DC

Dielectric strength:

1500 V AC @1 minute (input to output 1 or output 2 or power to ground)

500 V AC @1 minute (output 1 to output 2 to power)

SWC test: ANSI/IEEE-C37.90.1-1989



DIMENSIONS unit: mm (inch)

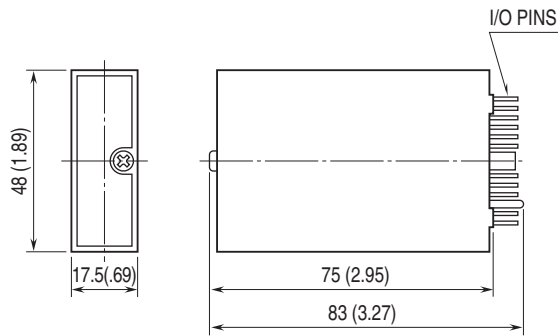

SCHEMATIC CIRCUITRY & CONNECTION DIAGRAM

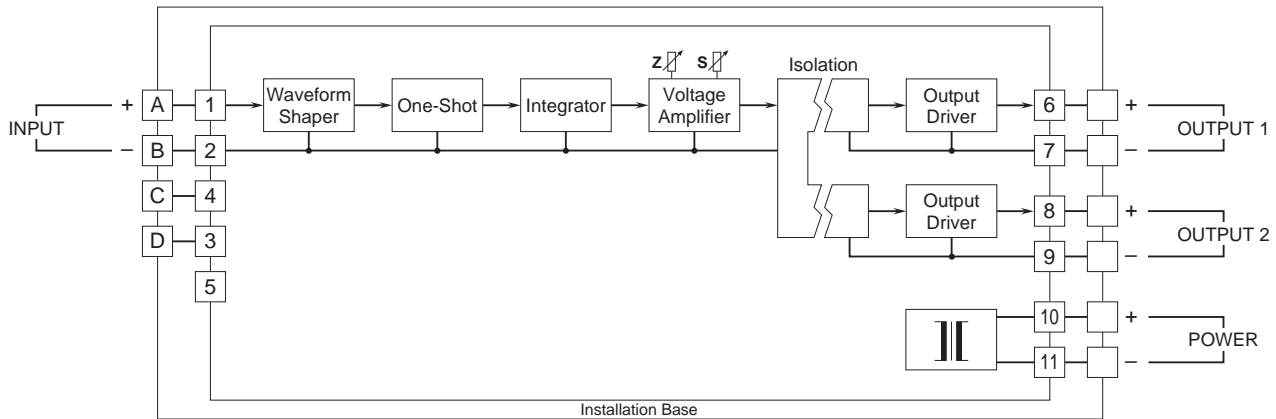

Input Connection Examples

■ Dry Contact

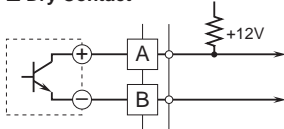

■ AC Voltage Pulse

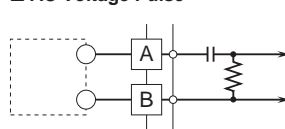

■ DC Voltage Pulse

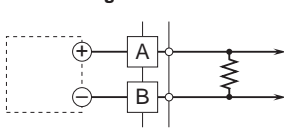

Specifications are subject to change without notice.