

## Super-mini Signal Conditioners with LCD Display M7E-UNIT Series

### TWO-WIRE TRANSMITTER ALARM

(dual or quad alarm trip)

#### Functions & Features

- Provides relay outputs at preset DC input levels
- Quad or dual trip
- Powers a 4 - 20 mA DC current loop
- Shortcircuit protection
- Applicable to smart transmitters
- Linearization or square root extraction programmable
- Front LCD display indicating values in scaled engineering unit range is used to program the module
- Adjustable deadband (hysteresis)
- Software lock
- ON delay time selectable
- Hi/Lo trip and energized/de-energized coil independently selectable for each setpoint
- Enclosed relays
- Relays can be powered by 200 V AC and 100 V DC
- High-density mounting on DIN rail

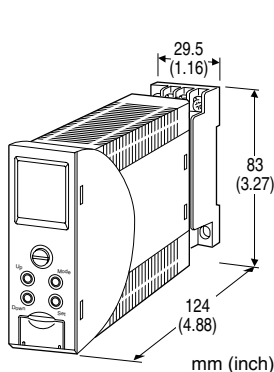

#### [1] OUTPUT

- 2: 4 points; N.O. or make contact
- 3: 4 points; N.C. or break contact
- 5: 2 points; SPDT or transfer contact

#### [2] POWER INPUT

##### AC Power

**M2:** 100 - 240 V AC (Operational voltage range 85 - 264 V, 47 - 66 Hz)

##### DC Power

**R:** 24 V DC

(Operational voltage range 24 V  $\pm$ 10 %, ripple 10 %p-p max.)

#### [3] OPTIONS (multiple selections)

##### Standards & Approvals

**blank:** Without CE

**/CE:** CE marking

##### Other Options

**blank:** none

**/Q:** Option other than the above (specify the specification)

#### SPECIFICATIONS OF OPTION: Q (multiple selections)

##### COATING (For the detail, refer to M-System's web site.)

**/C01:** Silicone coating

**/C02:** Polyurethane coating

**/C03:** Rubber coating

##### TERMINAL SCREW MATERIAL

**/S01:** Stainless steel

##### EX-FACTORY SETTING

**/SET:** Preset according to the Ordering Information Sheet

(No. ESU-7763)

### MODEL: M7EASDY-[1]-[2][3]

#### ORDERING INFORMATION

- Code number: M7EASDY-[1]-[2][3]

Specify a code from below for each [1] through [3].

(e.g. M7EASDY-2-R/CE/Q)

- Specify the specification for option code /Q (e.g. /C01/S01/SET)

#### INPUT

##### Current

4 - 20 mA DC

(Selectable within 0 - 20 mA DC)



**幸託有限公司**  
XIN TOP CORPORATION

TEL : (02)2598-1199  
FAX : (02)2596-2331

E-mail : info@xintop.com  
Website : www.xintop.com

## FACTORY DEFAULT SETTING

|                         |                                                                |
|-------------------------|----------------------------------------------------------------|
| INPUT CALIBRATION       | 4 – 20 mA DC                                                   |
| LOW CUT POINT           | 0.00                                                           |
| MOVING AVERAGE          | NONE                                                           |
| SCALING RANGE           | 0.0 – 100.0                                                    |
| DECIMAL POINT           | XXX.X                                                          |
| SCALING UNIT            | °C                                                             |
| LINEARIZATION           | Linear                                                         |
| L1 ALARM VALUE          | 20.0                                                           |
| L1 ALARM TRIP OPERATION | Lo alarm trip                                                  |
| L1 ALARM HYSTERESIS     | 1.0                                                            |
| L1 ALARM COIL AT ALARM  | Coil energized                                                 |
| L2 ALARM VALUE          | 80.0 (2 point alarm)<br>30.0 (4 point alarm)                   |
| L2 ALARM TRIP OPERATION | Hi alarm trip (2 point alarm)<br>Lo alarm trip (4 point alarm) |
| L2 ALARM HYSTERESIS     | 1.0                                                            |
| L2 ALARM COIL AT ALARM  | Coil energized                                                 |
| L3 ALARM VALUE          | 70.0                                                           |
| L3 ALARM TRIP OPERATION | Hi alarm trip                                                  |
| L3 ALARM HYSTERESIS     | 1.0                                                            |
| L3 ALARM COIL AT ALARM  | Coil energized                                                 |
| L4 ALARM VALUE          | 80.0                                                           |
| L4 ALARM TRIP OPERATION | Hi alarm trip                                                  |
| L4 ALARM HYSTERESIS     | 1.0                                                            |
| L4 ALARM COIL AT ALARM  | Coil energized                                                 |
| POWER ON DELAY TIMER    | 5                                                              |
| ALARM ON DELAY TIMER    | 0                                                              |
| LATCHING                | Invalid                                                        |
| LCD CONTRAST            | 50                                                             |
| LCD BACK LIGHT          | Off Timer                                                      |
| LCD BACK LIGHT OFF TIME | 10                                                             |

## RELATED PRODUCTS

- PC configurator software (model: M7CFG)  
Downloadable at M-System's web site.  
A dedicated cable is required to connect the module to the PC. Please refer to the internet software download site or the users manual for the PC configurator for applicable cable types.

## GENERAL SPECIFICATIONS

- Construction:** Plug-in  
**Connection:** M3 screw terminals (torque 0.8 N·m)  
**Screw terminal:** Chromated steel (standard) or stainless steel  
**Housing material:** Flame-resistant resin (black)  
**Isolation:** Input to output to power  
**Programming:** Front control buttons or PC software  
**Programmable parameters:**
- Input range
  - Input fine adjustments
  - Moving average (None, 4, 8, 16 or 32 samples)
  - Scale Range: -9999 to +9999
- Unit: User specific unit programmable.

- Decimal point position
- Linearization (linear, square root, user table: 128 points)
- Alarm output (L1...L4 independently)
  - Setpoint (scaled value)
  - Trip action (Hi or Lo)
  - Deadband (hysteresis) (scaled value)
  - Relay coil (energized or de-energized)
- Power ON delay time (0 to 99 sec.)
- Alarm ON delay time (0 to 999 sec.)
- Latching or not
- LCD Contrast
  - Back Light (On, Off, Off timer)

## LCD DISPLAY

- Display functions:** Displays and sets measured range, engineering unit, alarm operation  
**Effective visual area:** Approx. 15.6 × 18.9 mm (0.61" × 0.74")  
**Number of pixels:** 68 × 95 (horizontal × vertical)  
**Character color:** Black  
**Backlight:** LED (orange in normal status, red when an alarm is tripped.)  
**Backlight life:** Approx. 50 000 hours  
 (Expected time for the LCD brightness to be reduced by half when the LCD is used continuously in 50 % brightness in 25°C)  
**LCD type:** Transreflective FSTN  
**Display range:** -9999 to +9999  
**Decimal point position:** Selectable  
**Display rate:** 150 msec.

## SUPPLY OUTPUT

- **SUPPLY OUTPUT (across the terminals 1 - 2)**
- Output voltage:** 24 - 28 V DC with no load  
19 V DC minimum at 20 mA
- Current rating:** ≤ 22 mA DC
- Permissible load resistance:**  
 $LR (\Omega) \leq (19 - \text{Min. Operational Voltage})V \div 0.02 A$
- **Shortcircuit Protection**
- Current limited:** 26 - 35 mA
- Protected time duration:** No limit

## INPUT SPECIFICATIONS

- **Input Signal:** Input resistor incorporated
- Maximum range:** 0 - 20 mA DC
- Ex-factory setting:** 4 - 20 mA DC
- Minimum span:** 2 mA
- Offset:** Lower range can be any specific value within the maximum range provided that the minimum span is maintained.



## OUTPUT SPECIFICATIONS

### ■ Quad Alarm

**Relay rating:** 100 V AC @ 1 A ( $\cos \phi = 1$ )  
 120 V AC @ 1 A ( $\cos \phi = 1$ )  
 240 V AC @ 0.5 A ( $\cos \phi = 1$ )  
 30 V DC @ 1 A (resistive load)

**Maximum switching voltage:** 250 V AC or 125 V DC  
 (Limited to the max. voltage 150 V AC or to the use for Measurement Category I in order to conform with EC Directive)

**Maximum switching power:** 120 VA or 30 W

**Minimum load:** 5 V DC @ 10 mA

**Mechanical life:**  $5 \times 10^7$  cycles

### ■ DUAL ALARM

**Relay rating:** 100 V AC @ 4 A ( $\cos \phi = 1$ )  
 120 V AC @ 4 A ( $\cos \phi = 1$ )  
 240 V AC @ 2 A ( $\cos \phi = 1$ )  
 30 V DC @ 4 A (resistive load)

**Maximum switching voltage:** 250 V AC or 125 V DC  
 (Limited to the max. voltage 150 V AC or to the use for Measurement Category I in order to conform with EC Directive)

**Maximum switching power:** 480 VA or 150 W

**Minimum load:** 5 V DC @ 10 mA

**Mechanical life:**  $5 \times 10^7$  cycles

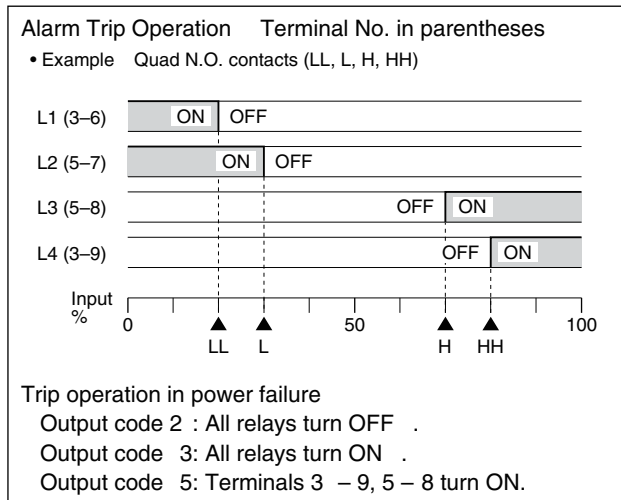

## LINEARIZATION

### ■ Linearization Types

**Linear:** No linearization

**Square root:** The input is square root extracted.

**User table**

**Calibration points:** Max. 128 points; the input % and linearized value in scaling are specified in pairs.

**Selectable range:** -7.5 to +107.5 % as input %; -9999 to +9999 as linearized values

■ **Low-end Cutout:** Low-end cutout (Low Cut) point

selectable within the range of 0 to 100 %.

With the linear or user table output type, the output signal is forcibly set to 0 % for the input lower than the low-cut point. With the square root extraction, the output signal is linear to the input when the latter is lower than the low-cut point.

### • Linear or User Table

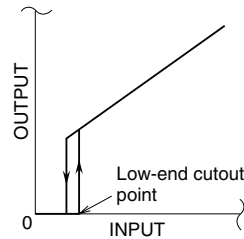

### • Square Root

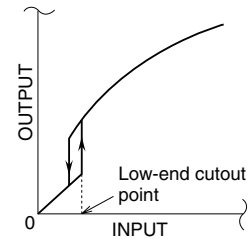

## INSTALLATION

### Power consumption

• **AC:** Approx. 5 VA at 100 V  
 Approx. 7 VA at 200 V  
 Approx. 8.5 VA at 264 V  
 • **DC:** Approx. 3 W

**Operating temperature:** -5 to +55°C (23 to 131°F)

**Operating humidity:** 30 to 90 %RH (non-condensing)

**Mounting:** Surface or DIN rail

With 4-point alarm type, leave extra 1-unit space on both sides of the unit if all 4 relay coils are to be energized in normal conditions.

**Weight:** 200 g (0.44 lb)

## PERFORMANCE in percentage of FS input

### Setpoint accuracy (trip point accuracy):

$\pm(0.1 \% \text{ of FS} + 1 \text{ digit})$  (gain  $\leq 1$ )

$\pm(0.1 \% \times \text{gain of FS} + 1 \text{ digit})$  (gain  $> 1$ )

**Display accuracy:**  $\pm(0.1 \% \text{ of FS} + 1 \text{ digit})$

**Temp. coefficient:**  $\pm 0.015 \% / ^\circ\text{C}$  ( $\pm 0.008 \% / ^\circ\text{F}$ )

**Response time:**  $\leq 0.5 \text{ sec.}$  (0 - 100 % at 90 % setpoint)

**Line voltage effect:**  $\pm 0.1 \%$  over voltage range

**Insulation resistance:**  $\geq 100 \text{ M}\Omega$  with 500 V DC

**Dielectric strength:** 2000 V AC @1 minute (input to output to power to ground)

## STANDARDS & APPROVALS

### CE conformity:

EMC Directive (2004/108/EC)

EMI EN 61000-6-4: 2007/A1: 2011

EMS EN 61000-6-2: 2005

Low Voltage Directive (2006/95/EC)

EN 61010-1: 2010

Measurement Category II (output)

Installation Category II (power)



# MODEL: M7EASDY

Pollution Degree 2

Input or output to power: Reinforced insulation (300 V)

Input to output: Basic insulation (300 V)

(When 150 V AC max. load voltage or measurement category I, applicable as reinforced insulation)

## EXTERNAL VIEW

Refer to the instruction manual for the setting procedure.

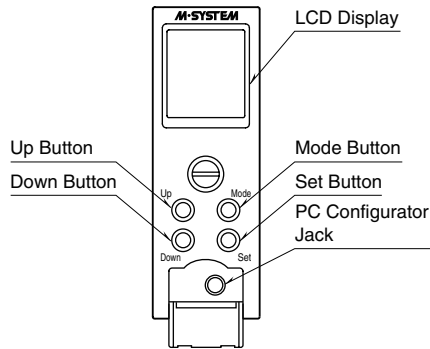

## EXTERNAL DIMENSIONS & TERMINAL ASSIGNMENTS unit: mm (inch)

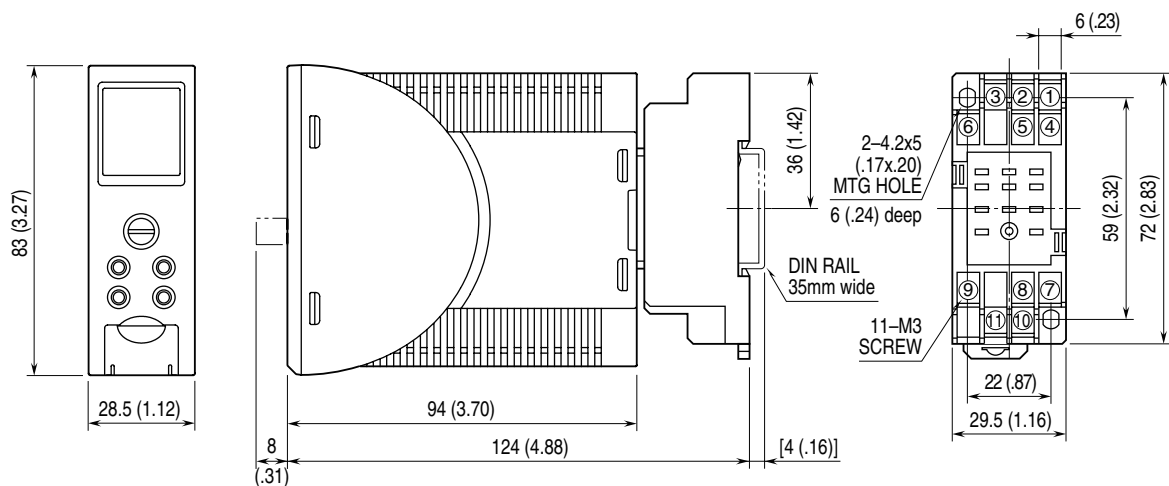

• When mounting, no extra space is needed between units.



**幸託有限公司**  
XIN TOP CORPORATION

TEL : (02)2598-1199  
FAX : (02)2596-2331

E-mail : [info@xintop.com](mailto:info@xintop.com)  
Website : [www.xintop.com](http://www.xintop.com)

## SCHEMATIC CIRCUITRY & CONNECTION DIAGRAM

### ■ OUTPUT CODE 2: N.O. Relay

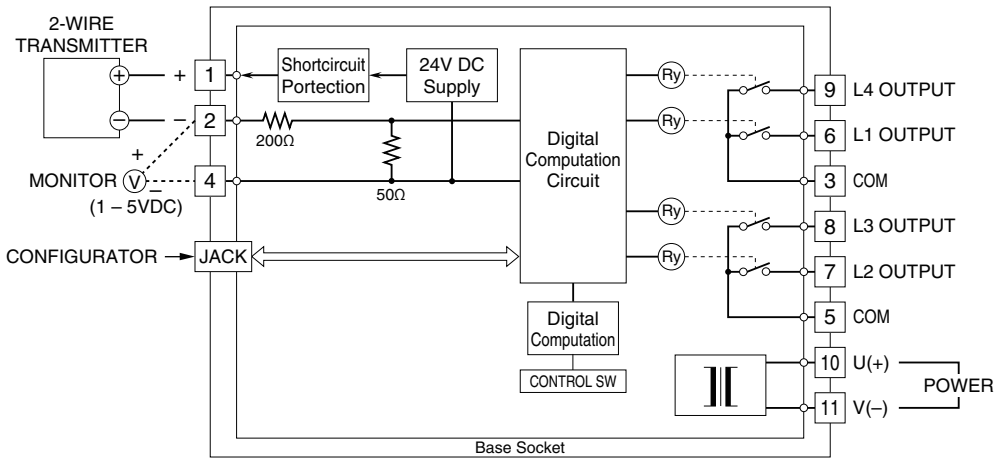

### ■ OUTPUT CODE 3: N.C. Relay

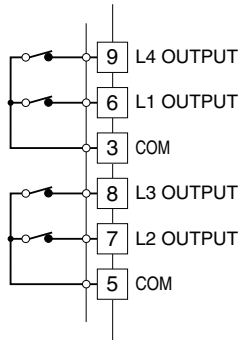

### ■ OUTPUT CODE 5: SPDT Relay

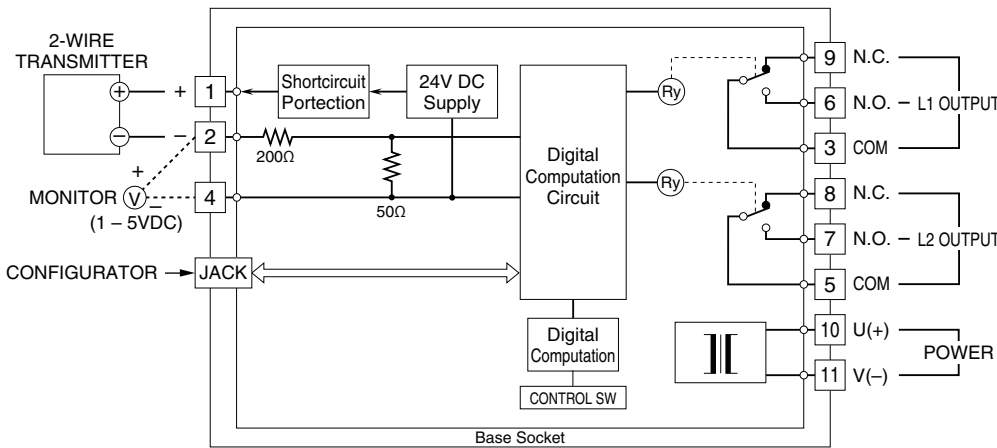

#### ■ When 24V DC is Not Used

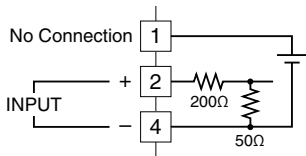

#### ■ Relay Protection • AC Powered

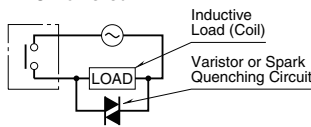

#### • DC Powered

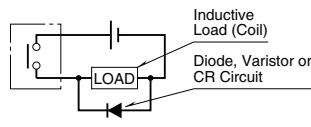

Specifications are subject to change without notice.