

Super-mini Terminal Block Signal Conditioners M5-UNIT

PT TRANSMITTER

Functions & Features

- Converts an alternating voltage from a potential (voltage) transformer into a standard process signal
- True RMS sensing
- High-density mounting
- Power LED

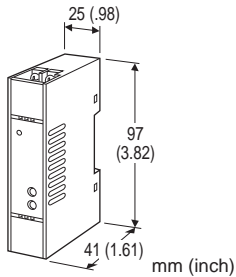

MODEL: M5PT-[1][2]-[3][4]

ORDERING INFORMATION

Specify a code from below for each [1] through [4].

- Code number: M5PT-[1][2]-[3][4]
(e.g. M5PT-14W-R/Q)

Specify variables.

- Special output range (For codes Z & 0)
- Specify the specification for option code /Q
(e.g. /C01)

[1] INPUT

Voltage

- 1: 0 - 110 V AC
- 2: 0 - 220 V AC
- 5: 0 - 150 V AC

[2] OUTPUT

Current

- A: 4 - 20 mA DC (Load resistance 550 Ω max.)
- Z: Specify current (See OUTPUT SPECIFICATIONS)

Voltage

- 4: 0 - 10 V DC (Load resistance 1000 Ω min.)
- 5: 0 - 5 V DC (Load resistance 500 Ω min.)
- 6: 1 - 5 V DC (Load resistance 500 Ω min.)
- 4W: -10 - +10 V DC (Load resistance 8000 Ω min.)
- 5W: -5 - +5 V DC (Load resistance 4000 Ω min.)
- 0: Specify voltage (See OUTPUT SPECIFICATIONS)

[3] POWER INPUT

AC Power

M: 85 - 264 V AC (Operational voltage range 85 - 264 V, 47 - 66 Hz)

DC Power

R: 24 V DC
(Operational voltage range 24 V ±10 %, ripple 10 %p-p max.)

[4] OPTIONS

blank: none

/Q: With options (specify the specification)

SPECIFICATIONS OF OPTION: Q

COATING (For the detail, refer to M-System's web site.)

/C01: Silicone coating

/C02: Polyurethane coating

/C03: Rubber coating

GENERAL SPECIFICATIONS

Construction: Terminal block

Connection: M3.5 screw terminals (torque 0.8 N·m)

Screw terminal: Nickel-plated steel

Housing material: Flame-resistant resin (black)

Isolation: Input to output to power

Input waveform

RMS sensing: Up to 15 % of 3rd harmonic content

Zero adjustment: -2 to +2 % (front)

Span adjustment: 98 to 102 % (front)

Power LED: Green light turns on when the power is supplied.

INPUT SPECIFICATIONS

Frequency: 50 or 60 Hz

Input burden: 0.5 VA max.

Overload capacity: 200 % of rating for 1 min., 120 % continuous

Operational range: 5 - 120 % of rating

OUTPUT SPECIFICATIONS

■ **DC Current:** 0 - 20 mA DC

Minimum span: 1 mA

Offset: Max. 1.5 times span

Load resistance: Output drive 11 V max.

■ **DC Voltage:** 0 - 10 V DC

Minimum span: 1 V

Offset: Max. 1.5 times span

Load resistance: Output drive 10 mA max.; at ≥ 1 V



INSTALLATION

Power Consumption

•AC:

Approx. 2 VA at 100 V

Approx. 3 VA at 200 V

Approx. 3 VA at 264 V

•DC: Approx. 2 W

Operating temperature: -5 to +55°C (23 to 131°F)

Operating humidity: 0 to 90 %RH (non-condensing)

Mounting: DIN rail

Weight: 80 g (2.8 oz)

PERFORMANCE in percentage of span

Accuracy: $\pm 0.3\%$ with input 5 - 100 %

(Input 10 - 100 % for the output codes 4W and 5W)

Temp. coefficient: $\pm 0.02\%$ /°C ($\pm 0.01\%$ /°F)

Response time: ≤ 0.5 sec. (0 - 90 %)

Ripple: 0.5 %p-p max.

Line voltage effect: $\pm 0.1\%$ over voltage range

Insulation resistance: $\geq 100\text{ M}\Omega$ with 500 V DC

Dielectric strength (input to output to power to ground)

DC powered: 2000 V AC @1 minute

AC powered: 1500 V AC @1 minute

FRONT VIEW

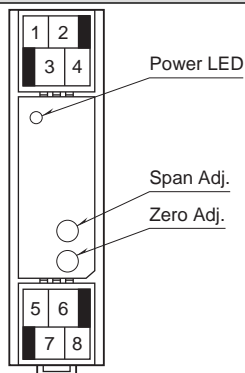

DIMENSIONS unit: mm (inch)

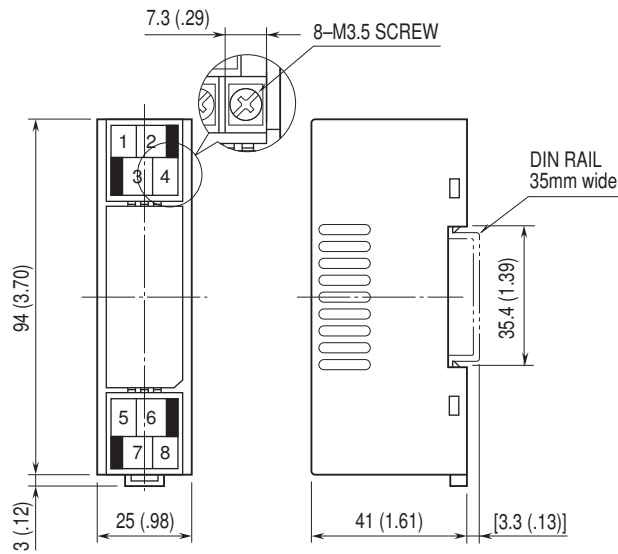

• When mounting, no extra space is needed between units.

SCHEMATIC CIRCUITRY & CONNECTION DIAGRAM

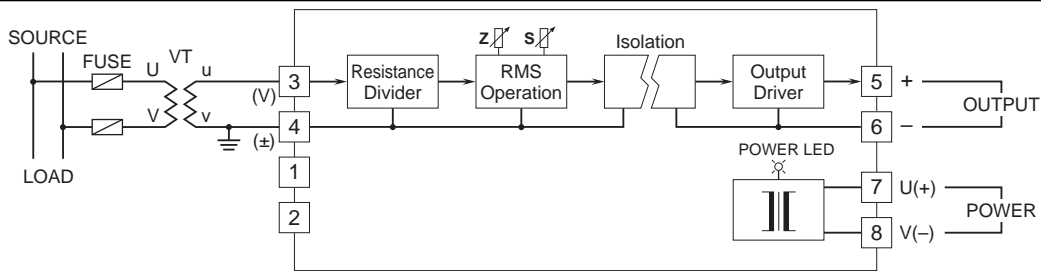

Specifications are subject to change without notice.