

Super-space-saving Signal Conditioners M3S-UNIT Series

THERMOCOUPLE TRANSMITTER

(PC programmable)

Functions & Features

- Accepts a thermocouple input and provides an isolated, linearized DC signal
- Cold junction compensation, linearization and burnout protection
- PC programmable
- Universal AC/DC power input
- High-density mounting
- Power and status indicator LED
- CE marking

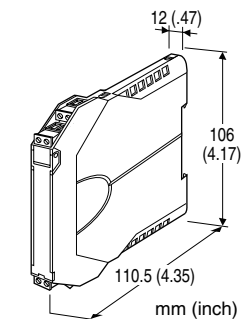

MODEL: M3SXT-[1][2]-[3]

ORDERING INFORMATION

- Code number: M3SXT-[1][2]-[3]
- Specify a code from below for each [1] through [3].
(e.g. M3SXT-2Z1-R)
- Temperature range (e.g. 0 - 1000°C)
 - Output range (e.g. 4 - 20 mA DC)

[1] INPUT THERMOCOUPLE

- 1: (PR)
 - 2: K (CA)
 - 3: E (CRC)
 - 4: J (IC)
 - 5: T (CC)
 - 6: B (RH)
 - 7: R
 - 8: S
 - N: N
- 0: Specify (Please provide a emf table.)
(Configurator software is used to change the input type and precise range.)

[2] OUTPUT

Current

Z1: Range 0 - 20 mA DC

Voltage

V2: Range -10 - +10 V DC

V3: Range -5 - +5 V DC

(Configurator software is used to change output over the described range of the selected suffix code.

For changing between suffix codes, set the Output Range Selector on the side of unit before software adjustment.)

[3] POWER INPUT

AC Power

M2: 100 - 240 V AC (Operational voltage range 90 - 264 V, 47 - 66 Hz)

DC Power

R: 24 V DC

(Operational voltage range 24 V \pm 10 %, ripple 10 %p-p max.)

Universal

AD: 100 - 240 V AC / 24 - 240 V DC (universal)

(Operational voltage range 90 - 264 V AC, 47 - 66 Hz / 21.6 - 264 V DC, ripple 10 %p-p max.)

RELATED PRODUCTS

- PC configurator software (model: M3SCFG)
Downloadable at M-System's web site.
A dedicated cable is required to connect the module to the PC. Please refer to the internet software download site or the users manual for the PC configurator for applicable cable types.

GENERAL SPECIFICATIONS

Construction: Small-sized front terminal structure

Connection: Removable terminal block

Applicable wire size: 0.2 to 2.5 mm²

Housing material: Flame-resistant resin (gray)

Isolation: Input to output to power

Overrange output: -2 - +102 %

(Negative current output is not available.)

Zero adjustment: -2 to +2 % (PC programming)

Span adjustment: 98 to 102 % (PC programming)

Burnout: Upscale standard; downscale or no burnout optional by programming

Linearization: Standard

Cold Junction Compensation: CJC sensor incorporated

Power LED: Green light turns on when the power is supplied.

Status indicator LED: Orange LED; Flashing patterns indicate different operating status of the transmitter.

Programming: Downloaded from PC; input type and range, output type and range, zero and span, burnout type, user's linearization table (max. 300 points, input emf specified)



within ± 1000 mV), etc.

Refer to the instruction manual for details.

Configurator connection: 2.5 dia. miniature jack;
RS-232-C level

INPUT SPECIFICATIONS

Input resistance: 1 M Ω minimum

Burnout sensing: 0.1 μ A

Factory setting:

1: PR 0 - 1600°C

2: K 0 - 1000°C

3: E 0 - 500°C

4: J 0 - 500°C

5: T 0 - 300°C

6: B 500 - 1600°C

7: R 500 - 1600°C

8: S 0 - 1600°C

N: N 0 - 1000°C

OUTPUT SPECIFICATIONS

• DC Current

Output range: 0 - 20 mA DC

Conformance range: 0 - 20.4 mA DC

Minimum span: 1 mA

Offset: Lower range can be any specific value within the output range provided that the minimum span is maintained.

Load resistance: Output drive 11 V max.

(e.g. 4 - 20 mA: 550 Ω [11 V/20 mA])

If not specified, the output range is 4 - 20 mA DC.

• DC VOLTAGE

Code V2 (wide spans)

Output range: -10 - +10 V DC

Conformance range: -10.4 - +10.4 V DC

Minimum span: 1 V

Code V3 (narrow spans)

Output range: -5 - +5 V DC

Conformance range: -5.2 - +5.2 V DC

Minimum span: 0.5 V

Offset: Lower range can be any specific value within the output range provided that the minimum span is maintained.

Load resistance: Output drive 1 mA max.

(e.g. 1 - 5 V: 5000 Ω [5 V/1 mA])

If not specified, the output range is shown below.

V2: 0 - 10 V DC

V3: 1 - 5 V DC

INSTALLATION

Power Consumption

•AC:

Approx. 2 VA at 100 V

Approx. 3 VA at 200 V

Approx. 4 VA at 264 V

•DC:

R: Approx. 0.5 W

AD: Approx. 1 W

Operating temperature: -10 to +55°C (14 to 131°F)

Operating humidity: 30 to 90 %RH (non-condensing)

Mounting: DIN rail

Weight: 85 g (3.0 oz)

PERFORMANCE

Overall accuracy: Input accuracy + output accuracy

Input accuracy: Accuracy + Cold Junction Compensation
Error 1°C (1.8°F)

Output accuracy: Max. Output Range / Span \times ± 0.04 %

Cold junction compensation error:

$\pm 1^\circ\text{C}$ max. at 25 $\pm 10^\circ\text{C}$

$\pm 1.8^\circ\text{F}$ max. at 77 $\pm 18^\circ\text{F}$

Temp. coefficient: ± 0.015 %/°C (± 0.008 %/°F) of max. span

Response time: ≤ 0.5 sec. (0 - 90 %)

Burnout response: ≤ 10 sec.

Line voltage effect: ± 0.1 % over voltage range

Insulation resistance: ≥ 100 M Ω with 500 V DC

Dielectric strength: 2000 V AC @1 minute (input to output to power to ground)

CALCULATION EXAMPLES OF OVERALL ACCURACY

Input: K thermocouple, 0 - 1000°C, Output: 4 - 20 mA DC

Absolute value accuracy (Table 1): 0.25°C

CJC error (1°C) added: 1.25°C

➡ Input accuracy = 1.25°C / 1000°C \times 100 = 0.125 %

Output span: 16 mA (20 - 4)

➡ Output accuracy = 20 mA / 16 mA \times 0.04 = 0.05 %

➡ Overall accuracy including CJC error = 0.125 + 0.05 = ± 0.18 % of span

STANDARDS & APPROVALS

CE conformity:

EMC Directive (2004/108/EC)

EMI EN 61000-6-4: 2007

EMS EN 61000-6-2: 2005

Low Voltage Directive (2006/95/EC)

EN 61010-1: 2001

Installation Category II

Pollution Degree 2

Input or output to power: Reinforced insulation (300 V)

Input to output: Basic insulation (300 V)



EXTERNAL VIEW

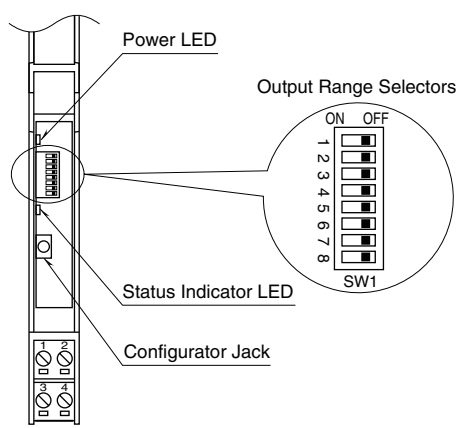

INPUT TYPE, RANGE & ACCURACY

Table 1.

THERMOCOUPLE	°C				°F			
	MIN. SPAN	MAXIMUM RANGE	CONFORMANCE RANGE	ACCURACY	MIN. SPAN	MAXIMUM RANGE	CONFORMANCE RANGE	ACCURACY
(PR)	20	0 to 1760	0 to 1760	±1.00	36	32 to 3200	32 to 3200	±1.80
K (CA)	20	-270 to +1370	-150 to +1370	±0.25	36	-454 to +2498	-238 to +2498	±0.45
E (CRC)	20	-270 to +1000	-170 to +1000	±0.20	36	-454 to +1832	-274 to +1832	±0.36
J (IC)	20	-210 to +1200	-180 to +1200	±0.25	36	-346 to +2192	-292 to +2192	±0.45
T (CC)	20	-270 to +400	-170 to +400	±0.25	36	-454 to +752	-274 to +752	±0.45
B (RH)	20	100 to 1820	400 to 1760	±0.75	36	212 to 3308	752 to 3200	±1.35
R	20	-50 to +1760	200 to 1760	±0.50	36	-58 to +3200	392 to 3200	±0.90
S	20	-50 to +1760	0 to 1760	±0.50	36	-58 to +3200	32 to 3200	±0.90
N	20	-270 to +1300	-130 to +1300	±0.30	36	-454 to +2372	-202 to +2372	±0.54

EXTERNAL DIMENSIONS & TERMINAL ASSIGNMENTS unit: mm (inch)

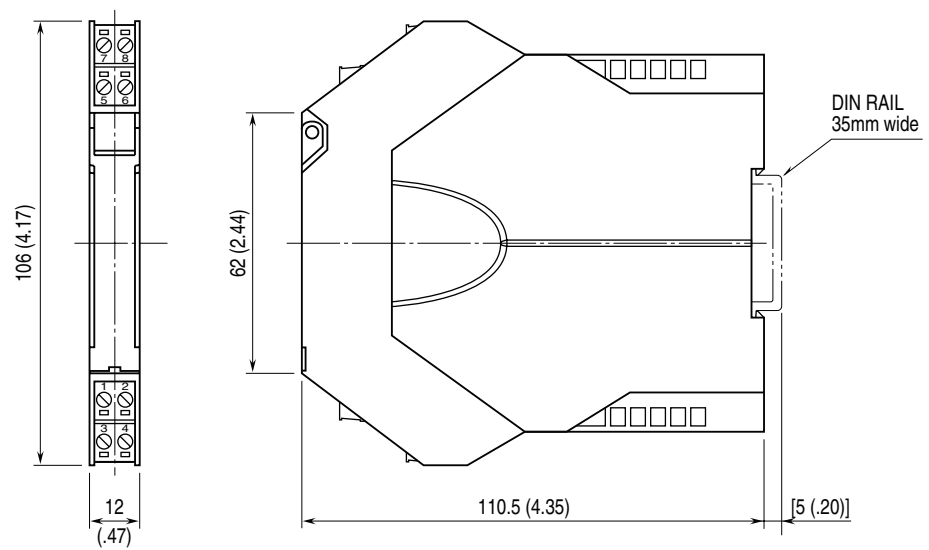

• When mounting, no extra space is needed between units.



SCHEMATIC CIRCUITRY & CONNECTION DIAGRAM

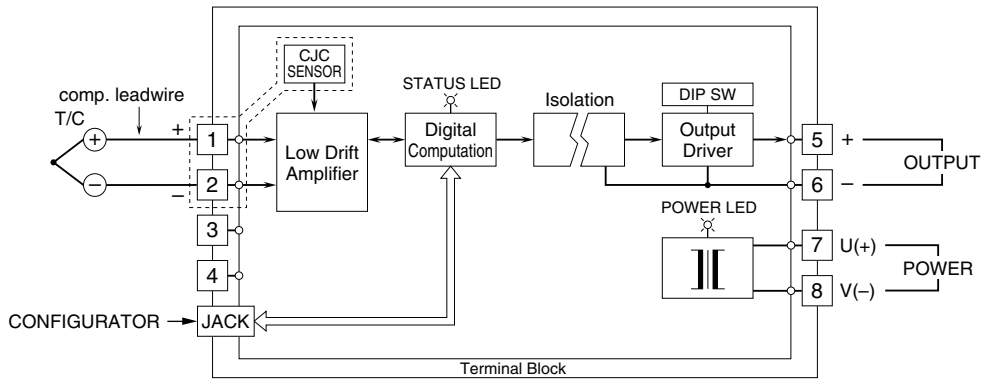

Specifications are subject to change without notice.

