

**Super-space-saving Signal Conditioners**  
**M3S-UNIT Series**

**POTENTIOMETER TRANSMITTER**

(PC programmable)

**Functions & Features**

- Provides a DC output proportional to a potentiometer or slidewire position input
- Linearization and burnout protection
- PC programmable
- Universal AC/DC power input
- High-density mounting
- Power and status indicator LED
- CE marking

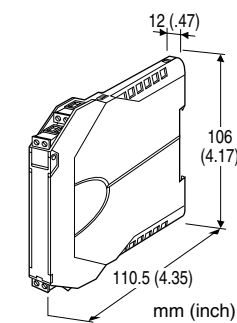

**MODEL: M3SXM-1[1]-[2]**

**ORDERING INFORMATION**

- Code number: M3SXM-1[1]-[2]
- Specify a code from below for each [1], [2]. (e.g. M3SXM-1Z1-R)
- Output range (e.g. 4 - 20 mA DC)

**INPUT**

**1:** Total resistance 100 - 5000 Ω  
 (Configurator software is used to change the input range.)

**[1] OUTPUT**

**Current**

**Z1:** Range 0 - 20 mA DC

**Voltage**

**V2:** Range -10 - +10 V DC

**V3:** Range -5 - +5 V DC

(Configurator software is used to change output over the described range of the selected suffix code.  
 For changing between suffix codes, set the Output Range Selector on the side of unit before software adjustment.)

**[2] POWER INPUT**

**AC Power**

**M2:** 100 - 240 V AC (Operational voltage range 90 - 264 V, 47 - 66 Hz)

**DC Power**

**R:** 24 V DC

(Operational voltage range 24 V ±10 %, ripple 10 %p-p max.)

**Universal**

**AD:** 100 - 240 V AC / 24 - 240 V DC (universal)

(Operational voltage range 90 - 264 V AC, 47 - 66 Hz / 21.6 - 264 V DC, ripple 10 %p-p max.)

**RELATED PRODUCTS**

- PC configurator software (model: M3SCFG)  
 Downloadable at M-System's web site.  
 A dedicated cable is required to connect the module to the PC. Please refer to the internet software download site or the users manual for the PC configurator for applicable cable types.

**GENERAL SPECIFICATIONS**

**Construction:** Small-sized front terminal structure

**Connection:** Removable terminal block

**Applicable wire size:** 0.2 to 2.5 mm<sup>2</sup>

**Housing material:** Flame-resistant resin (gray)

**Isolation:** Input to output to power

**Overrange output:** -2 - +102 %

(Negative current output is not available.)

**Zero adjustment:** -2 to +2 % (PC programming)

**Span adjustment:** 98 to 102 % (PC programming)

**Burnout:** Upscale standard; downscale or no burnout optional by programming

**Power LED:** Green light turns on when the power is supplied.

**Status indicator LED:** Orange LED; Flashing patterns indicate different operating status of the transmitter.

**Programming:** Downloaded from PC; input type and range, output type and range, zero and span, burnout type, user's linearization table (max. 101 points, specified within -2 to +102 % for both input and output), etc.

Refer to the instruction manual for details.

**Configurator connection:** 2.5 dia. miniature jack; RS-232-C level

**INPUT SPECIFICATIONS**

**Sensing current:** ≤ 0.15 mA

**Minimum span of each range**

0 - 100 Ω : 10 Ω

0 - 300 Ω : 30 Ω

0 - 600 Ω : 60 Ω

0 - 1200 Ω : 120 Ω

0 - 2500 Ω : 250 Ω



0 - 5000 Ω : 500 Ω

If not specified, the input range is 0 - 1200 Ω.

## OUTPUT SPECIFICATIONS

### • DC Current

**Output range:** 0 - 20 mA DC

**Conformance range:** 0 - 20.4 mA DC

**Minimum span:** 1 mA

**Offset:** Lower range can be any specific value within the output range provided that the minimum span is maintained.

**Load resistance:** Output drive 11 V max.

(e.g. 4 - 20 mA: 550 Ω [11 V/20 mA])

If not specified, the output range is 4 - 20 mA DC.

### • DC VOLTAGE

**Code V2 (wide spans)**

**Output range:** -10 - +10 V DC

**Conformance range:** -10.4 - +10.4 V DC

**Minimum span:** 1 V

**Code V3 (narrow spans)**

**Output range:** -5 - +5 V DC

**Conformance range:** -5.2 - +5.2 V DC

**Minimum span:** 0.5 V

**Offset:** Lower range can be any specific value within the output range provided that the minimum span is maintained.

**Load resistance:** Output drive 1 mA max.

(e.g. 1 - 5 V: 5000 Ω [5 V/1 mA])

If not specified, the output range is shown below.

V2: 0 - 10 V DC

V3: 1 - 5 V DC

## INSTALLATION

### Power Consumption

#### •AC:

Approx. 2 VA at 100 V

Approx. 3 VA at 200 V

Approx. 4 VA at 264 V

#### •DC:

R: Approx. 0.5 W

AD: Approx. 1 W

**Operating temperature:** -10 to +55°C (14 to 131°F)

**Operating humidity:** 30 to 90 %RH (non-condensing)

**Mounting:** DIN rail

**Weight:** 85 g (3.0 oz)

## PERFORMANCE in percentage of span

**Accuracy:** Input accuracy + output accuracy

(Inversely proportional to the span.)

**Input accuracy:** (% of range)

0 - 100 Ω : ±0.05 (%)

0 - 300 Ω : ±0.05

0 - 600 Ω : ±0.03

0 - 1200 Ω : ±0.03

0 - 2500 Ω : ±0.01

0 - 5000 Ω : ±0.01

**Output accuracy:** ±0.04 % of max. output range

**Temp. coefficient:** ±0.015 %/°C (±0.008 %/°F) of max. span

**Response time:** ≤ 1 sec. (0 - 90 %)

**Burnout response:** ≤ 10 sec.

**Line voltage effect:** ±0.1 % over voltage range

**Insulation resistance:** ≥ 100 MΩ with 500 V DC

**Dielectric strength:** 2000 V AC @1 minute (input to output to power to ground)

## CALCULATION EXAMPLES OF OVERALL ACCURACY

[Example] Total Resistance 0 - 1200 Ω, Input Range 250 - 750 Ω, Output Type -5 - +5 V, Output Range 1 - 5 V

Max. Input Range (1200 Ω) / Span (500 Ω) × 0.03 % +

Max. Output Range (10 V) / Span (4V) × 0.04 % = 0.17 %

## STANDARDS & APPROVALS

### CE conformity:

EMC Directive (2004/108/EC)

EMI EN 61000-6-4: 2007

EMS EN 61000-6-2: 2005

Low Voltage Directive (2006/95/EC)

EN 61010-1: 2001

Installation Category II

Pollution Degree 2

Input or output to power: Reinforced insulation (300 V)

Input to output: Basic insulation (300 V)



幸託有限公司

XIN TOP CORPORATION

TEL : (02)2598-1199

FAX : (02)2596-2331

E-mail : info@xintop.com

Website : www.xintop.com

**EXTERNAL VIEW**

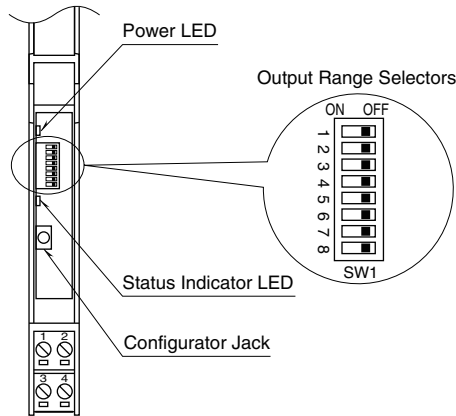

**EXTERNAL DIMENSIONS & TERMINAL ASSIGNMENTS unit: mm (inch)**

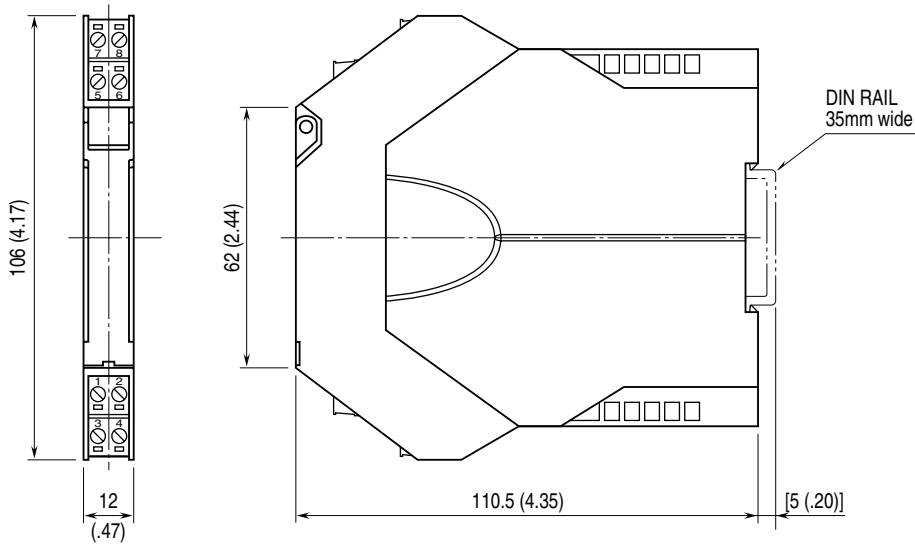

• When mounting, no extra space is needed between units.

**SCHEMATIC CIRCUITRY & CONNECTION DIAGRAM**

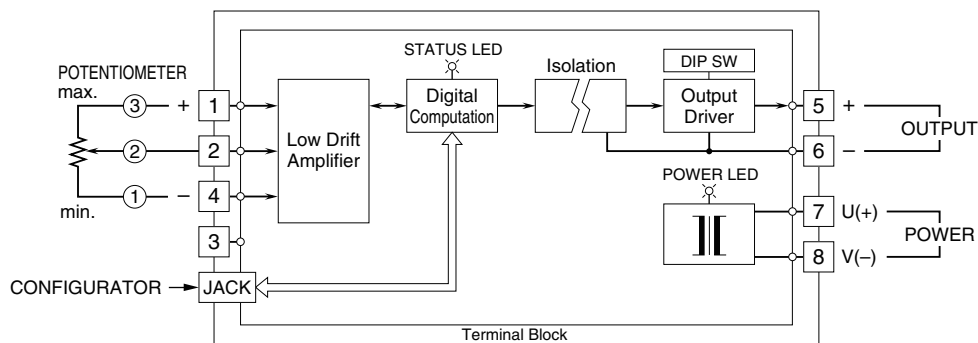

Specifications are subject to change without notice.

