

Power Transducer Series LT-UNIT

WATT TRANSDUCER

Functions & Features

- Provides a DC output signal and a pulse totalizer signal in proportion to AC active power
- Convenient pulse unit output (Wh×10ⁿ)
- Measuring bidirectional power flow
- DC output containing little ripple is ideal for computer input
- "Time division multiplication" method accepts distorted waveforms
- Isolation up to 2000 V AC
- High-density mounting
- Conforms to IEC 60688

Typical Applications

- Centralized monitoring and control of power management system in a manufacturing facility or building
- SCR - Silicon Controlled Rectifier

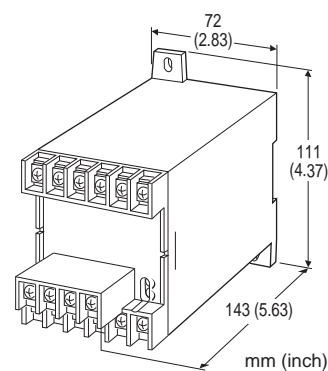

MODEL: LTWT-[1][2][3][4][5]-[6][7]

ORDERING INFORMATION

- Code number: LTWT-[1][2][3][4][5]-[6][7]
- Specify a code from below for each [1] through [7]. Use Ordering Information Sheet (No. ESU-3355). (e.g. LTWT-115A2-R/T)
- Special output range (For codes Z & 0)

How to determine Pulse Unit

[Example]

3-phase / 3-wire, VT 3300/110 V, CT 250/5 A, calibration range 750 W

$$10 \text{ [kWh/pulse]} \div ((3300 \div 110) \times (250 \div 5))$$

$$= 6.666 \times 10^{-3} \text{ [kWh/pulse]}$$

$$= 6.666 \text{ [Wh/pulse]}$$

Check that the required pulse unit is within the available frequency range, 0.006 - 3.12 Hz.

$$\begin{aligned} \text{Input Range [W]} &\div (\text{Calculated Pulse} \times 3600 \text{ [s]}) \\ &= 750 \div (6.666 \times 3600) \\ &= 0.03125 \text{ [Hz]} \end{aligned}$$

[1] CONFIGURATION

- 1: 3-phase / 3-wire
- 2: Single-phase / 2-wire
- 3: Single-phase / 3-wire
- 4: 3-phase / 4-wire

[2] VT INPUT (unbalanced load)

For 3-phase / 4-wire, phase voltages (e.g. 110 V / $\sqrt{3}$) are used.

- 1: 100, 110, 115, 120 V AC
(Not selectable for single-phase / 3-wire system.)
 - 2: 190, 200, 210, 220, 230, 240 V AC
(Not selectable for single-phase / 3-wire system.)
 - 4: 380, 400, 415, 430, 440, 480 V AC
(Not selectable for single-phase / 3-wire system.)
- A: 100 V / 200 V AC
(single-phase / 3-wire only)

[3] CT INPUT (unbalanced load)

Current

- 1: 1 A AC
- 2: 2 A AC
- 5: 5 A AC

[4] DC OUTPUT

Current

- A: 4 - 20 mA DC (Load resistance 500 Ω max.)
 D: 0 - 20 mA DC (Load resistance 500 Ω max.)
 F: 0 - 10 mA DC (Load resistance 1000 Ω max.)
 G: 0 - 1 mA DC (Load resistance 10 k Ω max.)
 J: 0 - 5 mA DC (Load resistance 2000 Ω max.)
 FW: -10 - +10 mA DC (Load resistance 1000 Ω max.)
 GW: -1 - +1 mA DC (Load resistance 10 k Ω max.)
 JW: -5 - +5 mA DC (Load resistance 2000 Ω max.)
 Z: Specify current (See OUTPUT SPECIFICATIONS)

Voltage

- 1: 0 - 10 mV DC (Load resistance 10 k Ω min.)
 - 2: 0 - 100 mV DC (Load resistance 100 k Ω min.)
 - 3: 0 - 1 V DC (Load resistance 1000 Ω min.)
 - 4: 0 - 10 V DC (Load resistance 10 k Ω min.)
 - 5: 0 - 5 V DC (Load resistance 5000 Ω min.)
 - 6: 1 - 5 V DC (Load resistance 5000 Ω min.)
- 1W: -10 - +10 mV DC (Load resistance 10 k Ω min.)
 2W: -100 - +100 mV DC (Load resistance 100 k Ω min.)
 3W: -1 - +1 V DC (Load resistance 1000 Ω min.)
 4W: -10 - +10 V DC (Load resistance 10 k Ω min.)
 5W: -5 - +5 V DC (Load resistance 5000 Ω min.)



0: Specify voltage (See OUTPUT SPECIFICATIONS)

[5] PULSE OUTPUT (open collector)

0: None

1: 2.777 Hz at 100 % input

2: Specify pulse unit (within 0.006 - 3.12 Hz)

[6] AUXILIARY POWER SUPPLY

AC Power

K3: 100 - 120V AC

(Operational voltage range 85 - 132 V, 47 - 66 Hz)

L3: 200 - 240V AC

(Operational voltage range 170 - 264 V, 47 - 66 Hz)

DC Power

R: 24 V DC

(Operational voltage range 24 V ±10 %, ripple 10 %p-p max.)

V: 48 V DC

(Operational voltage range 48 V ± 10 %, ripple 10 % p-p max.)

P: 110 V DC

(Operational voltage range 85 - 150 V, ripple 10 %p-p max.)

(CE not available)

[7] OPTIONS

Terminal Cover

blank: Without

/T: With

GENERAL SPECIFICATIONS

Connection: M4 screw terminals (torque 1.2 N·m)

Screw terminal: Chrome-plated steel

Housing material: Flame-resistant resin (black)

Isolation: Voltage input to current input to DC output to pulse output to power

Computation: Time division multiplication

Overrange output: Approx. -10 to +120 % at 1 - 5 V

Zero adjustment(DC output): -5 to + 5 % (front)

Span adjustment(DC output): 95 to + 105 % (front)

INPUT SPECIFICATIONS

Frequency: 50 or 60 Hz

• Voltage input

Operational range: 0 - 120 % of rating

Overload capacity: 200 % of rating for 10 sec., 120 % continuous

• Current input

Operational range: 0 - 120 % of rating

Overload capacity: 4000 % of rating for 1 sec., 2000 % for 4 sec., 120 % continuous

■ How to determine Wattage Range

Calibration Range [W] = Measuring Wattage ÷ ((VT Ratio)

× (CT Ratio))

Check that the required calibration range is within the available range in the table. Specify this range when ordering.

[Example]

3-phase / 3-wire, measuring wattage 750 kW,

VT 3300/110 V, CT 250/5 A

$750 \times 10^3 [W] \div ((3300 \div 110) \times (250 \div 5)) = 0 - 500 [W]$

■ INPUT RANGE

• Single-phase / 2-wire

INPUT		USABLE RANGE	BURDEN (VA)	
VT/CT CODE	STD.RANGE		VT	CT
1/1	±100 W	±50 - ±120 W	0.2	0.1
1/2	±200 W	±100 - ±240 W		0.2
1/5	±500 W	±250 - ±600 W		0.5
2/1	±200 W	±100 - ±240 W	0.4	0.1
2/2	±400 W	±200 - ±480 W		0.2
2/5	±1000 W	±500 - ±1200 W		0.5
4/1	±400 W	±200 - ±480 W	0.6	0.1
4/2	±800 W	±400 - ±960 W		0.2
4/5	±2000 W	±1000 - ±2400 W		0.5

• Single-phase / 3-wire

INPUT		USABLE RANGE	BURDEN (VA)	
VT/CT CODE	STD.RANGE		VT	CT
A/1	±200 W	±100 - ±240 W	0.2 /phase	0.1/ph
A/2	±400 W	±200 - ±480 W		0.2/ph
A/5	±1000 W	±500 - ±1200 W		0.5/ph

• 3-phase / 3-wire

INPUT		USABLE RANGE	BURDEN (VA)	
VT/CT CODE	STD.RANGE		VT	CT
1/1	±200 W	±100 - ±240 W	0.2 /phase	0.1/ph
1/2	±400 W	±200 - ±480 W		0.2/ph
1/5	±1000 W	±500 - ±1200 W		0.5/ph
2/1	±400 W	±200 - ±480 W	0.4 /phase	0.1/ph
2/2	±800 W	±400 - ±960 W		0.2/ph
2/5	±2000 W	±1000 - ±2400 W		0.5/ph
4/1	±800 W	±400 - ±960 W	0.6 /phase	0.1/ph
4/2	±1600 W	±800 - ±1920 W		0.2/ph
4/5	±4000 W	±2000 - ±4800 W		0.5/ph

• 3-phase / 4-wire

INPUT		USABLE RANGE	BURDEN (VA)	
VT/CT CODE	STD.RANGE		VT	CT
1/1	±200 W	±100 - ±240 W	0.1 /phase	0.1/ph
1/2	±400 W	±200 - ±480 W		0.2/ph
1/5	±1000 W	±500 - ±1200 W		0.5/ph
2/1	±400 W	±200 - ±480 W	0.3 /phase	0.1/ph
2/2	±800 W	±400 - ±960 W		0.2/ph
2/5	±2000 W	±1000 - ±2400 W		0.5/ph
4/1	±800 W	±400 - ±960 W	0.4 /phase	0.1/ph
4/2	±1600 W	±800 - ±1920 W		0.2/ph
4/5	±4000 W	±2000 - ±4800 W		0.5/ph

OUTPUT SPECIFICATIONS

■ DC Current: -10 - +20 mA DC

Span: Min. 1 mA, max. 20 mA

Offset: Max. 1.5 times span



Load resistance: Output drive 10 V max.

■ **DC Voltage:** -10 - +12 V DC

Minimum span: 5 mV

Offset: Max. 1.5 times span

Load resistance: Output drive 1 mA max. at ≥ 0.5 V

■ **Pulse output:** Open collector

0 Hz at 0 W (cutout at approx. 0.5 - 1.0 %)

Rating: 35 V DC @ 100 mA

ON voltage: ≤ 1 V at 100 mA

ON duration: Max. 0.5 sec., min. 50 msec. (approx.)

Frequency range: 0 - 2.777 Hz (0 - 100 %) standard; 0 - 0.006 Hz through 3.12 Hz is possible.

• **2.777 Hz at 100 % Input**

[Example] 1000 W calibration range

$2.777 \text{ [Hz]} \times 3600 \text{ [s]} \div 1 \text{ [kW]} = 10000 \text{ [pulses/kWh]}$

• **Specified Pulse Unit:** Refers to how much electrical energy (kWh) consumption at the primary of the VT and CT corresponds to the single output pulse per hour from the transducer.

■ **OPERATION DIAGRAM (example)**

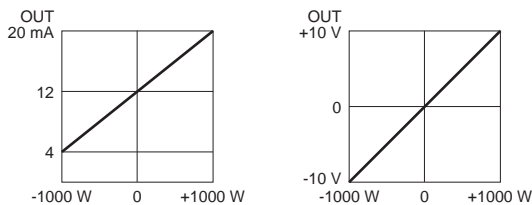
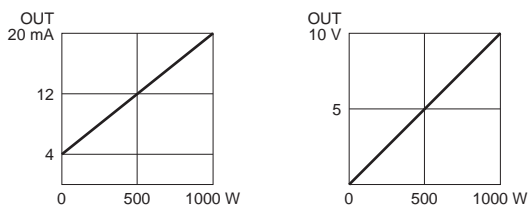

signal and power supply)

Line voltage effect: ± 0.25 % over voltage range

Insulation resistance: ≥ 100 M Ω with 500 V DC

Dielectric strength: 2000 V AC @ 1 minute

(voltage input to current input to DC output to pulse output to power to ground)

Impulse withstand voltage: 1.2 / 50 μ sec., ± 5 kV (input to output or ground)

STANDARDS & APPROVALS

CE conformity:

EMC Directive (2004/108/EC)

EMI EN 61000-6-4: 2007

EMS EN 61000-6-2: 2005

Low Voltage Directive (2006/95/EC)

EN 61010-1: 2001

Measurement Category II (input, output)

Installation Category II (power)

Pollution Degree 2

Input to output or power: Reinforced insulation (550 V)

Output to power: Reinforced insulation (300 V)

IEC Standard: IEC 60688

INSTALLATION

Power Consumption

• **AC:** Approx. 2 VA

• **DC:** Approx. 2 W (18 mA at 110 V)

Operating temperature: -10 to +55°C (14 to 131°F)

Operating humidity: 30 to 85 %RH (non-condensing)

Mounting: Surface or DIN rail

Weight: 450 g (0.99 lb)

PERFORMANCE in percentage of span

Accuracy: ± 0.5 % (at 23°C ± 10 °C or 73.4°F ± 18 °F, 45 - 65 Hz)

Magnetic field (ext. origin) effect: ± 0.5 % (400 A/m)

Response time: ≤ 2 sec. (0 - 100 % ± 1 %)

Ripple: 0.5 %p-p max. (The output ripple may increase when there is great difference between the frequencies of input



CONNECTION DIAGRAM

3-PHASE/3-WIRE

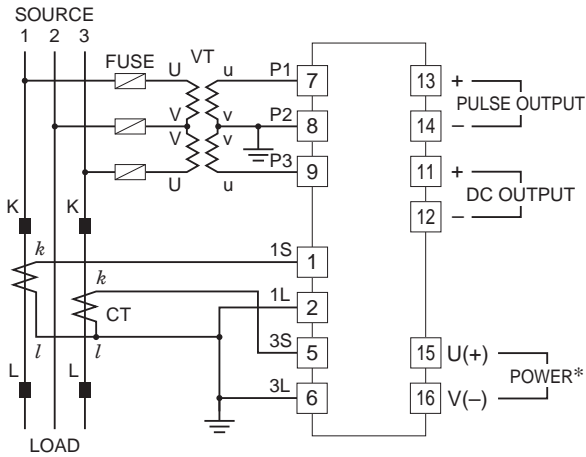

SINGLE-PHASE/2-WIRE

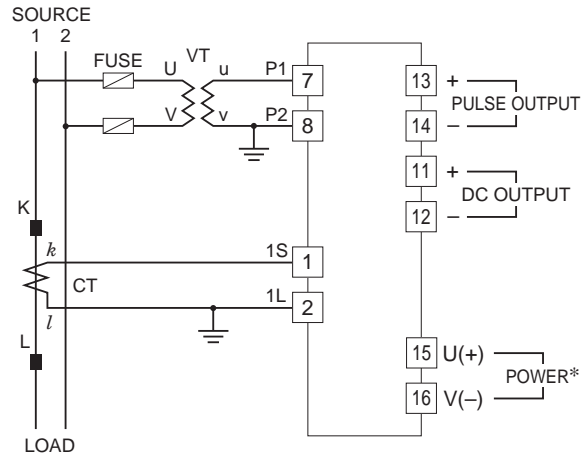

SINGLE-PHASE/3-WIRE

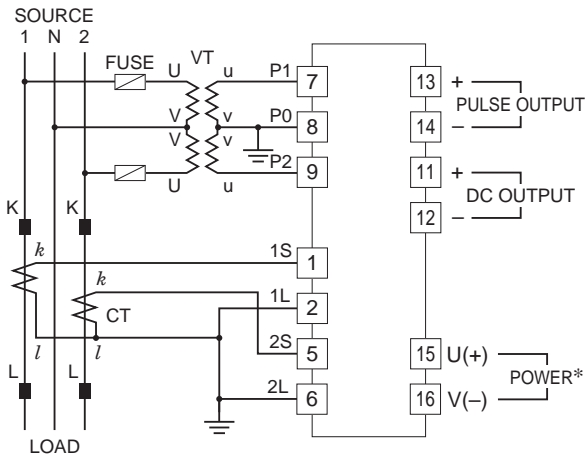

3-PHASE/4-WIRE

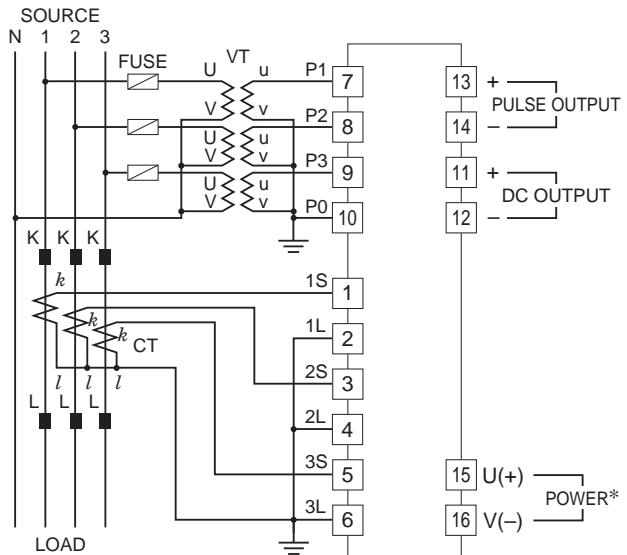

Pulse Output Connection Example

Open Collector

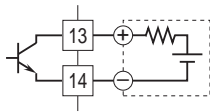

*The transducer can be powered from the input voltage when the voltage is sufficiently stable and meets within the range of auxiliary power supply of the unit specified in the data sheet/instruction manual.

EXTERNAL DIMENSIONS & TERMINAL ASSIGNMENTS unit: mm (inch)

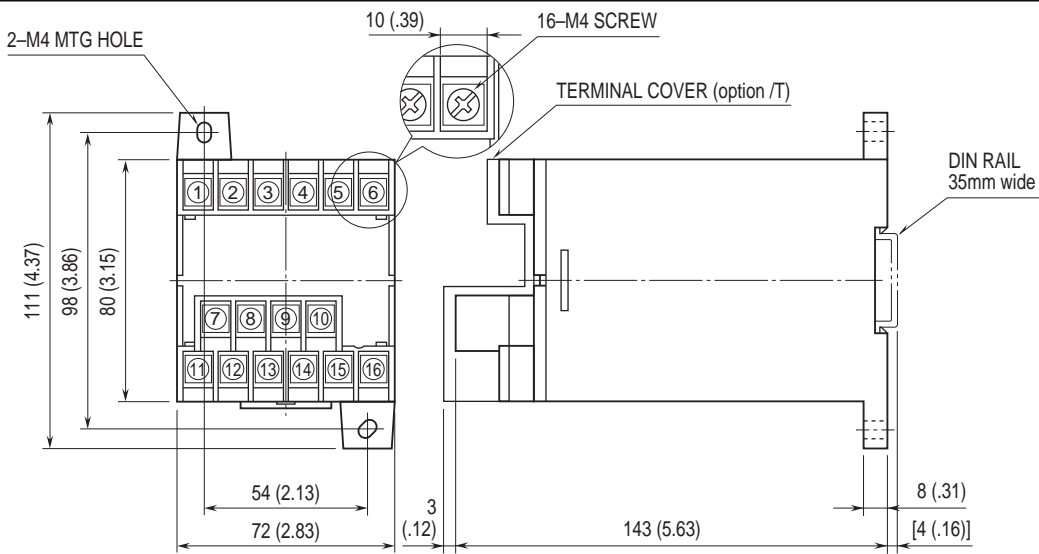

• When mounting, no extra space is needed between units.



Specifications are subject to change without notice.