

Power Transducer Series LT-UNIT

PHASE ANGLE TRANSDUCER

(for unbalanced load; self-powered)

Functions & Features

- Provides a DC output signal in proportion to phase angle
- Usable with unbalanced load
- DC output containing little ripple is ideal for computer input
- Isolation up to 2000 V AC
- High-density mounting
- Conforms to IEC 60688
- No auxiliary power supply required

Typical Applications

- Centralized monitoring and control of power management system in a manufacturing facility or building
- Measuring phase angle for a motor

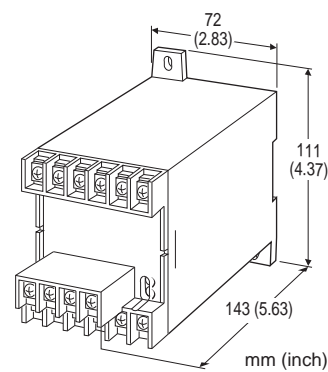

MODEL: LTPAUN-[1][2][3][4][5][6][7]

ORDERING INFORMATION

- Code number: LTPAUN-[1][2][3][4][5][6][7]
- Specify a code from below for each [1] through [7]. (e.g. LTPAUN-1151PA/T)
- Special output range (For codes Z & 0)

[1] CONFIGURATION

- 1: 3-phase / 3-wire
- 4: 3-phase / 4-wire

[2] VT INPUT (balanced load)

For 3-phase / 4-wire, phase voltages (e.g. 110 V / $\sqrt{3}$) are used.

- 1: 110 V AC
- 2: 220 V AC
- 4: 220 V / 380 V AC (3-phase/4-wire only)

[3] CT INPUT (unbalanced load)

Current

- 1: 1 A AC
- 2: 2 A AC
- 5: 5 A AC

[4] FREQUENCY

- 1: 50 Hz
- 2: 60 Hz

[5] OUTPUT SIGNAL POLARITY

- P: Negative in lag, positive in lead
- M: Negative in lead, positive in lag

[6] OUTPUT

Current

- A: 4 - 20 mA DC (Load resistance 500 Ω max.)
- FW: -10 - +10 mA DC (Load resistance 1000 Ω max.)
- GW: -1 - +1 mA DC (Load resistance 10 k Ω max.)
- JW: -5 - +5 mA DC (Load resistance 2000 Ω max.)
- Z: Specify current (See OUTPUT SPECIFICATIONS)

Voltage

- 6: 1 - 5 V DC (Load resistance 5000 Ω min.)
- 1W: -10 - +10 mV DC (Load resistance 10 k Ω min.)
- 2W: -100 - +100 mV DC (Load resistance 100 k Ω min.)
- 3W: -1 - +1 V DC (Load resistance 1000 Ω min.)
- 4W: -10 - +10 V DC (Load resistance 10 k Ω min.)
- 5W: -5 - +5 V DC (Load resistance 5000 Ω min.)
- 0: Specify voltage (See OUTPUT SPECIFICATIONS)

[7] OPTIONS

Terminal Cover

- blank: Without
- /T: With

GENERAL SPECIFICATIONS

- Connection: M4 screw terminals (torque 1.2 N·m)
- Screw terminal: Chrome-plated steel
- Housing material: Flame-resistant resin (black)
- Isolation: Voltage input to current input to output
- Computation: Phase angle detection
- Overrange output: Approx. -10 to +120 % at 1 - 5 V
- Zero adjustment: -5 to +5 % (front)
- Span adjustment: 95 to 105 % (front)

INPUT SPECIFICATIONS

Frequency: 50 or 60 Hz

■ VOLTAGE INPUT

Operational range: 85 - 110 % of rating



Overload capacity: 150 % of rating for 10 sec., 110 % continuous

Input burden: 2.5 VA

■ **CURRENT INPUT**

Operational range: 10 – 120 % of rating

Overload capacity: 4000 % of rating for 1 sec., 2000 % for 4 sec., 120 % continuous

Input burden: 0.1 VA (input 1 A)

0.2 VA (input 2 A)

0.5 VA (input 5 A)

■ **Input range:**

lag 60°- 0 - lead 60°

lead 60°- 0 - lag 60°

OUTPUT SPECIFICATIONS

■ **DC Current:** -10 – +20 mA DC

Span: Min. 1 mA, max. 20 mA

Offset: Max. 1.5 times span

Load resistance: Output drive 10 V max.

■ **DC Voltage:** -10 – +12 V DC

Minimum span: 5 mV

Offset: Max. 1.5 times span

Load resistance: Output drive 1 mA max. at ≥ 0.5 V

■ **OPERATION DIAGRAM (example)**

• **Negative in lag, positive in lead**

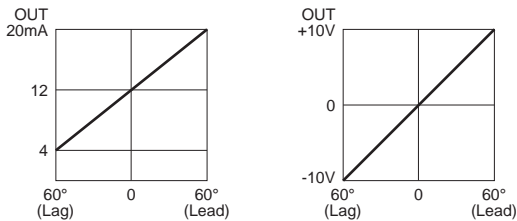

• **Negative in lead, positive in lag**

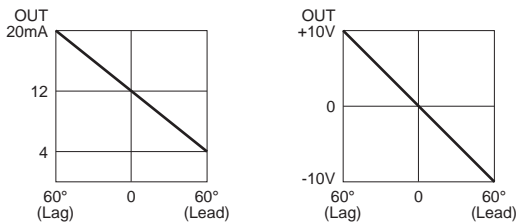

Remark: When there is 5% or less of the rated input current, the transducer output equals approximately to '0' (phase angle).

INSTALLATION

Operating temperature: -10 to +55°C (14 to 131°F)

Operating humidity: 30 to 85 %RH (non-condensing)

Mounting: Surface or DIN rail

Weight: 450 g (0.99 lb)

PERFORMANCE in percentage of span

Accuracy: ± 2 % with balanced load

(at 23°C ± 10 °C or 73.4°F ± 18 °F, at rated frequency ± 10 % [± 5 % for 3-phase/4 wire])

Magnetic field (ext. origin) effect: ± 2 % (400 A/m)

Response time: ≤ 2 sec. (0 – 100 % ± 1 %)

Ripple: 0.5 %p-p max.

Insulation resistance: ≥ 100 M Ω with 500 V DC

Dielectric strength: 2000 V AC @ 1 minute

(voltage input to current input to output to ground)

Impulse withstand voltage: 1.2 / 50 μ sec., ± 5 kV

(input to output or ground)

STANDARDS & APPROVALS

CE conformity:

EMC Directive (2004/108/EC)

EMI EN 61000-6-4: 2007

EMS EN 61000-6-2: 2005

Low Voltage Directive (2006/95/EC)

EN 61010-1: 2001

Measurement Category II

Pollution Degree 2

Input to output: Reinforced insulation (300 V)

IEC Standard: IEC 60688



CONNECTION DIAGRAM

■ 3-PHASE/3-WIRE

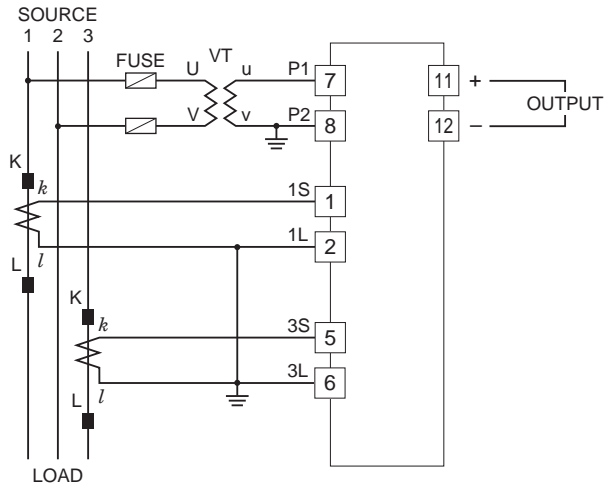

■ 3-PHASE/4-WIRE

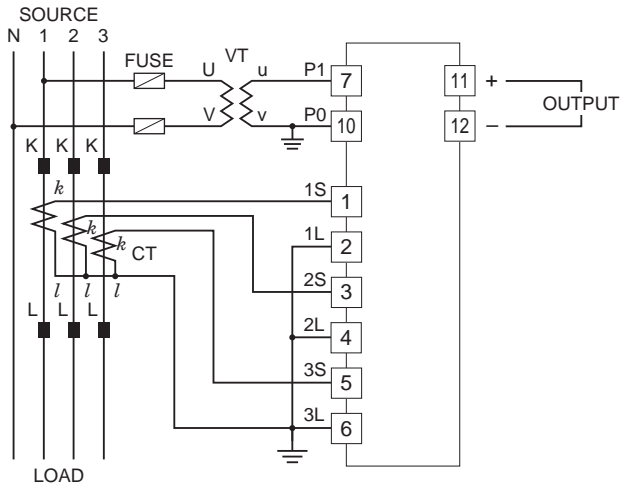

EXTERNAL DIMENSIONS & TERMINAL ASSIGNMENTS unit: mm (inch)

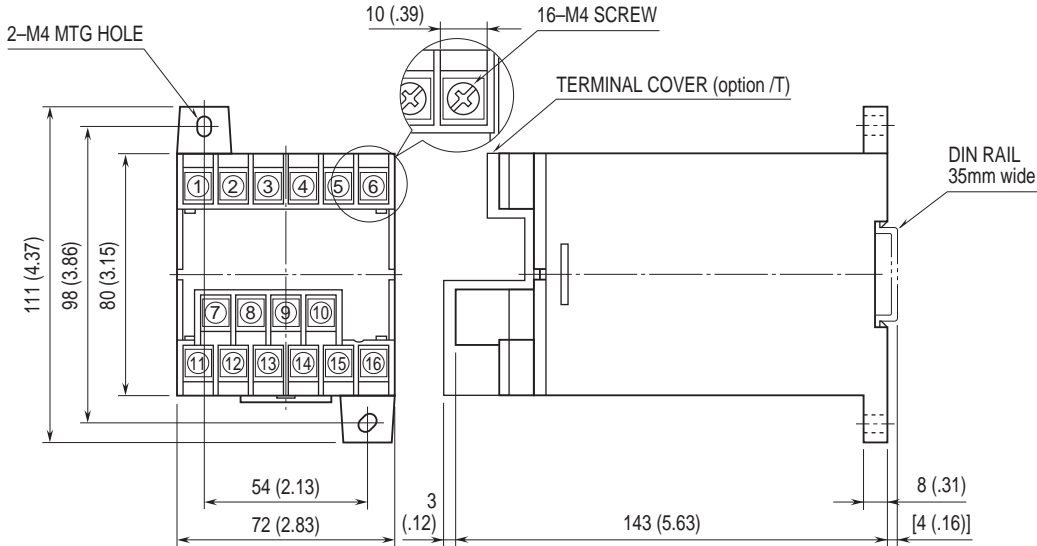

• When mounting, no extra space is needed between units.



Specifications are subject to change without notice.

