

Power Transducer Series LT-UNIT

PHASE ANGLE TRANSDUCER

(for unbalanced load)

Functions & Features

- Provides a DC output signal in proportion to phase angle
- Usable with unbalanced load
- DC output containing little ripple is ideal for computer input
- Isolation up to 2000 V AC
- High-density mounting
- Conforms to IEC 60688

Typical Applications

- Centralized monitoring and control of power management system in a manufacturing facility or building
- Measuring phase angle for a motor

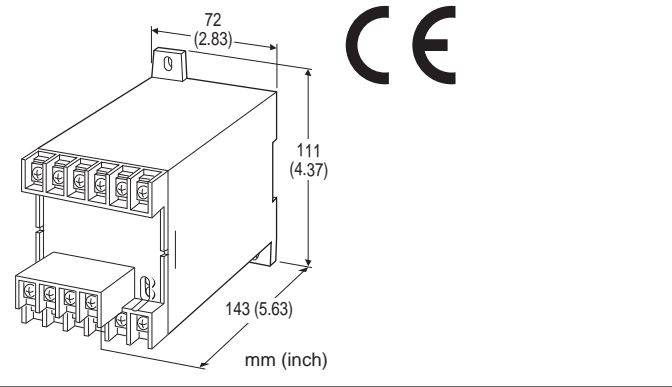

MODEL: LTPAU-[1][2][3][4][5][6]-[7][8]

ORDERING INFORMATION

- Code number: LTPAU-[1][2][3][4][5][6]-[7][8]
Specify a code from below for each [1] through [8].
(e.g. LTPAU-1151PA-R/T)
- Special output range (For codes Z & 0)

[1] CONFIGURATION

- 1: 3-phase / 3-wire
- 4: 3-phase / 4-wire

[2] VT INPUT (balanced load)

For 3-phase / 4-wire, phase voltages (e.g. 110 V / $\sqrt{3}$) are used.

- 1: 100, 110, 115, 120 V AC
- 2: 190, 200, 210, 220, 230, 240 V AC
- 4: 380, 400, 415, 430, 440, 480 V AC

[3] CT INPUT (unbalanced load)

Current

- 1: 1 A AC
- 2: 2 A AC
- 5: 5 A AC

[4] FREQUENCY

- 1: 50 Hz
- 2: 60 Hz

[5] OUTPUT SIGNAL POLARITY

- P: Negative in lag, positive in lead
- M: Negative in lead, positive in lag

[6] OUTPUT

Current

- A: 4 - 20 mA DC (Load resistance 500 Ω max.)
- FW: -10 - +10 mA DC (Load resistance 1000 Ω max.)
- GW: -1 - +1 mA DC (Load resistance 10 k Ω max.)
- JW: -5 - +5 mA DC (Load resistance 2000 Ω max.)
- Z: Specify current (See OUTPUT SPECIFICATIONS)

Voltage

- 6: 1 - 5 V DC (Load resistance 5000 Ω min.)
- 1W: -10 - +10 mV DC (Load resistance 10 k Ω min.)
- 2W: -100 - +100 mV DC (Load resistance 100 k Ω min.)
- 3W: -1 - +1 V DC (Load resistance 1000 Ω min.)
- 4W: -10 - +10 V DC (Load resistance 10 k Ω min.)
- 5W: -5 - +5 V DC (Load resistance 5000 Ω min.)
- 0: Specify voltage (See OUTPUT SPECIFICATIONS)

[7] AUXILIARY POWER SUPPLY

AC Power

- K3: 100 - 120V AC
(Operational voltage range 85 - 132 V, 47 - 66 Hz)
- L3: 200 - 240V AC
(Operational voltage range 170 - 264 V, 47 - 66 Hz)

DC Power

- R: 24 V DC
(Operational voltage range 24 V \pm 10 %, ripple 10 %p-p max.)
- V: 48 V DC
(Operational voltage range 48 V \pm 10 % , ripple 10 % p-p max.)
- P: 110 V DC
(Operational voltage range 85 - 150 V, ripple 10 %p-p max.)
(CE not available)

[8] OPTIONS

Terminal Cover

- blank: Without
- /T: With



GENERAL SPECIFICATIONS

Connection: M4 screw terminals (torque 1.2 N·m)
Screw terminal: Chrome-plated steel
Housing material: Flame-resistant resin (black)
Isolation: Voltage input to current input to output to power
Computation: Phase angle detection
Overrange output: Approx. -10 to +120 % at 1 - 5 V
Zero adjustment: -5 to +5 % (front)
Span adjustment: 95 to 105 % (front)

INPUT SPECIFICATIONS

Frequency: 50 or 60 Hz

VOLTAGE INPUT

Operational range: 85 - 120 % of rating
Overload capacity: 150 % of rating for 10 sec., 120 % continuous

Input burden: 0.5 VA

CURRENT INPUT

Operational range: 10 - 120 % of rating
Overload capacity: 4000 % of rating for 1 sec., 2000 % for 4 sec., 120 % continuous

Input burden: 0.1 VA (input 1 A)

0.2 VA (input 2 A)

0.5 VA (input 5 A)

Input range:

lag 60° - 0 - lead 60°

lead 60° - 0 - lag 60°

OUTPUT SPECIFICATIONS

DC Current: -10 - +20 mA DC

Span: Min. 1 mA, max. 20 mA

Offset: Max. 1.5 times span

Load resistance: Output drive 10 V max.

DC Voltage: -10 - +12 V DC

Minimum span: 5 mV

Offset: Max. 1.5 times span

Load resistance: Output drive 1 mA max. at ≥ 0.5 V

OPERATION DIAGRAM (example)

Negative in lag, positive in lead

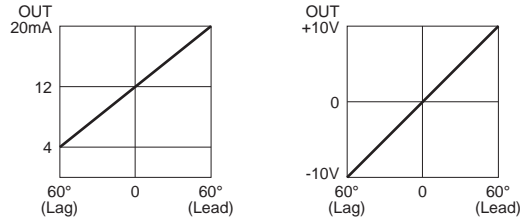

Negative in lead, positive in lag

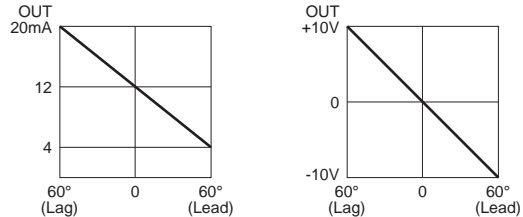

Remark: When there is no input voltage or 5% or less of the rated input current, the transducer output equals approximately to '0' (phase angle).

INSTALLATION

Power Consumption

•AC: Approx. 2 VA

•DC: Approx. 2 W (18 mA at 110 V)

Operating temperature: -10 to +55°C (14 to 131°F)

Operating humidity: 30 to 85 %RH (non-condensing)

Mounting: Surface or DIN rail

Weight: 450 g (0.99 lb)

PERFORMANCE in percentage of span

Accuracy: ± 2 % with balanced load

(at 23°C ± 10 °C or 73.4°F ± 18 °F, at rated frequency ± 10 % [± 5 % for 3-phase/4 wire])

Magnetic field (ext. origin) effect: ± 2 % (400 A/m)

Response time: ≤ 2 sec. (0 - 100 % ± 1 %)

Ripple: 0.5 %p-p max.

Line voltage effect: ± 1 % over voltage range

Insulation resistance: ≥ 100 M Ω with 500 V DC

Dielectric strength: 2000 V AC @ 1 minute

(voltage input to current input to output to power to ground)

Impulse withstand voltage: 1.2 / 50 μ sec., ± 5 kV

(input to output or ground)

STANDARDS & APPROVALS

CE conformity:

EMC Directive (2004/108/EC)

EMI EN 61000-6-4: 2007

EMS EN 61000-6-2: 2005

Low Voltage Directive (2006/95/EC)

EN 61010-1: 2001



幸託有限公司
 XIN TOP CORPORATION

TEL : (02)2598-1199

FAX : (02)2596-2331

E-mail : info@xintop.com

Website : www.xintop.com

Measurement Category II (input, output)
 Installation Category II (power)
 Pollution Degree 2
 Input to output or power: Reinforced insulation (550 V)
 Output to power: Reinforced insulation (300 V)
IEC Standard: IEC 60688

CONNECTION DIAGRAM

■ 3-PHASE/3-WIRE

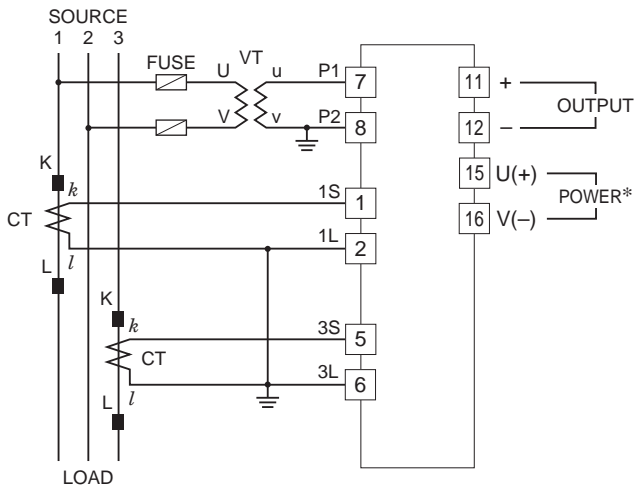

■ 3-PHASE/4-WIRE

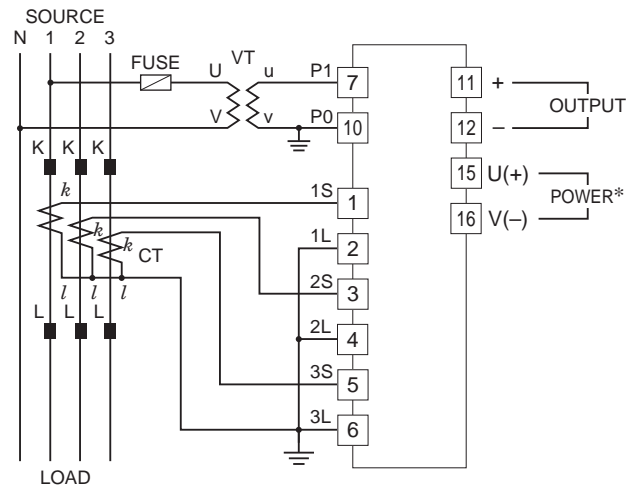

*The transducer can be powered from the input voltage when the voltage is sufficiently stable and meets within the range of auxiliary power supply of the unit specified in the data sheet/instruction manual.

EXTERNAL DIMENSIONS & TERMINAL ASSIGNMENTS unit: mm (inch)

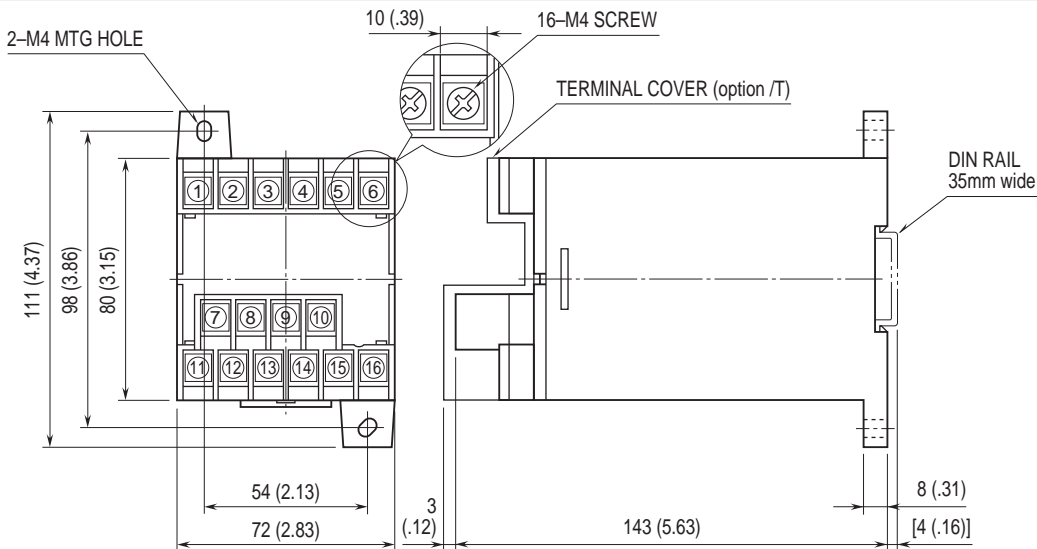

• When mounting, no extra space is needed between units.



Specifications are subject to change without notice.



幸託有限公司
 XIN TOP CORPORATION

TEL : (02)2598-1199
 FAX : (02)2596-2331

E-mail : info@xintop.com
 Website : www.xintop.com