

Plug-in Signal Conditioners M-UNIT

STRAIN GAUGE TRANSMITTER

(non-isolated)

Functions & Features

- Providing a DC output signal proportional to a bridge type strain gauge utilized in load cells, pressure transducers
- Supplying required excitation voltage
- Drives bridges 80 Ω or above
- Excitation adjustable from 2 V to 10 V
- Wide-range adjustment: 0 - 80 % for zero, 20 - 100 % for span
- Fast response type available
- LCD meter (engineering unit display selectable)
- Simple loop test output (0 % and 100 %)
- High-density mounting

Typical Applications

- Weighing system for tanks, hoppers, silos
- Weighing system using cranes
- Float level meter utilizing strain gauges

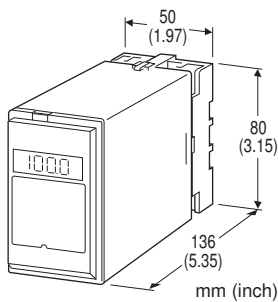

MODEL: LC-[1][2]-[3][4]

ORDERING INFORMATION

- Code number: LC-[1][2]-[3][4]
- Specify a code from below for each [1] through [4]. (e.g. LC-2A-B/E2E/Q)
- Special output range (For codes Z & 0)
- Specify the specification for option code /Q (e.g. /C01/S01)

[1] INPUT STRAIN GAUGE

- 1: 1 mV/V
- 12: 1.25 mV/V
- 15: 1.5 mV/V
- 2: 2 mV/V
- 3: 3 mV/V
- 4: 4 mV/V
- 5: 5 mV/V

- 6: 10 mV/V
- 7: 20 mV/V
- 0: Specify (strain gauge and excitation)

[2] OUTPUT

Current

- A: 4 - 20 mA DC (Load resistance 750 Ω max.)
- B: 2 - 10 mA DC (Load resistance 1500 Ω max.)
- C: 1 - 5 mA DC (Load resistance 3000 Ω max.)
- D: 0 - 20 mA DC (Load resistance 750 Ω max.)
- E: 0 - 16 mA DC (Load resistance 900 Ω max.)
- F: 0 - 10 mA DC (Load resistance 1500 Ω max.)
- G: 0 - 1 mA DC (Load resistance 15 kΩ max.)
- Z: Specify current (See OUTPUT SPECIFICATIONS)

Voltage

- 1: 0 - 10 mV DC (Load resistance 10 kΩ min.)
- 2: 0 - 100 mV DC (Load resistance 100 kΩ min.)
- 3: 0 - 1 V DC (Load resistance 100 Ω min.)
- 4: 0 - 10 V DC (Load resistance 1000 Ω min.)
- 5: 0 - 5 V DC (Load resistance 500 Ω min.)
- 6: 1 - 5 V DC (Load resistance 500 Ω min.)
- 4W: -10 - +10 V DC (Load resistance 2000 Ω min.)
- 5W: -5 - +5 V DC (Load resistance 1000 Ω min.)
- 0: Specify voltage (See OUTPUT SPECIFICATIONS)

[3] POWER INPUT

AC Power

- B: 100 V AC
- C: 110 V AC
- D: 115 V AC
- F: 120 V AC
- G: 200 V AC
- H: 220 V AC
- J: 240 V AC

DC Power

- R: 24V DC (Not selectable with option /E or /E2)

[4] OPTIONS (multiple selections)

Input Signal Indicator

- blank: Without
- /E: With (0.0 - 100.0 % display)
- /E2: With (in engineering unit with backlight and the simple loop test output)

Other Options

- blank: none
- /Q: Option other than the above (specify the specification)

SPECIFICATIONS OF OPTION: Q (multiple selections)

- COATING (For the detail, refer to M-System's web site.)**
- /C01: Silicone coating



/C02: Polyurethane coating

/C03: Rubber coating

TERMINAL SCREW MATERIAL

/S01: Stainless steel

GENERAL SPECIFICATIONS

Construction: Plug-in

Connection: M3.5 screw terminals

Screw terminal: Chromated steel (standard) or stainless steel

Housing material: Flame-resistant resin (black)

Isolation: Input or output to power

Overrange output: Approx. -10 to +120 % at 1 - 5 V

Excitation adjustment: 2 - 10 V (front)

Zero adjustments (tare): 0 - 80 % (front)

(Excitation voltage: factory default)

Span adjustment: 100 - 20 % (front)

(Excitation voltage: factory default)

Display scaling: -10000 - +10000; ex-factory set to 0.00 - 100.00 (%)

Engineering unit: %, μ V, mV, V, mA, A, °C, °F, Ω , DEG K, mHz, Hz, kHz, VAC, AAC, mg, g, kg, t, rpm or rps selectable

Simple loop test output: 0 % and 100 % signal simulated by selecting the front switch positions.

approx. 150 mA, ripple 10 %p-p max. (approx. 200 mA with Option /E2)

Operating temperature: -5 to +60°C (23 to 140°F)

Operating humidity: 30 to 90 %RH (non-condensing)

Mounting: Surface or DIN rail

Weight: 430 g (0.95 lb)

PERFORMANCE in percentage of span

Accuracy: ± 0.1 % (Input ≥ 3 mV)

Display accuracy: $\pm (0.1$ % of FS + 1 digit)
(Input ≥ 3 mV)

Simple loop test output setting accuracy: ± 0.5 %

Temp. coefficient: ± 0.015 %/°C (± 0.008 %/°F)

Response time: ≤ 0.5 sec. (0 - 90 %)

Line voltage effect: ± 0.1 % over voltage range

Insulation resistance: ≥ 100 M Ω with 500 V DC

Dielectric strength: 2000 V AC @1 minute for AC power

1000 V AC @1 minute for DC power

(input or output to power)

2000 V AC @1 minute

(input or output or power to ground)

INPUT SPECIFICATIONS

■ **Input:** Bridge voltage from load cells

• **Strain Gauge**

Rated output from strain gauge: 1 - 20 mV/V;

Input to the transmitter must be over 3 mV.

• **Excitation:** 2 - 10 V adjustable (5 V standard)

Maximum current: 35 mA at 10 V, 65 mA at ≤ 7.5 V

OUTPUT SPECIFICATIONS

■ **DC Current:** 0 - 20 mA DC

Minimum span: 1 mA

Offset: Max. 1.5 times span

Load resistance: Output drive 15 V max.

■ **DC Voltage:** -10 - +12 V DC

Minimum span: 5 mV

Offset: Max. 1.5 times span

Load resistance: Output drive 10 mA max.; 5 mA for negative voltage output; at ≥ 0.5 V

INSTALLATION

Power input

• **AC:** Operational voltage range: rating ± 10 %, 50/60 ± 2 Hz, approx. 3 VA

(approx. 4 VA with Option /E2)

• **DC:** Operational voltage range: 24 V ± 10 %,



EXTERNAL VIEW

■ Option /E

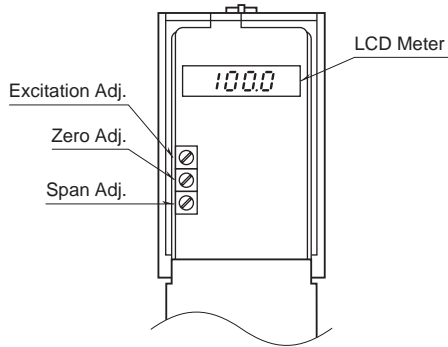

■ Option /E2

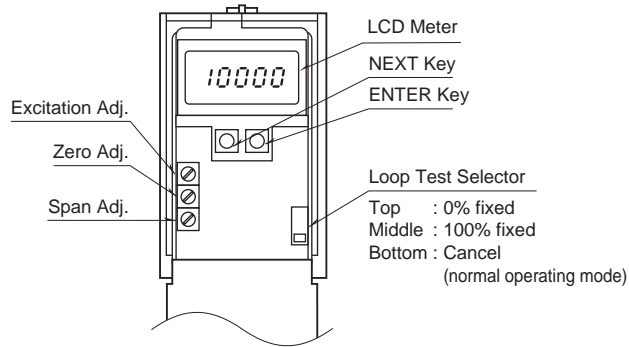

EXTERNAL DIMENSIONS & TERMINAL ASSIGNMENTS unit: mm (inch)

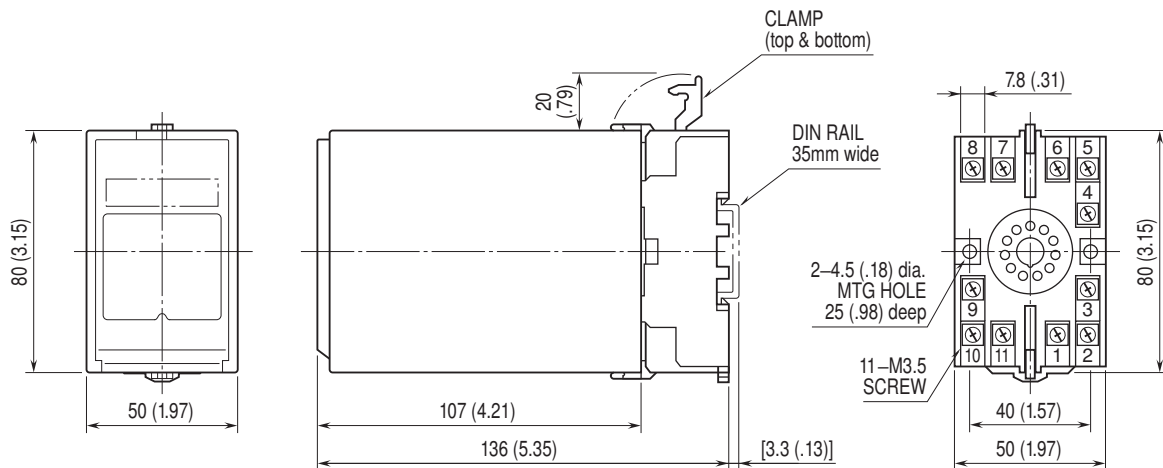

• When mounting, no extra space is needed between units.

SCHEMATIC CIRCUITRY & CONNECTION DIAGRAM

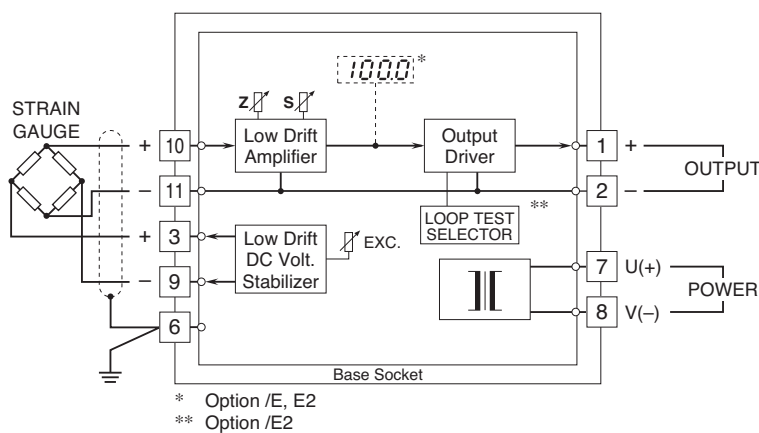

Specifications are subject to change without notice.



幸託有限公司
 XIN TOP CORPORATION

TEL : (02)2598-1199
 FAX : (02)2596-2331

E-mail : info@xintop.com
 Website : www.xintop.com