

Power Transducer Series

MULTI POWER TRANSDUCER

Functions & Features

- Measures simultaneously several variables of a heavy-current power system: current, voltage, active, reactive, and apparent power, active and reactive energy, power factor, frequency, etc.
- All measured values, counter values, setting data are stored in the non-volatile memory at the power off.
- Conversion factors, system configuration, interval times are programmable.
- Open collector output for alarm or energy count.

Typical Applications

- Multi-functional power measurement in electric device or in switching boards.

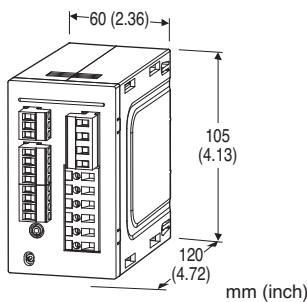

MODEL: L53U-1[1][2][3]-AD4[4]

ORDERING INFORMATION

- Code number: L53U-1[1][2][3]-AD4[4]
- Specify a code from below for each [1] through [4].
(e.g. L53U-1211-AD4/H/Q)
- Specify the specification for option code /Q
(e.g. /SET)

CONFIGURATION

- 1: Single-phase / 2-wire and 3-wire,
3-phase / 3-wire and 4-wire

[1] INPUT

- 1: 480 V / 1 A AC
2: 480 V / 5 A AC

[2] DISCRETE INPUT

- 0: None
('External Interface' codes 1, 4 and 5 Not selectable.)
1: 24 V DC

- ('External Interface' codes 2, 3, 6 and 7 Not selectable.)
2: 110 V DC
('External Interface' codes 2, 3, 6 and 7 Not selectable.)

[3] EXTERNAL INTERFACE

- 1: Modbus, Do × 1, Di × 1
2: 4 - 20 mA DC × 4
3: 1 - 5 V DC × 4
4: 4 - 20 mA DC × 2, Do × 1, Di × 1
5: 1 - 5 V DC × 2, Do × 1, Di × 1
6: 4 - 20 mA DC × 2, Do × 2
7: 1 - 5 V DC × 2, Do × 2

AUXILIARY POWER SUPPLY

- AD4: universal
100 - 240 V AC (Operational range 85 - 264 V, 50 / 60 Hz) /
110 - 240 V DC (Operational range 99 - 264 V,
ripple 10 %p-p max)

[4] OPTIONS (multiple selections)

Performance

blank: Standard

/H: High accuracy (voltage/current: ±0.2 %, energy: ±0.5 %)

Other Options

blank: none

/Q: Option other than the above (specify the specification)

SPECIFICATIONS OF OPTION: Q

EX-FACTORY SETTING

/SET: Preset according to the Ordering Information Sheet
(No. ESU-1958)

RELATED PRODUCTS

- PC configurator software (model: PMCFG)
- PC Recorder Light software for the 53U (model: MSR128LUX)

Downloadable at M-System's web site.

A dedicated cable is required to connect the module to the PC. Please refer to the internet software download site or the users manual for the PC configurator for applicable cable types.

GENERAL SPECIFICATIONS

Connection

Voltage input: Connector type terminal block
(applicable wire size ≤ 2.5 dia, 0.5 - 3.5 mm²)

Current input: Screw terminal block
(applicable wire size ≤ 2.4 dia, 0.5 - 3.5 mm²)

Output, power: Connector type terminal block
(applicable wire size ≤ 2.4 dia, 0.5 - 2.5 mm²)



Configuration: Single phase/2-wire and 3-wire, 3-phase/3-wire balanced/unbalanced load, 3-phase/4-wire balanced/unbalanced load

Housing material: Flame-resistant resin (gray)

Mode selector: Select operation or configuration mode

Isolation: Voltage input to current input to discrete input to discrete output to network interface or configurator jack or analog output to power

• **Measured variables**

Voltage: 1 - N, 2 - N, 3 - N, 1 - 2, 2 - 3, 3 - 1

Current: 1, 2, 3, N

Active / reactive / apparent power: 1, 2, 3, Σ

Power factor: 1, 2, 3, Σ

Frequency

Voltage phase angle: 1 - 2, 2 - 3, 3 - 1

Active energy: Incoming / outgoing / high tariff (peak) / low tariff (off-peak)

Reactive energy: Incoming / outgoing / lag / lead / high tariff (peak) / low tariff (off-peak)

Apparent energy

Active / reactive / apparent average power (demand)

Average current: 1, 2, 3, N

Harmonic contents: Σ , 2nd to 31st

Count time: High tariff / low tariff

Max. and min. values

Demand history: 1 to 4

INPUT SPECIFICATIONS

Frequency: 50 / 60 Hz (45 - 65 Hz)

• **Voltage Input**

Rated voltage

Line-to-line (delta voltage): 480 V

Line-neutral (phase voltage): 277 V (single-phase / 2-wire and 3-wire)

Consumption VA: $\leq U_{LN}^2 / 300 \text{ k}\Omega$ / phase

Overload capacity: 200 % of rating for 10 sec., 120 % continuous

Selectable primary voltage range: 50 - 400 000 V

• **Current Input**

Rated current: 1 A or 5 A

Consumption VA: $\leq I^2 \cdot 0.01 \Omega$ / phase

Overload capacity: 4000 % of rating for 1 sec., 2000 % for 4 sec., 120 % continuous

Selectable primary current range: 1 - 20 000 A

Selectable primary power range: $\leq 2 \text{ G VA}$

Operational range

Voltage, current, apparent power: $\leq 120 \%$ of the rating

Active / reactive power: -120 to +120 % of the rating

Frequency: 45 - 65 Hz

Power factor: -1 to +1

■ **Contact Input:** 24 V DC or 110 V DC

(input resistance 6 k Ω)

Detecting voltage: External 24 V DC $\pm 10 \%$ or 110 V DC $\pm 10 \%$

ON current: $\geq 1 \text{ mA}$ ($\leq 24 \text{ k}\Omega$ @ 24 V, $\leq 110 \text{ k}\Omega$ @ 110 V)

OFF current: $\leq 0.1 \text{ mA}$ ($\geq 240 \text{ k}\Omega$ @ 24 V, $\geq 1.1 \text{ M}\Omega$ @ 110 V)

Detecting time: 10 - 1000 msec.

The status can be monitored on the Modbus; usable to reset energy count or to update average (demand) value.

OUTPUT SPECIFICATIONS

■ **Network Interface**

Communication: Half-duplex, asynchronous, no procedure

Interface: Conforms to EIA RS-485

Max. transmission distance: 500 meters

Baud rate: 1.2 - 38.4 kbps

Max. number of nodes: 31 (except the master)

Protocol: Modbus RTU

Node address: 1 - 247 (factory default setting: 1)

Parity: none, even or odd (factory default setting: odd)

Stop bit: 1 or 2 (factory default setting: 1)

Media: Shielded twisted-pair cable (CPEV-S 0.9 dia.)

■ **DC Current:** 4 - 20 mA DC

Load resistance: $\leq 270 \Omega$

Measurands converted into analog output: Voltage, Current, Active / reactive / apparent power, Power factor, Frequency, Harmonic contents

■ **DC Voltage:** 1 - 5 V DC

Load resistance: $\geq 5000 \Omega$

Measurands converted into analog output: Voltage, Current, Active / reactive / apparent power, Power factor, Frequency, Harmonic contents

■ **Open Collector**

Programmable for either alarm or energy count.

Max. rated load: 130 V DC @ 50 mA

Continuous rated load: 130 V DC @ 30 mA

Saturation voltage: 1.5 V DC

Measurands applicable to alarm: Voltage, current, average current (demand), neutral current, frequency, power, average power (demand)

(ON delay, deadband and other parameters are selectable)

Measurands applicable to count: Energy;

Pulse rate selectable within

0.1 - 10 000.0 kWh/p, kvarh/p, kVAh/p

INSTALLATION

Power input

• **AC:** $< 8 \text{ VA}$

• **DC:** Operational voltage range 99 - 264 V, ripple 10 %p-p max.; $< 3 \text{ W}$

Operating temperature: -10 to +55°C (14 to 131°F)

Operating humidity: 30 to 90 %RH (non-condensing)



Mounting: DIN rail
Weight: 320 g (0.71 lb)

IEC 62053-22: 2003 class 0.5s
IEC 62053-23: 2003 class 2
(IEC standards are applicable with Option /H only)

PERFORMANCE

Accuracy (at 23°C ±10°C or 73.4°F ±18°F, 45 - 65 Hz)

Voltage: ±0.3 % (±0.2 % for Option /H)*

Current: ±0.3 % (±0.2 % for Option /H)*

Power: ±0.5 %*

Power factor: ±0.5 %

Frequency: ±0.1 %*

Energy: ±1 % (±0.5 % for Option /H)

Harmonic contents: ±1 %*

Analog output: Accuracy of assigned measurand or ±0.2 %, whichever is greater.

*In percentage of the spans: 480 V for voltage, 1 A or 5 A for current, 4155 W (5 A) or 831 W (1 A) for active power. The described accuracy levels are ensured at the input 1 % or more for phase 2 current with 3-phase/3-wire unbalanced load, for neutral current with 3-phase/4-wire unbalanced load, and neutral current with 1-phase/3-wire.

Response time: ≤ 2 sec. (0 - 99 %),
≤ 3 sec. for frequency and harmonic contents

Sampling time:

Harmonic contents and frequency: ≤ 1.1 sec.

Other: ≤ 600 msec.

Insulation resistance: ≥ 100 MΩ with 500 V DC

Dielectric strength:

4000 V AC @1 minute

(voltage input or current input or discrete input or discrete output or network interface or configurator jack or analog output to power)

2500 V AC @1 minute

(voltage input to current input to discrete input to discrete output to network interface or configurator jack or analog output)

STANDARDS & APPROVALS

CE conformity:

EMC Directive (2004/108/EC)

EMI EN 61000-6-4: 2007

EMS EN 61000-6-2: 2005

Low Voltage Directive (2006/95/EC)

EN 61010-1: 2001

Measurement Category III (input)

Measurement Category II (output)

Installation Category II (power)

Pollution Degree 2

Input to power: Reinforced insulation (550 V)

Output to power: Reinforced insulation (300 V)

Input to output: Basic insulation (550 V)

IEC standard:



EXTERNAL VIEW

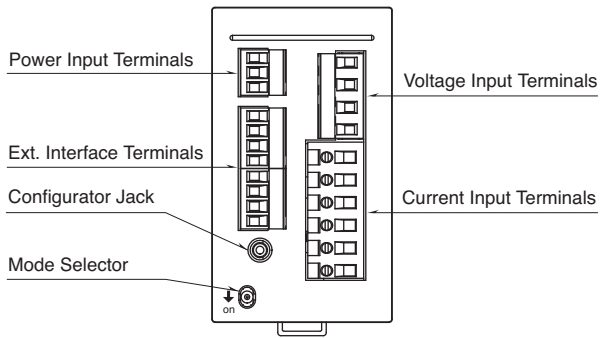

TERMINAL CONNECTIONS

■ EXTERNAL INTERFACE CODE: 1

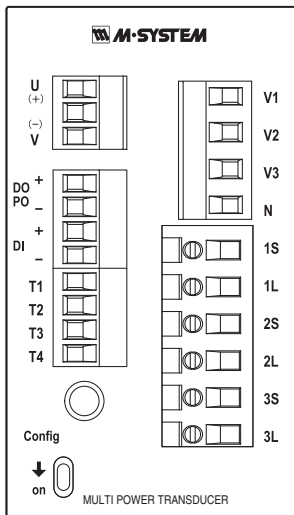

■ EXTERNAL INTERFACE CODE: 2, 3

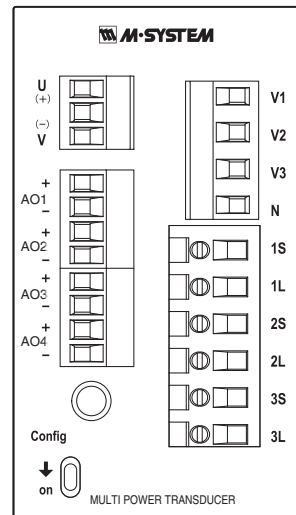

■ EXTERNAL INTERFACE CODE: 4, 5

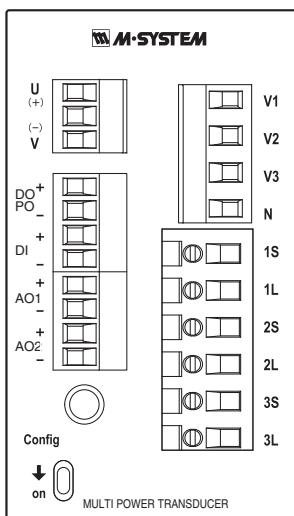

■ EXTERNAL INTERFACE CODE: 6, 7

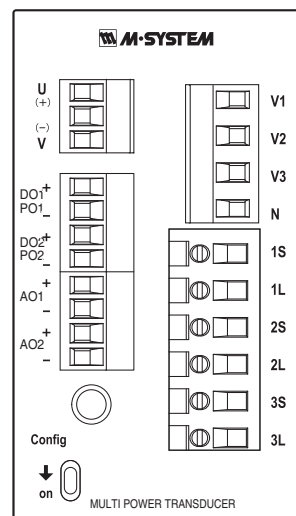

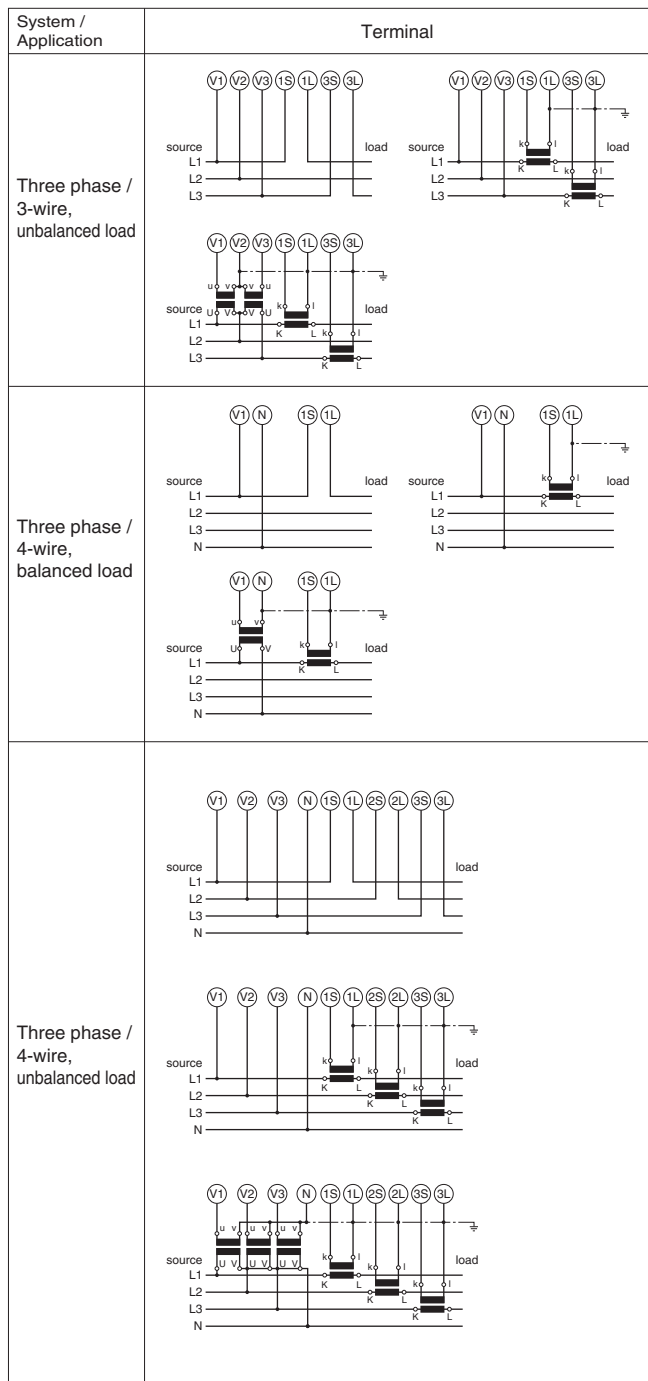
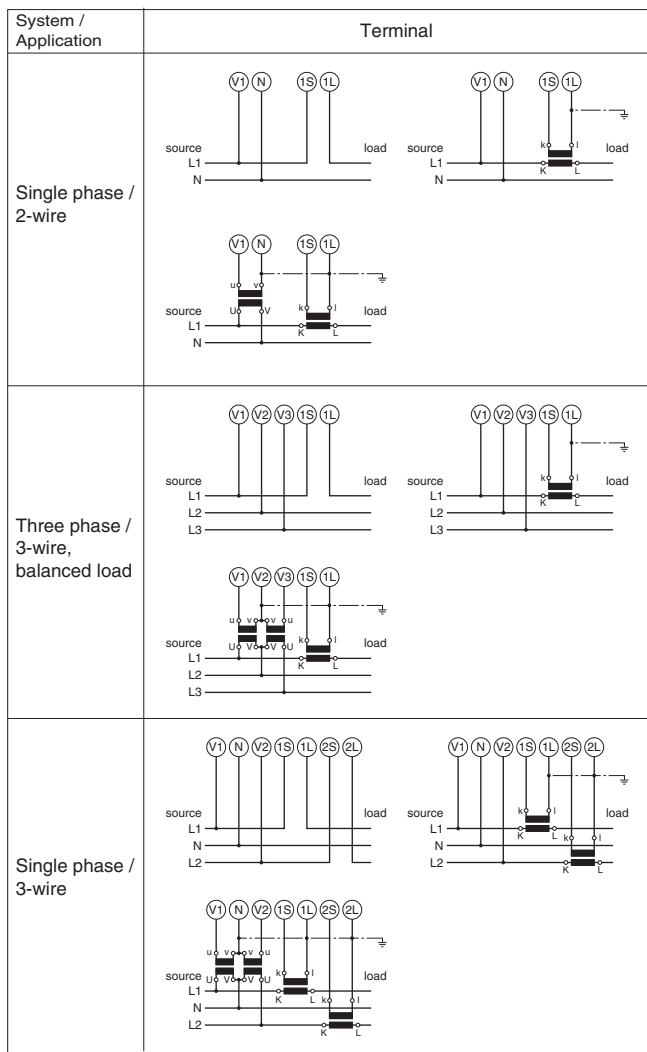

EXTERNAL INTERFACE CODE: 1

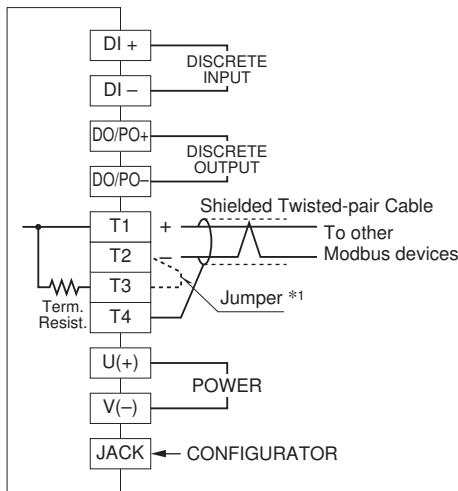

EXTERNAL INTERFACE CODE: 2,3

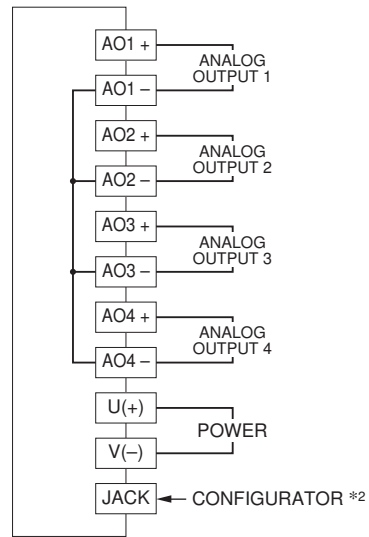

EXTERNAL INTERFACE CODE: 4, 5

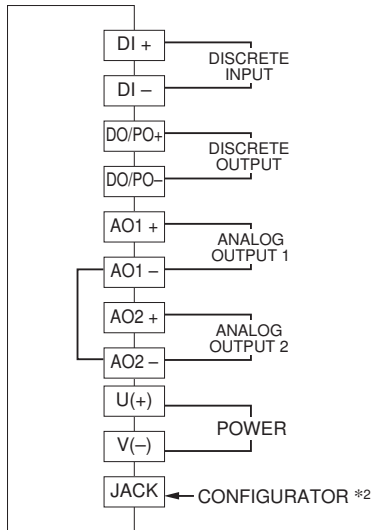

EXTERNAL INTERFACE CODE: 6, 7

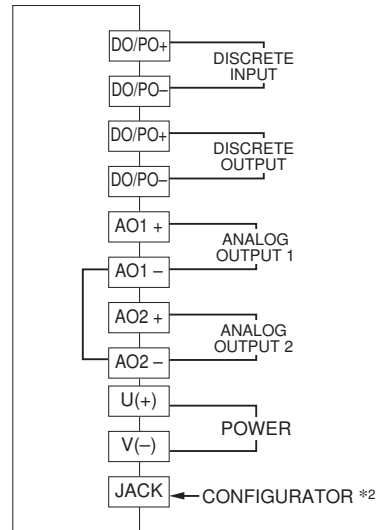

• Discrete Input Connection E.g. • Discrete Output Connection E.g.

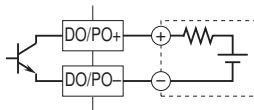
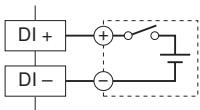

- *1. When the device is located at the end of a transmission line via twisted-pair cable, (when there is no cross-wiring), close across the terminal T2 –T3 with a leadwire. When the device is not at the end, no shortcircuit wire is required.
- *2. Analog output may momentarily fluctuate while the configurator cable is left connected.

MODBUS WIRING CONNECTION

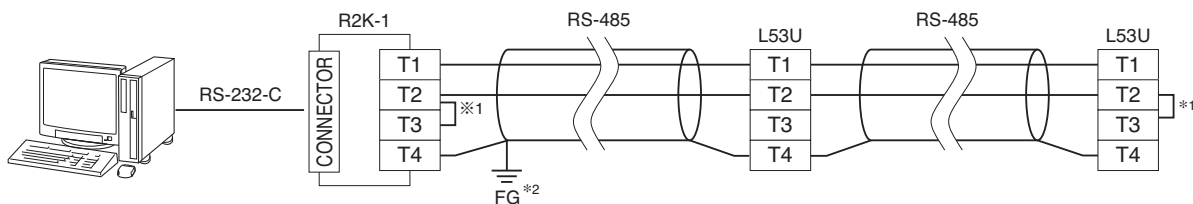

- *1. Internal terminating resistor is used when the device is at the end of a transmission line.
- *2. Install shield cables to all sections and ground them at single point.



DIMENSIONS unit: mm (inch)

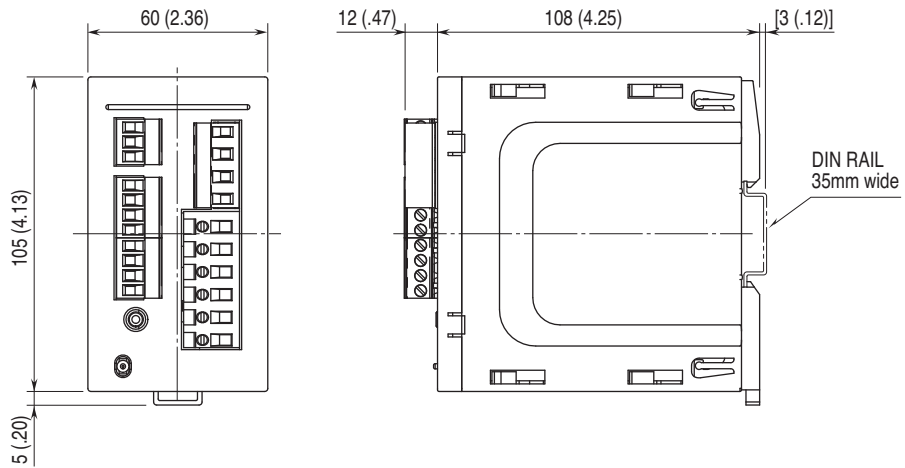

SYSTEM CONFIGURATION EXAMPLES

■ RS-485 / RS-232C

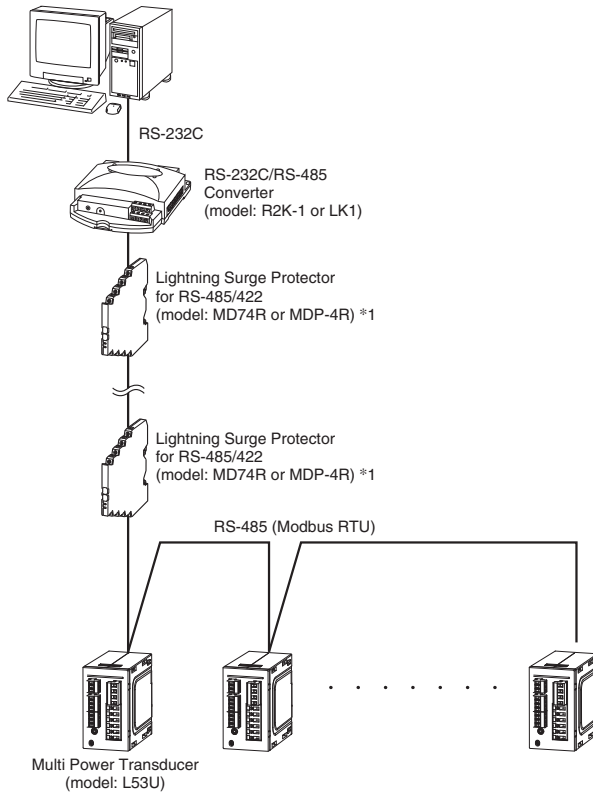

■ RS-485 / ETHERNET

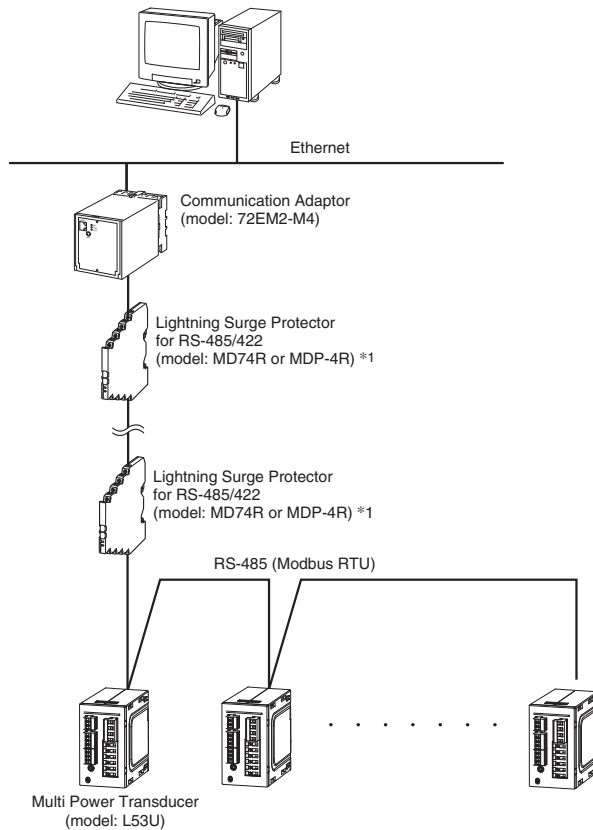

*1. Insert lightning surge protectors recommended in this example if necessary.





Specifications are subject to change without notice.



幸託有限公司
XIN TOP CORPORATION

TEL : (02)2598-1199
FAX : (02)2596-2331

E-mail : info@xintop.com
Website : www.xintop.com