

**Plug-in Signal Conditioners K-UNIT**

**ANALOG SUBTRACTOR**

(two isolated outputs)

**Functions & Features**

- Accepts two DC inputs and provides two isolated standard process signals proportional to the difference of the two signals
- Isolation up to 2000 V AC
- High-density mounting

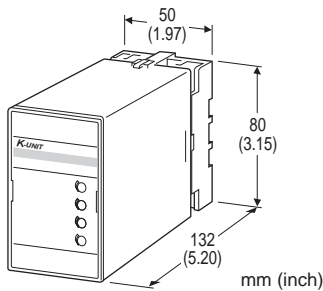

**MODEL: KWSBS-[1][2][3]-[4][5]**

**ORDERING INFORMATION**

- Code number: KWSBS-[1][2][3]-[4][5]
- Specify a code from below for each [1] through [5]. (e.g. KWSBS-6A6-B/Q)
- Special input and output ranges (For codes Z & 0)
- Parameters (e.g.  $K_1 = 2.00$ ,  $K_2 = 0.10$ )
- Specify the specification for option code /Q (e.g. /C01/S01)

When the user requires a current and a voltage output, specify the current to be the Output 1 which allows a greater load.

**[1] INPUT**

**Voltage**

- 1: 0 - 10 mV DC (Input resistance 10 k $\Omega$  min.)
- 15: 0 - 50 mV DC (Input resistance 10 k $\Omega$  min.)
- 16: 0 - 60 mV DC (Input resistance 10 k $\Omega$  min.)
- 2: 0 - 100 mV DC (Input resistance 100 k $\Omega$  min.)
- 3: 0 - 1 V DC (Input resistance 1 M $\Omega$  min.)
- 4: 0 - 10 V DC (Input resistance 1 M $\Omega$  min.)
- 5: 0 - 5 V DC (Input resistance 1 M $\Omega$  min.)
- 6: 1 - 5 V DC (Input resistance 1 M $\Omega$  min.)
- 4W: -10 - +10 V DC (Input resistance 1 M $\Omega$  min.)
- 5W: -5 - +5 V DC (Input resistance 1 M $\Omega$  min.)
- 0: Specify voltage (See INPUT SPECIFICATIONS)

**[2] OUTPUT 1**

**Current**

- A: 4 - 20 mA DC (Load resistance 600  $\Omega$  max.)
- B: 2 - 10 mA DC (Load resistance 1200  $\Omega$  max.)
- C: 1 - 5 mA DC (Load resistance 2400  $\Omega$  max.)
- D: 0 - 20 mA DC (Load resistance 600  $\Omega$  max.)
- E: 0 - 16 mA DC (Load resistance 750  $\Omega$  max.)
- F: 0 - 10 mA DC (Load resistance 1200  $\Omega$  max.)
- G: 0 - 1 mA DC (Load resistance 12 k $\Omega$  max.)
- Z: Specify current (See OUTPUT SPECIFICATIONS)

**Voltage**

- 1: 0 - 10 mV DC (Load resistance 10 k $\Omega$  min.)
- 2: 0 - 100 mV DC (Load resistance 100 k $\Omega$  min.)
- 3: 0 - 1 V DC (Load resistance 1000  $\Omega$  min.)
- 4: 0 - 10 V DC (Load resistance 10 k $\Omega$  min.)
- 5: 0 - 5 V DC (Load resistance 5000  $\Omega$  min.)
- 6: 1 - 5 V DC (Load resistance 5000  $\Omega$  min.)
- 4W: -10 - +10 V DC (Load resistance 10 k $\Omega$  min.)
- 5W: -5 - +5 V DC (Load resistance 5000  $\Omega$  min.)
- 0: Specify voltage (See OUTPUT SPECIFICATIONS)

**[3] OUTPUT 2**

**Current**

- A: 4 - 20 mA DC (Load resistance 350  $\Omega$  max.)
- B: 2 - 10 mA DC (Load resistance 700  $\Omega$  max.)
- C: 1 - 5 mA DC (Load resistance 1400  $\Omega$  max.)
- D: 0 - 20 mA DC (Load resistance 350  $\Omega$  max.)
- E: 0 - 16 mA DC (Load resistance 430  $\Omega$  max.)
- F: 0 - 10 mA DC (Load resistance 700  $\Omega$  max.)
- G: 0 - 1 mA DC (Load resistance 7000  $\Omega$  max.)
- Z: Specify current (See OUTPUT SPECIFICATIONS)

**Voltage**

Same range availability as Output 1

**[4] POWER INPUT**

**AC Power**

- B: 100 V AC
- C: 110 V AC
- D: 115 V AC
- F: 120 V AC
- G: 200 V AC
- H: 220 V AC
- J: 240 V AC

**DC Power**

- S: 12 V DC
- R: 24 V DC

**[5] OPTIONS**

- blank: none
- /Q: With options (specify the specification)



## SPECIFICATIONS OF OPTION: Q (multiple selections)

### COATING (For the detail, refer to M-System's web site.)

/C01: Silicone coating

/C02: Polyurethane coating

/C03: Rubber coating

### TERMINAL SCREW MATERIAL

/S01: Stainless steel

## GENERAL SPECIFICATIONS

**Construction:** Plug-in

**Connection:** M3.5 screw terminals

**Screw terminal:** Chromated steel (standard) or stainless steel

**Housing material:** Flame-resistant resin (black)

**Isolation:** Input 1 or input 2 to output 1 to output 2 to power

**Overrange output:** Approx. -10 to +120 % at 1 - 5 V

**Zero adjustment:** -5 to +5 % (front)

**Span adjustment:** 95 to 105 % (front)

**Equation:** Output =  $K_1 \times$  Input 1 -  $K_2 \times$  Input 2

( $K_1 \times$  Input 1 >  $K_2 \times$  Input 2)

$K_1, K_2$ : 0.10 - 2.00 (parameters)

Output, Input 1  $\times K_1$ , Input 2  $\times K_2$ : 0 - 100%

$K_1, K_2$  are ex-factory specified.

## INPUT SPECIFICATIONS

■ **DC Voltage:** -300 - +300 V DC

**Minimum span:** 3 mV

**Offset:** Max. 1.5 times span

**Input resistance**

Span 3 - 10 mV :  $\geq 10 \text{ k}\Omega$

Span 10 - 100 mV :  $\geq 10 \text{ k}\Omega$

Span 0.1 - 1 V :  $\geq 100 \text{ k}\Omega$

Span  $\geq 1 \text{ V}$  :  $\geq 1 \text{ M}\Omega$

## OUTPUT SPECIFICATIONS

■ **DC Current:** 0 - 20 mA DC

**Minimum span:** 1 mA

**Offset:** Max. 1.5 times span

**Load resistance:** Output drive 12 V max. for Output 1;

7 V max. for Output 2

■ **DC Voltage:** -10 - +12 V DC

**Minimum span:** 5 mV

**Offset:** Max. 1.5 times span

**Load resistance:** Output drive 1 mA max. at  $\geq 0.5 \text{ V}$

## INSTALLATION

**Power input**

•**AC:** Operational voltage range: rating  $\pm 10 \%$ ,  
50/60  $\pm 2$  Hz, approx. 3 VA

•**DC:** Operational voltage range: rating  $\pm 10 \%$

ripple 10 %p-p max., approx. 3 W (125 mA at 24 V)

**Operating temperature:** -5 to +55°C (23 to 131°F)

**Operating humidity:** 30 to 90 %RH (non-condensing)

**Mounting:** Surface or DIN rail

**Weight:** 400 g (0.88 lb)

## PERFORMANCE in percentage of span

**Accuracy:**  $\pm 0.2 \%$  ( $\pm 0.4 \%$  at  $K_1$  and/or  $K_2 > 1.00$ )

**Temp. coefficient:**  $\pm 0.02 \%$ /°C ( $\pm 0.01 \%$ /°F)

**Response time:**  $\leq 0.5 \text{ sec.}$  (0 - 90 %)

**Line voltage effect:**  $\pm 0.1 \%$  over voltage range

**Insulation resistance:**  $\geq 100 \text{ M}\Omega$  with 500 V DC

**Dielectric strength:** 2000 V AC @ 1 minute

(input to output to power to ground)

1000 V AC @ 1 minute (output 1 to output 2)



## DIMENSIONS unit: mm (inch)

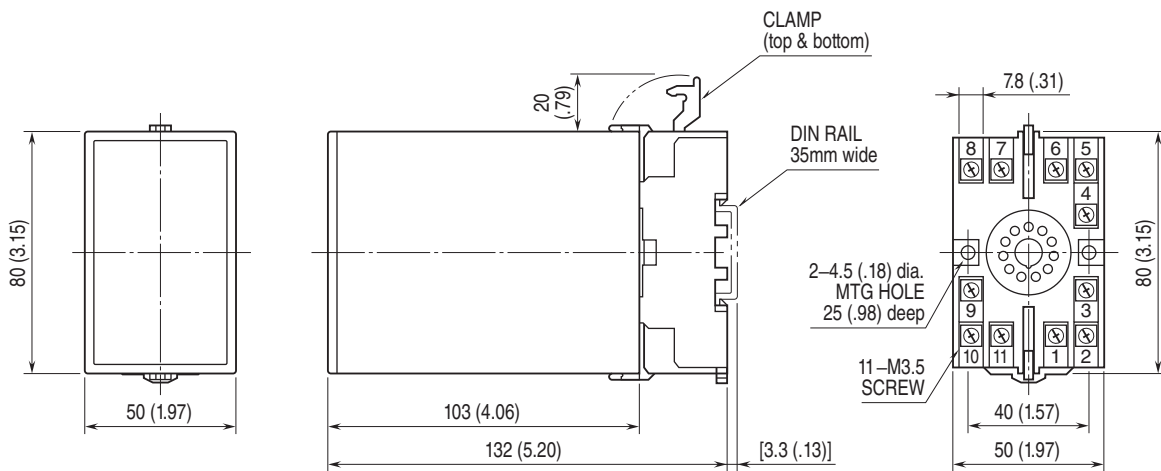

• When mounting, no extra space is needed between units.

## SCHEMATIC CIRCUITRY & CONNECTION DIAGRAM

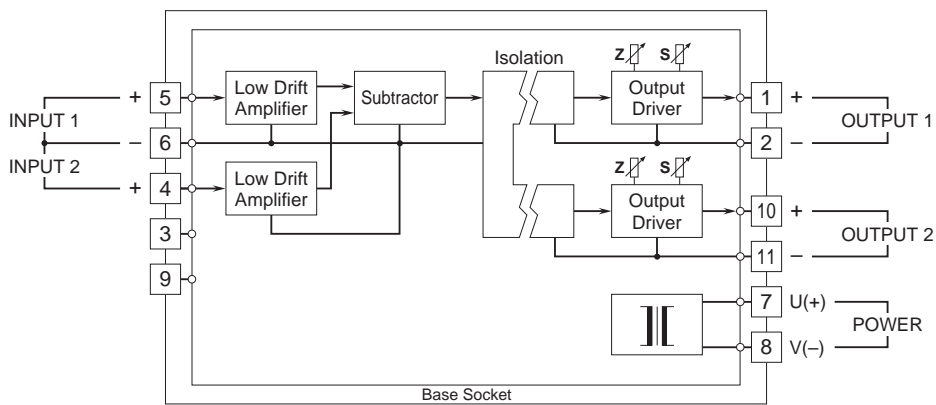

Specifications are subject to change without notice.