

Plug-in Signal Conditioners K-UNIT

RTD TRANSMITTER

(two isolated outputs)

Functions & Features

- Accepting direct input from an RTD and providing two standard process signals
- Linearization
- Burnout protection
- "Active bridge" circuit containing two constant current sources allows large leadwire resistances up to 200 Ω
- Fast response type available
- High-density mounting
- CE marking

Typical Applications

- Long distance transmission between the RTD and the transmitter
- Combination with intrinsic safety barriers

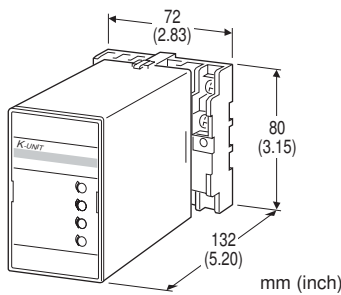

MODEL: KWRS2-[1][2][3]-[4][5]

ORDERING INFORMATION

• Code number: KWRS2-[1][2][3]-[4][5]
Specify a code from below for each [1] through [5].
(e.g. KWRS2-4AA-H/BL)

- Temperature range (e.g. 0 - 500°C)
- Special output ranges (For codes Z & 0)

When the user requires a current and a voltage output, specify the current to be the Output 1 which allows a greater load.

[1] INPUT RTD (2- or 3-wire)

- 1:** JPt 100 (JIS'89)
(Usable range: -200 to +500°C, -328 to +932°F; min.span: 50°C, 90°F)
- 3:** Pt 100 (JIS'89)
(Usable range: -200 to +650°C, -328 to +1202°F; min.span: 50°C, 90°F)
- 4:** Pt 100 (JIS'97, IEC)
(Usable range: -200 to +650°C, -328 to +1202°F; min.span: 50°C, 90°F)

5: Pt 50 Ω (JIS'81)

(Usable range: -200 to +500°C, -328 to +932°F; min.span: 100°C, 180°F)

6: Ni 508.4 Ω

(Usable range: -50 to +200°C, -58 to +392°F; min.span: 30°C, 54°F)

0: Specify

[2] OUTPUT 1

Current

- A:** 4 - 20 mA DC (Load resistance 600 Ω max.)
B: 2 - 10 mA DC (Load resistance 1200 Ω max.)
C: 1 - 5 mA DC (Load resistance 2400 Ω max.)
D: 0 - 20 mA DC (Load resistance 600 Ω max.)
E: 0 - 16 mA DC (Load resistance 750 Ω max.)
F: 0 - 10 mA DC (Load resistance 1200 Ω max.)
G: 0 - 1 mA DC (Load resistance 12 kΩ max.)
Z: Specify current (See OUTPUT SPECIFICATIONS)

Voltage

- 1:** 0 - 10 mV DC (Load resistance 10 kΩ min.)
2: 0 - 100 mV DC (Load resistance 100 kΩ min.)
3: 0 - 1 V DC (Load resistance 1000 Ω min.)
4: 0 - 10 V DC (Load resistance 10 kΩ min.)
5: 0 - 5 V DC (Load resistance 5000 Ω min.)
6: 1 - 5 V DC (Load resistance 5000 Ω min.)
0: Specify voltage (See OUTPUT SPECIFICATIONS)

[3] OUTPUT 2

Current

- A:** 4 - 20 mA DC (Load resistance 350 Ω max.)
B: 2 - 10 mA DC (Load resistance 700 Ω max.)
C: 1 - 5 mA DC (Load resistance 1400 Ω max.)
D: 0 - 20 mA DC (Load resistance 350 Ω max.)
E: 0 - 16 mA DC (Load resistance 430 Ω max.)
F: 0 - 10 mA DC (Load resistance 700 Ω max.)
G: 0 - 1 mA DC (Load resistance 7000 Ω max.)
Z: Specify current (See OUTPUT SPECIFICATIONS)

Voltage

Same range availability as Output 1

[4] POWER INPUT

AC Power

- G:** 200 V AC
H: 220 V AC
J: 240 V AC

DC Power

- S:** 12 V DC
R: 24 V DC

[5] OPTIONS (multiple selections)

Response Time (0 - 90 %)

blank: Standard (≤ 0.5 sec.)



/K: Fast Response (Approx. 25 msec.)

Burnout

blank: Upscale burnout

/BL: Downscale burnout

1350 V AC @ 1 minute (input to output)

1000 V AC @ 1 minute (output 1 to output 2)

GENERAL SPECIFICATIONS

Construction: Plug-in

Connection: M3.5 screw terminals

Housing material: Flame-resistant resin (black)

Isolation: Input to output 1 to output 2 to power

Overrange output: Approx. -10 to +120 % at 1 - 5 V

Zero adjustment: -5 to +5 % (front)

Span adjustment: 95 to 105 % (front)

Linearization: Standard

STANDARDS & APPROVALS

CE conformity:

EMC Directive (2004/108/EC)

EMI EN 61000-6-4: 2007

EMS EN 61000-6-2: 2005

Low Voltage Directive (2006/95/EC)

EN 61010-1: 2001

Installation Category II

Pollution Degree 2

Input or output to power: Reinforced insulation (300 V)

Input to output: Basic insulation (300 V)

INPUT SPECIFICATIONS

Input: 2- or 3-wire RTDs

Maximum leadwire resistance: 200 Ω per wire (3-wire)

Sensing current: 2 mA

OUTPUT SPECIFICATIONS

■ DC Current: 0 - 20 mA DC

Minimum span: 1 mA

Offset: Max. 1.5 times span

Load resistance: Output drive 12 V max. for Output 1;

7 V max. for Output 2

■ DC Voltage: -10 - +12 V DC

Minimum span: 5 mV

Offset: Max. 1.5 times span

Load resistance: Output drive 1 mA max. at ≥ 0.5 V

INSTALLATION

Power input

•AC: Operational voltage range: rating ± 10 %, 50/60 ± 2 Hz, approx. 3 VA

•DC: Operational voltage range: rating ± 10 % ripple 10 %p-p max., approx. 3 W (125 mA at 24 V)

Operating temperature: -5 to +55°C (23 to 131°F)

Operating humidity: 30 to 90 %RH (non-condensing)

Mounting: Surface or DIN rail

Weight: 400 g (0.88 lbs)

PERFORMANCE in percentage of span

Accuracy: ± 0.2 %

Temp. coefficient: ± 0.02 %/°C (± 0.01 %/°F)

Burnout response: ≤ 10 sec.

Line voltage effect: ± 0.1 % over voltage range

Insulation resistance: ≥ 100 M Ω with 500 V DC

Dielectric strength: 2300 V AC @ 1 minute

(input or output to power to ground)



EXTERNAL DIMENSIONS & TERMINAL ASSIGNMENTS unit: mm (inch)

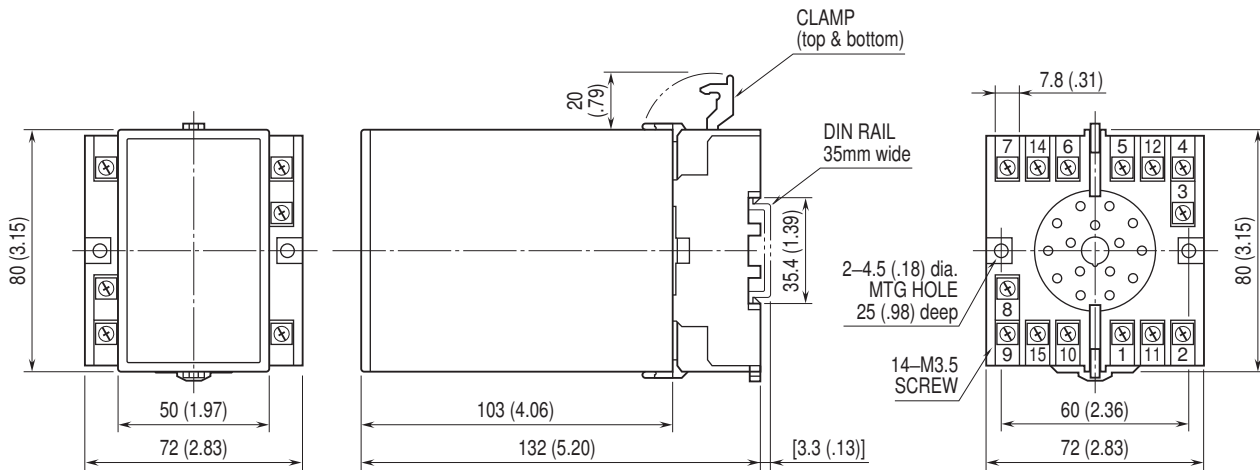

• When mounting, no extra space is needed between units.

SCHEMATIC CIRCUITRY & CONNECTION DIAGRAM

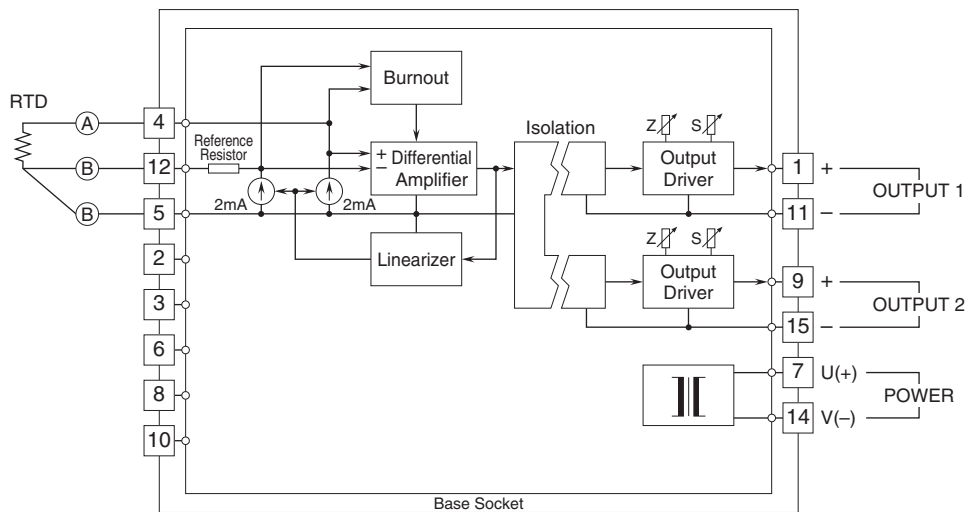

Specifications are subject to change without notice.