

## Plug-in Signal Conditioners K-UNIT

### REVERSE TRANSMITTER

#### Functions & Features

- Providing a reversed output proportional to the input signal
- High-density mounting

#### Typical Applications

- Matching manipulating signal with the valve action

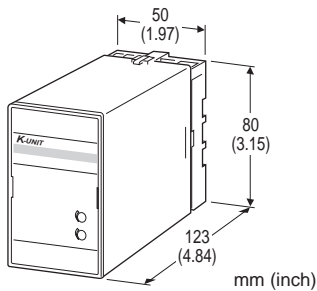

### MODEL: KUS-[1][2]-[3][4]

#### ORDERING INFORMATION

- Code number: KUS-[1][2]-[3][4]
- Specify a code from below for each [1] through [4]. (e.g. KUS-6A-B/Q)
- Special input and output ranges (For codes Z & 0)
- Specify the specification for option code /Q (e.g. /C01/S01)

#### [1] INPUT

##### Current

- A: 4 - 20 mA DC (Input resistance 250 Ω)
- A1: 4 - 20 mA DC (Input resistance 50 Ω)
- B: 2 - 10 mA DC (Input resistance 500 Ω)
- C: 1 - 5 mA DC (Input resistance 1000 Ω)
- D: 0 - 20 mA DC (Input resistance 50 Ω)
- E: 0 - 16 mA DC (Input resistance 62.5 Ω)
- F: 0 - 10 mA DC (Input resistance 100 Ω)
- G: 0 - 1 mA DC (Input resistance 1000 Ω)
- H: 10 - 50 mA DC (Input resistance 100 Ω)
- J: 0 - 10 μA DC (Input resistance 1000 Ω)
- K: 0 - 100 μA DC (Input resistance 1000 Ω)
- GW: -1 - +1 mA DC (Input resistance 1000 Ω)
- FW: -10 - +10 mA DC (Input resistance 100 Ω)
- Z: Specify current (See INPUT SPECIFICATIONS)

##### Voltage

- 1: 0 - 10 mV DC (Input resistance 10 kΩ min.)
- 15: 0 - 50 mV DC (Input resistance 10 kΩ min.)

- 16: 0 - 60 mV DC (Input resistance 10 kΩ min.)
- 2: 0 - 100 mV DC (Input resistance 100 kΩ min.)
- 3: 0 - 1 V DC (Input resistance 1 MΩ min.)
- 4: 0 - 10 V DC (Input resistance 1 MΩ min.)
- 5: 0 - 5 V DC (Input resistance 1 MΩ min.)
- 6: 1 - 5 V DC (Input resistance 1 MΩ min.)
- 4W: -10 - +10 V DC (Input resistance 1 MΩ min.)
- 5W: -5 - +5 V DC (Input resistance 1 MΩ min.)
- 0: Specify voltage (See INPUT SPECIFICATIONS)

#### [2] OUTPUT

##### Current

- A: 20 - 4 mA DC (Load resistance 750 Ω max.)
- B: 10 - 2 mA DC (Load resistance 1500 Ω max.)
- C: 5 - 1 mA DC (Load resistance 3000 Ω max.)
- D: 20 - 0 mA DC (Load resistance 750 Ω max.)
- E: 16 - 0 mA DC (Load resistance 900 Ω max.)
- F: 10 - 0 mA DC (Load resistance 1500 Ω max.)
- G: 1 - 0 mA DC (Load resistance 15 kΩ max.)
- Z: Specify current (See OUTPUT SPECIFICATIONS)

##### Voltage

- 1: 10 - 0 mV DC (Load resistance 10 kΩ min.)
- 2: 100 - 0 mV DC (Load resistance 100 kΩ min.)
- 3: 1 - 0 V DC (Load resistance 100 Ω min.)
- 4: 10 - 0 V DC (Load resistance 1000 Ω min.)
- 5: 5 - 0 V DC (Load resistance 500 Ω min.)
- 6: 5 - 1 V DC (Load resistance 500 Ω min.)
- 4W: +10 - -10 V DC (Load resistance 2000 Ω min.)
- 5W: +5 - -5 V DC (Load resistance 1000 Ω min.)
- 0: Specify voltage (See OUTPUT SPECIFICATIONS)

#### [3] POWER INPUT

##### AC Power

- B: 100 V AC
- C: 110 V AC
- D: 115 V AC
- F: 120 V AC
- G: 200 V AC
- H: 220 V AC
- J: 240 V AC

##### DC Power

- S: 12 V DC
- R: 24 V DC

#### [4] OPTIONS

- blank: none
- /Q: With options (specify the specification)



## SPECIFICATIONS OF OPTION: Q (multiple selections)

### COATING (For the detail, refer to M-System's web site.)

/C01: Silicone coating

/C02: Polyurethane coating

/C03: Rubber coating

### TERMINAL SCREW MATERIAL

/S01: Stainless steel

## GENERAL SPECIFICATIONS

Construction: Plug-in

Connection: M3.5 screw terminals

Screw terminal: Chromated steel (standard) or stainless steel

Housing material: Flame-resistant resin (black)

Isolation: Input to output to power

Overrange output: Approx. -10 to +120 % at 5 - 1 V

Zero adjustment: -5 to +5 % (front)

Span adjustment: 95 to 105 % (front)

## INPUT SPECIFICATIONS

### ■ DC Current:

Shunt resistor attached to the input terminals (0.5 W)

Specify input resistance value for code Z.

### ■ DC Voltage: -300 - +300 V DC

Minimum span: 3 mV

Offset: Max. 1.5 times span

### Input resistance

Span 3 - 10 mV :  $\geq 10 \text{ k}\Omega$

Span 10 - 100 mV :  $\geq 10 \text{ k}\Omega$

Span 0.1 - 1 V :  $\geq 100 \text{ k}\Omega$

Span  $\geq 1 \text{ V}$  :  $\geq 1 \text{ M}\Omega$

## OUTPUT SPECIFICATIONS

### ■ DC Current: 0 - 20 mA DC

Minimum span: 1 mA

Offset: Max. 1.5 times span

Load resistance: Output drive 15 V max.

### ■ DC Voltage: -10 - +12 V DC

Minimum span: 5 mV

Offset: Max. 1.5 times span

Load resistance: Output drive 10 mA max.; 5 mA for negative voltage output; at  $\geq 0.5 \text{ V}$

## INSTALLATION

### Power input

•AC: Operational voltage range: rating  $\pm 10 \%$ ,  
50/60  $\pm 2$  Hz, approx. 2 VA

•DC: Operational voltage range: rating  $\pm 10 \%$ ,  
ripple 10 %p-p max., approx. 2 W (90 mA at 24 V)

Operating temperature: -5 to +55°C (23 to 131°F)

Operating humidity: 30 to 90 %RH (non-condensing)

Mounting: Surface or DIN rail

Weight: 400 g (0.88 lb)

## PERFORMANCE in percentage of span

Accuracy:  $\pm 0.1 \%$

Temp. coefficient:  $\pm 0.02 \text{ }^\circ\text{C}$  ( $\pm 0.01 \text{ }^\circ\text{F}$ )

Response time:  $\leq 0.5 \text{ sec.}$  (0 - 90 %)

Line voltage effect:  $\pm 0.1 \%$  over voltage range

Insulation resistance:  $\geq 100 \text{ M}\Omega$  with 500 V DC

Dielectric strength: 2000 V AC @1 minute (input to output to power to ground)



## DIMENSIONS unit: mm (inch)

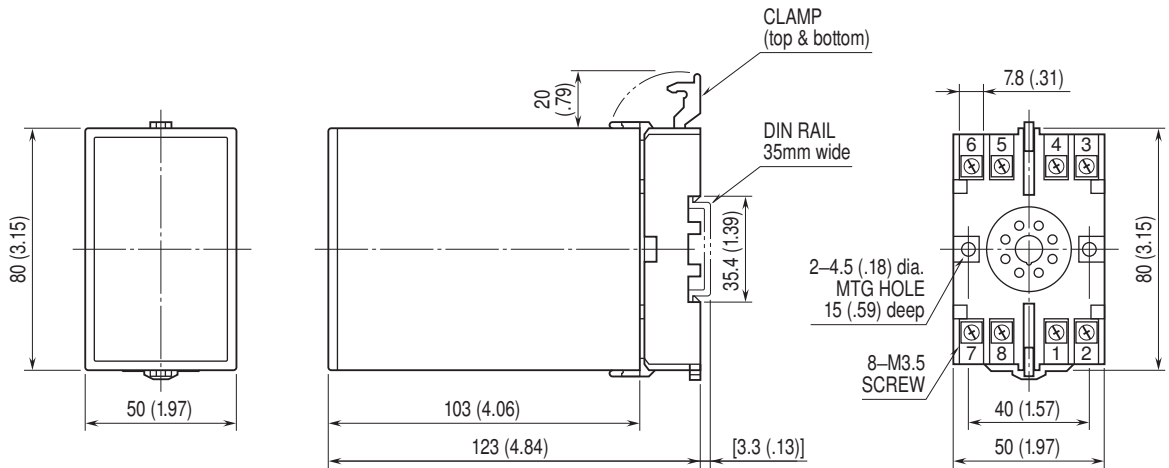

• When mounting, no extra space is needed between units.

## TERMINAL ASSIGNMENTS unit: mm (inch)

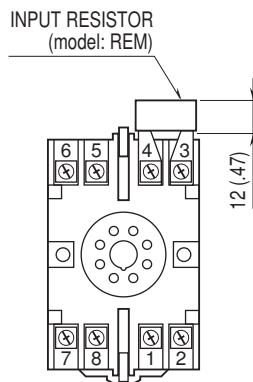

Input shunt resistor attached for current input.

## SCHEMATIC CIRCUITRY & CONNECTION DIAGRAM

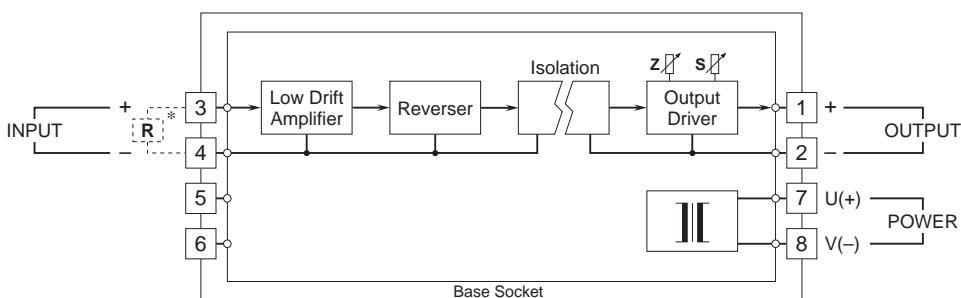

\*Input shunt resistor attached for current input.



Specifications are subject to change without notice.