

Plug-in Signal Conditioners K-UNIT

LOW FREQUENCY TRANSMITTER

(50 Hz minimum, for Mitsubishi inverter)

Functions & Features

- Converting the pulse output from FM terminal of Mitsubishi inverter into standard process signal
- Isolation up to 2000 V AC
- High-density mounting

Typical Applications

- Positive displacement flowmeters, turbine flowmeters and vortex flowmeters
- Proximity switches

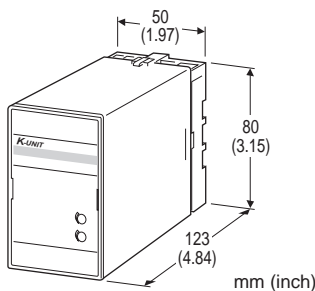

MODEL: KSP-2[1]-[2]-ME

ORDERING INFORMATION

- Code number: KSP-2[1]-[2]-ME
- Specify a code from below for each [1] and [2].
(e.g. KSP-2A-B-ME)
- Frequency range (e.g. 0 - 1440 Hz)

INPUT

2: Voltage pulse

[1] OUTPUT

Current

- A: 4 - 20 mA DC (Load resistance 750 Ω max.)
- B: 2 - 10 mA DC (Load resistance 1500 Ω max.)
- C: 1 - 5 mA DC (Load resistance 3000 Ω max.)
- D: 0 - 20 mA DC (Load resistance 750 Ω max.)
- E: 0 - 16 mA DC (Load resistance 900 Ω max.)
- F: 0 - 10 mA DC (Load resistance 1500 Ω max.)
- G: 0 - 1 mA DC (Load resistance 15 kΩ max.)
- Z: Specify current (See OUTPUT SPECIFICATIONS)

Voltage

- 1: 0 - 10 mV DC (Load resistance 10 kΩ min.)
- 2: 0 - 100 mV DC (Load resistance 100 kΩ min.)
- 3: 0 - 1 V DC (Load resistance 100 Ω min.)

- 4: 0 - 10 V DC (Load resistance 1000 Ω min.)
- 5: 0 - 5 V DC (Load resistance 500 Ω min.)
- 6: 1 - 5 V DC (Load resistance 500 Ω min.)
- 4W: -10 - +10 V DC (Load resistance 2000 Ω min.)
- 5W: -5 - +5 V DC (Load resistance 1000 Ω min.)
- 0: Specify voltage (See OUTPUT SPECIFICATIONS)

[2] POWER INPUT

AC Power

- B: 100 V AC
- C: 110 V AC
- D: 115 V AC
- F: 120 V AC
- G: 200 V AC
- H: 220 V AC
- J: 240 V AC

DC Power

- S: 12 V DC
- R: 24 V DC

GENERAL SPECIFICATIONS

Construction: Plug-in

Connection: M3.5 screw terminals

Housing material: Flame-resistant resin (black)

Isolation: Input to output to power

Overrange output: 0 to 120 % at 1 - 5 V

Zero adjustment: -5 to +5 % (front)

Span adjustment: 95 to 105 % (front)

Input pulse sensing: DC coupled standard

Input filter: CR filter incorporated

(C = 3.3 nF, R = 10 kΩ; parallel connection)

Low-end cutout: 2 to 5 %

Applicable inverter:

Mitsubishi electric FREQROL series: A024, A200, A500, A700, A800, D700, E500, E700, F400, F500, F700, F700PJ, F800, S500, U100, B, B3

Mitsubishi electric MELTRAC series: A100, A200, V200

(Note) Do NOT connect other devices except the transmitter to the inverter's FM terminal. Do NOT bundle the FM and motor wirings.

INPUT SPECIFICATIONS

Frequency range: 0 - 50 Hz through 0 - 1440 Hz

Pulse width (time) requirement: ≥ 280 μsec. (Hi and Lo)

■ Voltage Pulse

Waveform: Square

Input amplitude: V_H 4 ± 0.7 - 50 V, V_L 1 ± 0.7 V

Input impedance: ≥ 7 kΩ (for 9 V DC pulse)



OUTPUT SPECIFICATIONS

- **DC Current:** 0 - 20 mA DC
- Minimum span:** 1 mA
- Offset:** Max. 1.5 times span
- Load resistance:** Output drive 15 V max.
- **DC Voltage:** -10 - +12 V DC
- Minimum span:** 5 mV
- Offset:** Max. 1.5 times span
- Load resistance:** Output drive 10 mA max.; 5 mA for negative voltage output; at ≥ 0.5 V

INSTALLATION

Power input

- **AC:** Operational voltage range: rating ± 10 %, 50/60 ± 2 Hz, approx. 2.5 VA
- **DC:** Operational voltage range: rating ± 10 %, ripple 10% p-p max.; approx. 2.5 W (100 mA at 24 V)
- Operating temperature:** -5 to +55°C (23 to 131°F)
- Operating humidity:** 30 to 90 %RH (non-condensing)
- Mounting:** Surface or DIN rail
- Weight:** 350 g (0.77 lb)

PERFORMANCE in percentage of span

- Accuracy:** ± 0.3 % (output 10 - 100 %)
- Temp. coefficient:** ± 0.02 %/°C (± 0.01 %/°F)
- Response time:** (0 - 90 %)
- Approx. 2 sec. for 0 - 50 Hz
- Approx. 1 sec. for 0 - 100 Hz
- Approx. 0.5 sec. for 0 - 500 Hz
- Approx. 0.5 sec. for 0 - 10 kHz
- Ripple:** 0.2 %p-p max. with input ≥ 10 %
- Line voltage effect:** ± 0.1 % over voltage range
- Insulation resistance:** ≥ 100 M Ω with 500 V DC
- Dielectric strength:** 2000 V AC @1 minute (input to output to power to ground)

DIMENSIONS unit: mm (inch)

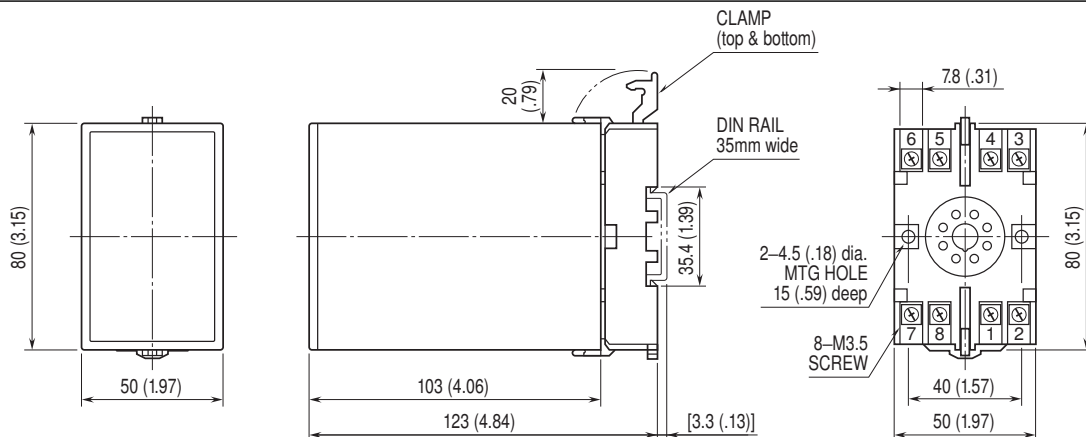

• When mounting, no extra space is needed between units.



SCHEMATIC CIRCUITRY & CONNECTION DIAGRAM

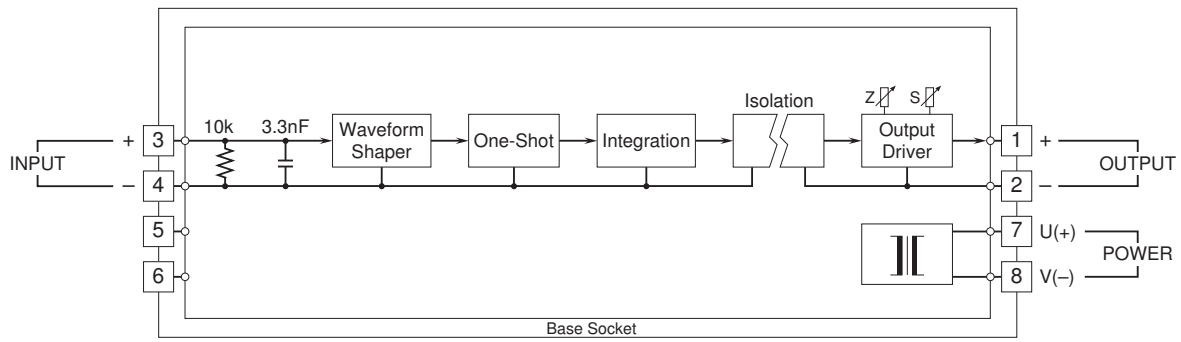

Note) Do NOT connect other devices except the transmitter to the inverter's FM terminal.
Do NOT bundle the FM and motor wirings.



Specifications are subject to change without notice.

