

Plug-in Signal Conditioners K-UNIT

SIGNAL TRANSMITTER

(high speed response)

Functions & Features

- Converting a DC input into a standard process signal
- Isolation between input and output
- 500 μsec. response
- High-density mounting

Typical Applications

- Isolation for a vibration analyzing system

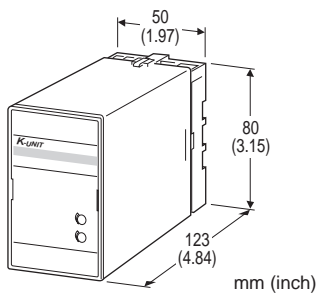

MODEL: KSF-[1][2]-[3][4]

ORDERING INFORMATION

- Code number: KSF-[1][2]-[3][4]
- Specify a code from below for each [1] through [4].
(e.g. KSF-6A-B/Q)
- Special input and output ranges (For codes Z & 0)
- Specify the specification for option code /Q
(e.g. /C01/S01)

[1] INPUT

Current

- A: 4 - 20 mA DC (Input resistance 250 Ω)
- B: 2 - 10 mA DC (Input resistance 500 Ω)
- C: 1 - 5 mA DC (Input resistance 1000 Ω)
- D: 0 - 20 mA DC (Input resistance 50 Ω)
- E: 0 - 16 mA DC (Input resistance 62.5 Ω)
- F: 0 - 10 mA DC (Input resistance 100 Ω)
- G: 0 - 1 mA DC (Input resistance 1000 Ω)
- H: 10 - 50 mA DC (Input resistance 100 Ω)
- GW: -1 - +1 mA DC (Input resistance 1000 Ω)
- FW: -10 - +10 mA DC (Input resistance 100 Ω)
- Z: Specify current (See INPUT SPECIFICATIONS)

Voltage

- 3: 0 - 1 V DC (Input resistance 1 MΩ min.)
- 4: 0 - 10 V DC (Input resistance 1 MΩ min.)
- 5: 0 - 5 V DC (Input resistance 1 MΩ min.)

- 6: 1 - 5 V DC (Input resistance 1 MΩ min.)
- 4W: -10 - +10 V DC (Input resistance 1 MΩ min.)
- 5W: -5 - +5 V DC (Input resistance 1 MΩ min.)
- 0: Specify voltage (See INPUT SPECIFICATIONS)

[2] OUTPUT

Current

- A: 4 - 20 mA DC (Load resistance 750 Ω max.)
- B: 2 - 10 mA DC (Load resistance 1500 Ω max.)
- C: 1 - 5 mA DC (Load resistance 3000 Ω max.)
- D: 0 - 20 mA DC (Load resistance 750 Ω max.)
- E: 0 - 16 mA DC (Load resistance 900 Ω max.)
- F: 0 - 10 mA DC (Load resistance 1500 Ω max.)
- G: 0 - 1 mA DC (Load resistance 15 kΩ max.)
- Z: Specify current (See OUTPUT SPECIFICATIONS)

Voltage

- 1: 0 - 10 mV DC (Load resistance 10 kΩ min.)
- 2: 0 - 100 mV DC (Load resistance 100 kΩ min.)
- 3: 0 - 1 V DC (Load resistance 1000 Ω min.)
- 4: 0 - 10 V DC (Load resistance 10 kΩ min.)
- 5: 0 - 5 V DC (Load resistance 5000 Ω min.)
- 6: 1 - 5 V DC (Load resistance 5000 Ω min.)
- 4W: -10 - +10 V DC (Load resistance 10 kΩ min.)
- 5W: -5 - +5 V DC (Load resistance 5000 Ω min.)
- 0: Specify voltage (See OUTPUT SPECIFICATIONS)

[3] POWER INPUT

AC Power

- B: 100 V AC
- C: 110 V AC
- D: 115 V AC
- F: 120 V AC
- G: 200 V AC
- H: 220 V AC
- J: 240 V AC

DC Power

- S: 12 V DC
- R: 24 V DC

[4] OPTIONS

- blank: none
- /Q: With options (specify the specification)

SPECIFICATIONS OF OPTION: Q (multiple selections)

- COATING (For the detail, refer to M-System's web site.)**
- /C01: Silicone coating
- /C02: Polyurethane coating
- /C03: Rubber coating
- TERMINAL SCREW MATERIAL**
- /S01: Stainless steel



GENERAL SPECIFICATIONS

(input or output or power to ground)

Construction: Plug-in
Connection: M3.5 screw terminals
Screw terminal: Chromated steel (standard) or stainless steel
Housing material: Flame-resistant resin (black)
Isolation: Input to output to power
Overrange output: Approx. -10 to +120 % at 1 - 5 V
Zero adjustment: -5 to +5 % (front)
Span adjustment: 95 to 105 % (front)

INPUT SPECIFICATIONS

■ **DC Current:**
 Shunt resistor attached to the input terminals (0.5 W)
 Specify input resistance value for code Z.
 ■ **DC Voltage:** -300 - +300 V DC
Minimum span: 1 V
Offset: Max. 1.5 times span
Input resistance: $\geq 1 \text{ M}\Omega$

OUTPUT SPECIFICATIONS

■ **DC Current:** 0 - 20 mA DC
Minimum span: 1 mA
Offset: Max. 1.5 times span
Load resistance: Output drive 15 V max.
 ■ **DC Voltage:** -10 - +12 V DC
Minimum span: 5 mV
Offset: Max. 1.5 times span
Load resistance: Output drive 1 mA max.; at $\geq 0.5 \text{ V}$

INSTALLATION

Power input
 •**AC:** Operational voltage range: rating $\pm 10 \%$,
 50/60 ± 2 Hz, approx. 2 VA
 •**DC:** Operational voltage range: rating $\pm 10 \%$,
 ripple 10 %p-p max., approx. 2 W (80 mA at 24 V)
Operating temperature: -5 to +55°C (23 to 131°F)
Operating humidity: 30 to 90 %RH (non-condensing)
Mounting: Surface or DIN rail
Weight: 400 g (0.88 lb)

PERFORMANCE in percentage of span

Accuracy: $\pm 0.1 \%$
Temp. coefficient: $\pm 0.02 \%/^{\circ}\text{C}$ ($\pm 0.01 \%/^{\circ}\text{F}$)
Response time: $\leq 500 \mu\text{sec.}$ (0 - 90 %)
Line voltage effect: $\pm 0.1 \%$ over voltage range
Insulation resistance: $\geq 100 \text{ M}\Omega$ with 500 V DC
Dielectric strength: 1000 V AC @1 minute
 (input to output to power)
 2000 V AC @1 minute



DIMENSIONS unit: mm (inch)

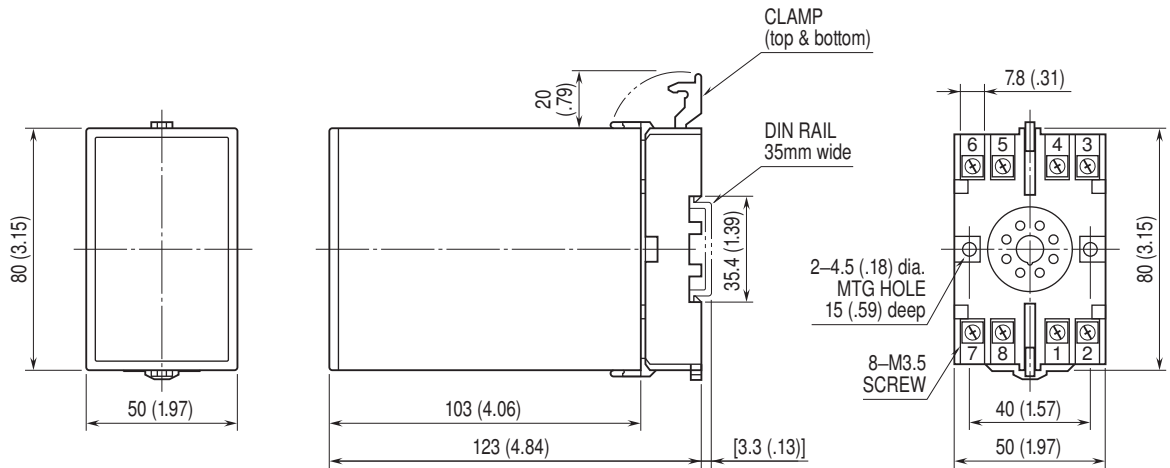

• When mounting, no extra space is needed between units.

TERMINAL ASSIGNMENTS unit: mm (inch)

INPUT RESISTOR
(model: REM)

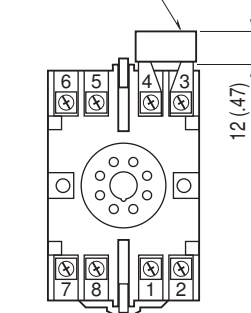

Input shunt resistor attached
for current input.

SCHEMATIC CIRCUITRY & CONNECTION DIAGRAM

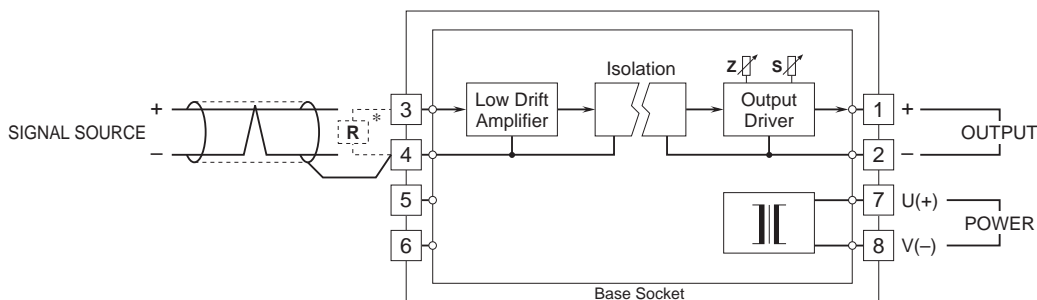

*Input shunt resistor attached for current input.

Remark: The unit, due to its fast-response design, does not eliminate noises included in the input signal. Use shielded twisted-pair cable for preventing them.



Specifications are subject to change without notice.