

Plug-in Signal Conditioners K-UNIT

DC ALARM

Functions & Features

- Providing relay contact closures at preset DC input levels
- Dual (Hi/Lo) trip
- Multi-turn screwdriver setpoint adjustments
- Monitor jacks provided for setpoint adjustments
- Enclosed relays
- Relays can be powered 110 V DC
- High-density mounting
- CE marking

Typical Applications

- Annunciator
- Various alarm applications

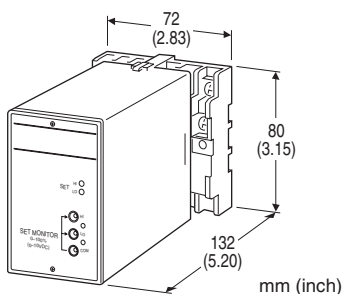

MODEL: KS2-[1]5-[2]

ORDERING INFORMATION

- Code number: KS2-[1]5-[2]
- Specify a code from below for each [1] and [2].
(e.g. KS2-65-H)
- Special input range (For codes Z & 0)

[1] INPUT

Current

- A: 4 - 20 mA DC (Input resistance 250 Ω)
- A1: 4 - 20 mA DC (Input resistance 50 Ω)
- B: 2 - 10 mA DC (Input resistance 500 Ω)
- C: 1 - 5 mA DC (Input resistance 1000 Ω)
- D: 0 - 20 mA DC (Input resistance 50 Ω)
- E: 0 - 16 mA DC (Input resistance 62.5 Ω)
- F: 0 - 10 mA DC (Input resistance 100 Ω)
- G: 0 - 1 mA DC (Input resistance 1000 Ω)
- H: 10 - 50 mA DC (Input resistance 100 Ω)
- K: 0 - 100 μA DC (Input resistance 1000 Ω)
- GW: -1 - +1 mA DC (Input resistance 1000 Ω)
- FW: -10 - +10 mA DC (Input resistance 100 Ω)
- Z: Specify current (See INPUT SPECIFICATIONS)

Voltage

- 15: 0 - 50 mV DC (Input resistance 10 kΩ min.)
- 16: 0 - 60 mV DC (Input resistance 10 kΩ min.)
- 2: 0 - 100 mV DC (Input resistance 100 kΩ min.)
- 3: 0 - 1 V DC (Input resistance 1 MΩ min.)
- 4: 0 - 10 V DC (Input resistance 1 MΩ min.)
- 5: 0 - 5 V DC (Input resistance 1 MΩ min.)
- 6: 1 - 5 V DC (Input resistance 1 MΩ min.)
- 4W: -10 - +10 V DC (Input resistance 1 MΩ min.)
- 5W: -5 - +5 V DC (Input resistance 1 MΩ min.)
- 0: Specify voltage (See INPUT SPECIFICATIONS)

OUTPUT

- 5: Relay; SPDT or transfer contact

[2] POWER INPUT

AC Power

- G: 200 V AC
- H: 220 V AC
- J: 240 V AC

DC Power

- S: 12 V DC
- R: 24 V DC

GENERAL SPECIFICATIONS

Construction: Plug-in

Connection: M3.5 screw terminals

Housing material: Flame-resistant resin (black)

Isolation: Input to output to power

Setpoint adjustments: Multi-turn screwdriver adjustments (front); 0 - 100% independently

Monitor jacks: Output 0 - 10 V for 0 - 100 % setpoints

Hysteresis (deadband): 0.5 - 1.0 %

Front LEDs: Red lights turn on when the coils are energized.

Power ON timer: Relays de-energized for approx. 2 seconds after power is turned on.

INPUT SPECIFICATIONS

■ DC Current:

Shunt resistor attached to the input terminals (0.5 W)
Specify input resistance value for code Z.

■ DC Voltage: -30 - +30 V DC

Span: Min. 50 mV, Max. 30 V

Offset: Max. 1.5 times span

Input resistance

Span 50 - 100 mV : $\geq 10 \text{ k}\Omega$

Span 0.1 - 1 V : $\geq 100 \text{ k}\Omega$

Span $\geq 1 \text{ V}$: $\geq 1 \text{ M}\Omega$



OUTPUT SPECIFICATIONS

■ Relay Contact:

120 V AC @ 0.5 A ($\cos \phi = 1$)

240 V AC @ 0.5 A ($\cos \phi = 1$)

30 V DC @ 0.5 A (resistive load)

Maximum switching voltage: 380 V AC or 125 V DC

Maximum switching power: 120 VA or 30 W (≤ 0.5 A)

Minimum load: 5 V DC @ 10 mA

Mechanical life: 5×10^7 cycles

For maximum relay life with inductive loads, external protection is recommended.

EN 61010-1: 2001

Measurement Category II (alarm)

Installation Category II (power)

Pollution degree 2

Input or output to power: Reinforced insulation (300 V)

Input to output: Basic insulation (300 V)

(When 150 V AC max. load voltage or measurement category I, applicable as reinforced insulation)

Alarm Trip Operation Terminal No. in parentheses

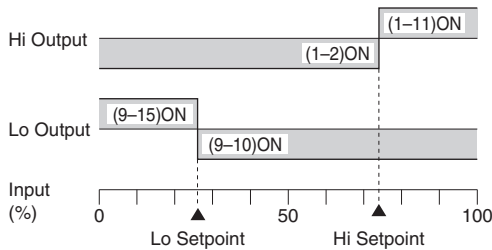

Trip Operation in Power Failure

: Terminals 1 – 2, 9 – 10 turn ON.

INSTALLATION

Power input

•AC: Operational voltage range: rating ± 10 %, 50/60 ± 2 Hz, approx. 2 VA

•DC: Operational voltage range: rating ± 10 %, ripple 10 %p-p max., approx. 2 W (80 mA at 24 V)

Operating temperature: -5 to +55°C (23 to 131°F)

Operating humidity: 30 to 90 %RH (non-condensing)

Mounting: Surface or DIN rail

Weight: 400 g (0.88 lbs)

PERFORMANCE in percentage of span

Setpoint monitor accuracy: ± 0.5 %

Temp. coefficient: ± 0.02 %/°C (± 0.01 %/°F)

Response time: ≤ 0.5 sec. (0 - 100 % at 90 % setpoint)

Line voltage effect: ± 0.1 % over voltage range

Insulation resistance: ≥ 100 M Ω with 500 V DC

Dielectric strength: 2300 V AC @1 minute (input to output to power to ground)

STANDARDS & APPROVALS

CE conformity:

EMC Directive (2004/108/EC)

EMI EN 61000-6-4: 2007

EMS EN 61000-6-2: 2005

Low Voltage Directive (2006/95/EC)



幸託有限公司
XIN TOP CORPORATION

TEL : (02)2598-1199

FAX : (02)2596-2331

E-mail : info@xintop.com

Website : www.xintop.com

EXTERNAL VIEW

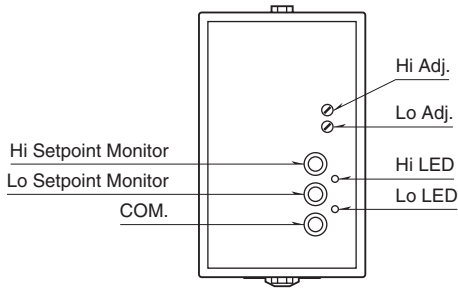

EXTERNAL DIMENSIONS & TERMINAL ASSIGNMENTS unit: mm (inch)

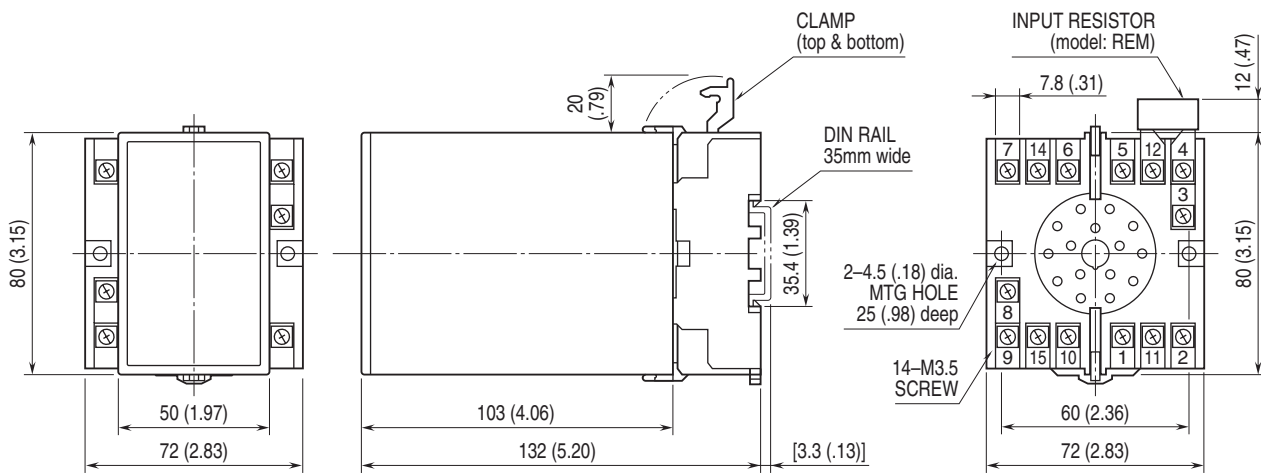

- When mounting, no extra space is needed between units.
- Input shunt resistor attached for current input.

SCHEMATIC CIRCUITRY & CONNECTION DIAGRAM

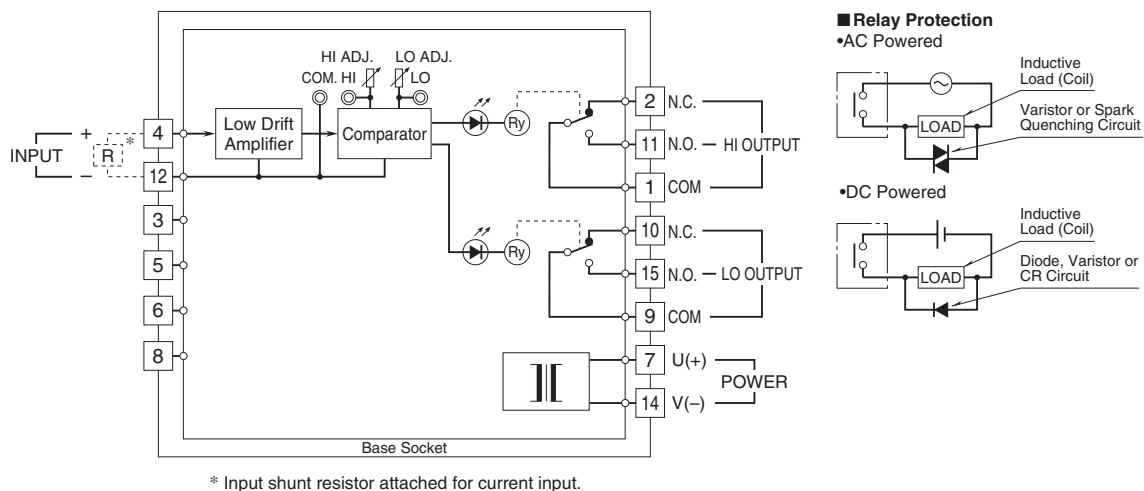

Specifications are subject to change without notice.



幸託有限公司
XIN TOP CORPORATION

TEL : (02)2598-1199
FAX : (02)2596-2331

E-mail : info@xintop.com
Website : www.xintop.com