

Plug-in Signal Conditioners K-UNIT

DC ALARM

Functions & Features

- Providing relay contact closures at preset DC input levels
- Dual (Hi/Lo) trip
- Multi-turn screwdriver setpoint adjustments
- Monitor jacks provided for setpoint adjustments
- Enclosed relays
- Relays can be powered 110 V DC
- Isolation up to 2000 V AC
- High-density mounting

Typical Applications

- Annunciator
- Various alarm applications

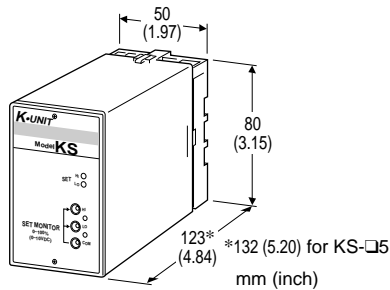

MODEL: KS-[1][2]-[3]

ORDERING INFORMATION

- Code number: KS-[1][2]-[3]
- Specify a code from below for each [1] through [3]. (e.g. KS-62-B)
- Special input range (For codes Z & 0)

[1] INPUT

Current

- A: 4 - 20 mA DC (Input resistance 250 Ω)
- A1: 4 - 20 mA DC (Input resistance 50 Ω)
- B: 2 - 10 mA DC (Input resistance 500 Ω)
- C: 1 - 5 mA DC (Input resistance 1000 Ω)
- D: 0 - 20 mA DC (Input resistance 50 Ω)
- E: 0 - 16 mA DC (Input resistance 62.5 Ω)
- F: 0 - 10 mA DC (Input resistance 100 Ω)
- G: 0 - 1 mA DC (Input resistance 1000 Ω)
- H: 10 - 50 mA DC (Input resistance 100 Ω)
- J: 0 - 10 μA DC (Input resistance 1000 Ω)
- K: 0 - 100 μA DC (Input resistance 1000 Ω)
- GW: -1 - +1 mA DC (Input resistance 1000 Ω)
- FW: -10 - +10 mA DC (Input resistance 100 Ω)
- Z: Specify current (See INPUT SPECIFICATIONS)

Voltage

- 1: 0 - 10 mV DC (Input resistance 10 kΩ min.)
- 15: 0 - 50 mV DC (Input resistance 10 kΩ min.)
- 16: 0 - 60 mV DC (Input resistance 10 kΩ min.)
- 2: 0 - 100 mV DC (Input resistance 100 kΩ min.)
- 3: 0 - 1 V DC (Input resistance 1 MΩ min.)
- 4: 0 - 10 V DC (Input resistance 1 MΩ min.)
- 5: 0 - 5 V DC (Input resistance 1 MΩ min.)
- 6: 1 - 5 V DC (Input resistance 1 MΩ min.)
- 4W: -10 - +10 V DC (Input resistance 1 MΩ min.)
- 5W: -5 - +5 V DC (Input resistance 1 MΩ min.)
- 0: Specify voltage (See INPUT SPECIFICATIONS)

[2] OUTPUT

- 1: Open collector
- 2: Relay; N.O. or make contact
- 3: Relay; N.C. or break contact
- 4: SSR
- 5: Relay; SPDT or transfer contact

[3] POWER INPUT

AC Power

- B: 100 V AC
- C: 110 V AC
- D: 115 V AC
- F: 120 V AC
- G: 200 V AC
- H: 220 V AC
- J: 240 V AC

DC Power

- S: 12 V DC
- R: 24 V DC

GENERAL SPECIFICATIONS

- Construction:** Plug-in
- Connection:** M3.5 screw terminals
- Housing material:** Flame-resistant resin (black)
- Isolation:** Input to output to power
- Setpoint adjustments:** Multi-turn screwdriver adjustments (front); 0 - 100% independently
- Monitor jacks:** Output 0 - 10 V for 0 - 100 % setpoints
- Hysteresis (deadband):** 0.5 - 1.0 %
- Front LEDs:** Red lights turn on in tripped conditions
- Power ON timer:** The output devices will not be driven for approx. 2 sec. after the power is turned on.

INPUT SPECIFICATIONS

- **DC Current:**
Shunt resistor attached to the input terminals (0.5 W)
Specify input resistance value for code Z.



■ **DC Voltage:** -300 - +300 V DC

Minimum span: 10 mV

Offset: Max. 1.5 times span

Input resistance

Span 10 - 100 mV : $\geq 10 \text{ k}\Omega$

Span 0.1 - 1 V : $\geq 100 \text{ k}\Omega$

Span $\geq 1 \text{ V}$: $\geq 1 \text{ M}\Omega$

OUTPUT SPECIFICATIONS

■ **Open Collector:** 50 V DC @100 mA

Voltage drop: $\leq 2 \text{ V}$

■ **Relay Contact:** 120 V AC @1 A ($\cos \phi = 1$)

240 V AC @0.5 A ($\cos \phi = 1$)

30 V DC @1 A (resistive load)

Maximum switching voltage: 380 V AC or 125 V DC

Maximum switching power: 120 VA or 30 W

Minimum load: 5 V DC @10 mA

Mechanical life: 5×10^7 cycles

For maximum relay life with inductive loads, external protection is recommended.

■ **SSR:** 60 - 280 V AC @0.1 - 1 A

Leakage current at OFF: Approx. 10 mA (240 V AC)

Alarm Trip Operation Terminal No. in parentheses

• **Output Code : 1, 2, 4**

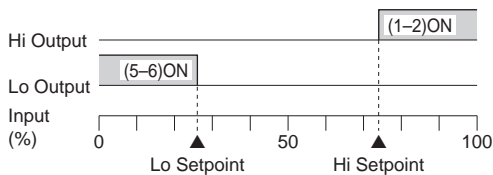

• **Output Code : 3**

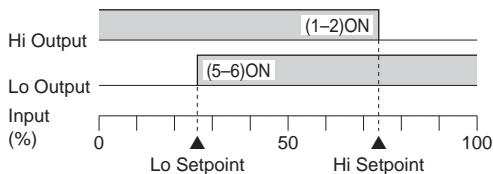

• **Output Code : 5**

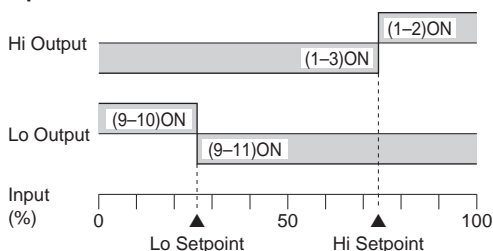

Trip Operation in Power Failure

• **Output Code : 1, 2, 4:** both relays turn OFF

• **Output Code : 3:** both relays turn ON

• **Output Code : 5:** Terminals 1 - 3, 9 - 11 turn ON

INSTALLATION

Power input

• **AC:** Operational voltage range: rating $\pm 10 \%$, 50/60 ± 2 Hz, approx. 2 VA

• **DC:** Operational voltage range: rating $\pm 10 \%$, ripple 10 %p-p max., approx. 2 W (80 mA at 24 V)

Operating temperature: -5 to +55°C (23 to 131°F)

Operating humidity: 30 to 90 %RH (non-condensing)

Mounting: Surface or DIN rail

Weight: 400 g (0.88 lb)

PERFORMANCE in percentage of span

Setpoint monitor accuracy: $\pm 0.5 \%$

Temp. coefficient: $\pm 0.02 \%/^{\circ}\text{C}$ ($\pm 0.01 \%/^{\circ}\text{F}$)

Response time: ≤ 0.5 sec. (0 - 100 % at 90 % setpoint)

Line voltage effect: $\pm 0.1 \%$ over voltage range

Insulation resistance: $\geq 100 \text{ M}\Omega$ with 500 V DC

Dielectric strength: 2000 V AC @1 minute (input to output to power to ground)



EXTERNAL VIEW

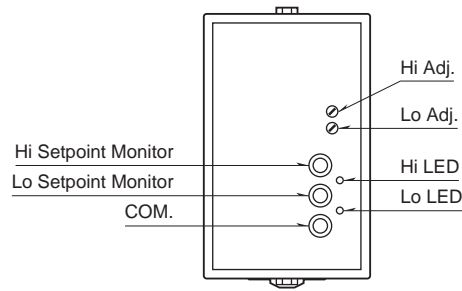

DIMENSIONS unit: mm (inch)

■OUTPUT CODE: 1, 2, 3, 4

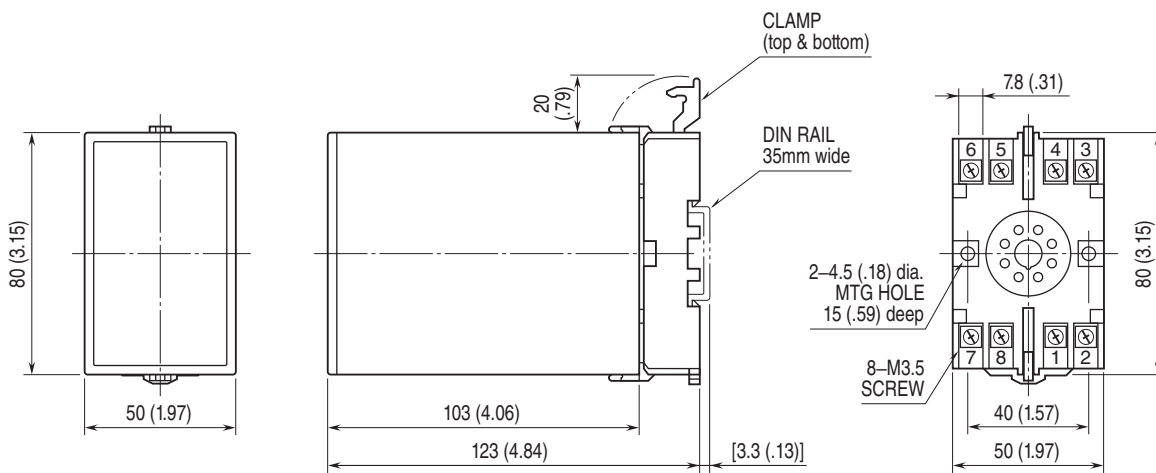

• When mounting, no extra space is needed between units.

■OUTPUT CODE: 5

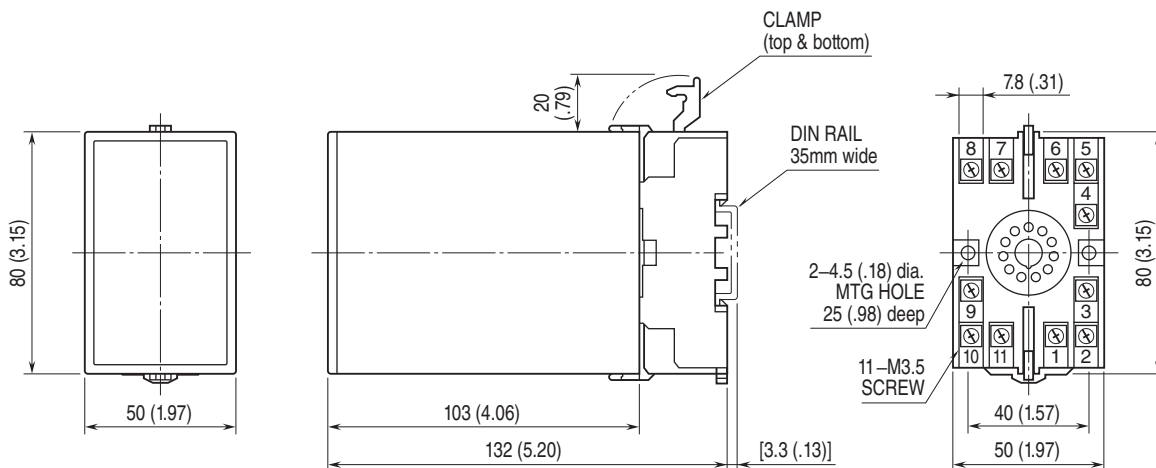

• When mounting, no extra space is needed between units.

TERMINAL ASSIGNMENTS unit: mm (inch)

- Output Code 1, 2, 3 & 4

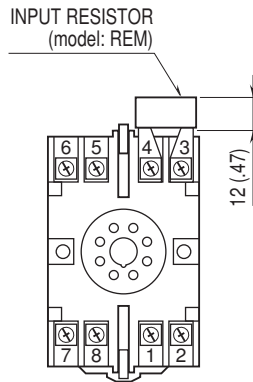

Input shunt resistor attached for current input.

- Output Code 5

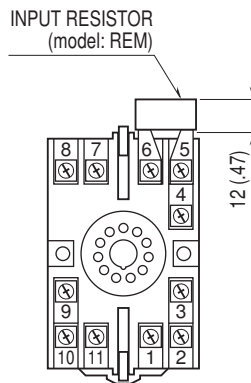

Input shunt resistor attached for current input.

SCHEMATIC CIRCUITRY & CONNECTION DIAGRAM

- Output Code 1, 2, 3 & 4

Open Collector

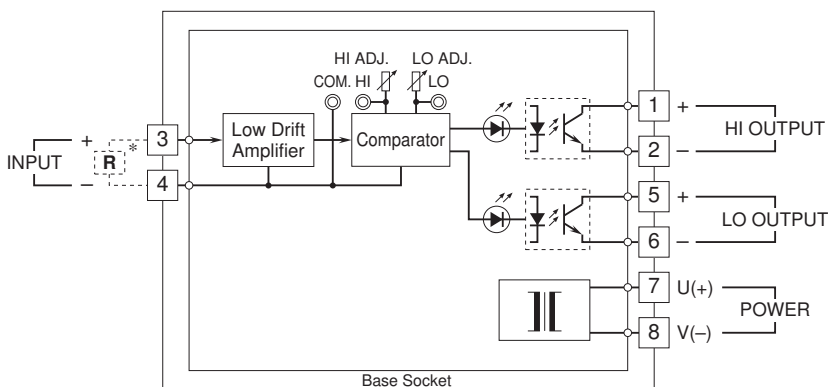

*Input shunt resistor attached for current input.

N.O. (make) Relay

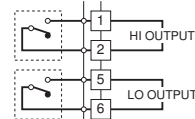

N.C. (break) Relay

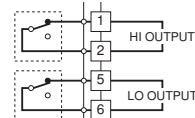

SSR

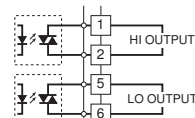

• Output Code 5

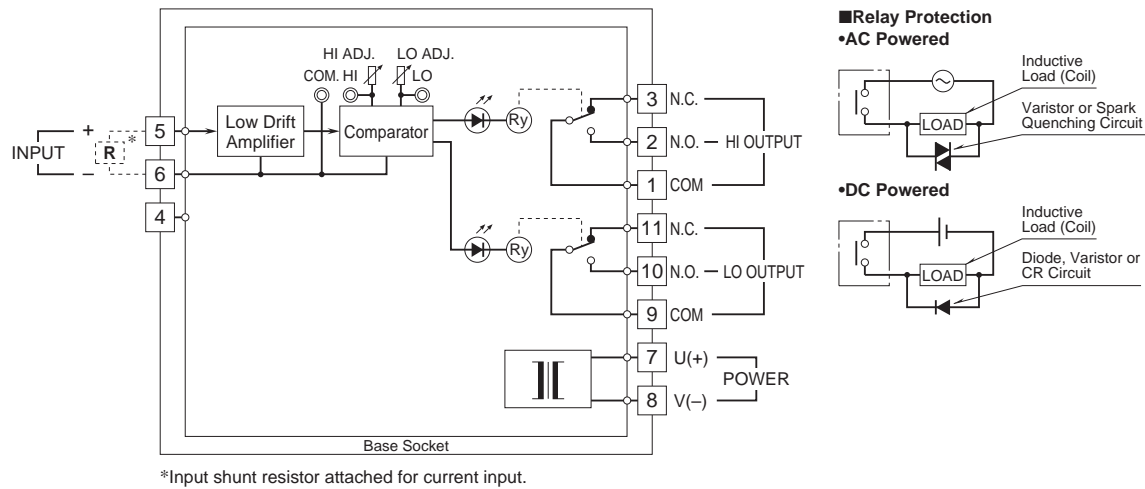

Specifications are subject to change without notice.