

Plug-in Signal Conditioners K-UNIT

LIMITER

(non-isolated)

Functions & Features

- Preventing DC output signals from going above or below preset values
- High and low limits independently adjustable over entire range
- Monitor jacks provided for setpoint adjustments
- High-density mounting

Typical Applications

- Securing the minimum fuel flow in a combustion control loop

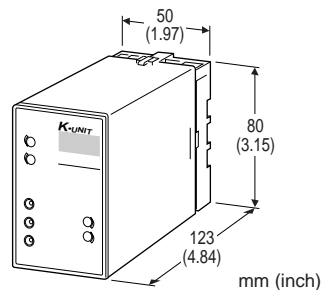

MODEL: KL-[1][2]-[3][4]

ORDERING INFORMATION

- Code number: KL-[1][2]-[3][4]
- Specify a code from below for each [1] through [4]. (e.g. KL-6A-B/Q)
- Special input and output ranges (For codes Z & Q)
- Specify the specification for option code /Q (e.g. /C01/S01)

[1] INPUT

Current

- A: 4 - 20 mA DC (Input resistance 250 Ω)
- A1: 4 - 20 mA DC (Input resistance 50 Ω)
- B: 2 - 10 mA DC (Input resistance 500 Ω)
- C: 1 - 5 mA DC (Input resistance 1000 Ω)
- D: 0 - 20 mA DC (Input resistance 50 Ω)
- E: 0 - 16 mA DC (Input resistance 62.5 Ω)
- F: 0 - 10 mA DC (Input resistance 100 Ω)
- G: 0 - 1 mA DC (Input resistance 1000 Ω)
- H: 10 - 50 mA DC (Input resistance 100 Ω)
- J: 0 - 10 μA DC (Input resistance 1000 Ω)
- K: 0 - 100 μA DC (Input resistance 1000 Ω)
- GW: -1 - +1 mA DC (Input resistance 1000 Ω)

FW: -10 - +10 mA DC (Input resistance 100 Ω)

Z: Specify current (See INPUT SPECIFICATIONS)

Voltage

- 1: 0 - 10 mV DC (Input resistance 10 kΩ min.)
- 15: 0 - 50 mV DC (Input resistance 10 kΩ min.)
- 16: 0 - 60 mV DC (Input resistance 10 kΩ min.)
- 2: 0 - 100 mV DC (Input resistance 100 kΩ min.)
- 3: 0 - 1 V DC (Input resistance 1 MΩ min.)
- 4: 0 - 10 V DC (Input resistance 1 MΩ min.)
- 5: 0 - 5 V DC (Input resistance 1 MΩ min.)
- 6: 1 - 5 V DC (Input resistance 1 MΩ min.)
- 4W: -10 - +10 V DC (Input resistance 1 MΩ min.)
- 5W: -5 - +5 V DC (Input resistance 1 MΩ min.)
- 0: Specify voltage (See INPUT SPECIFICATIONS)

[2] OUTPUT

Current

- A: 4 - 20 mA DC (Load resistance 750 Ω max.)
- B: 2 - 10 mA DC (Load resistance 1500 Ω max.)
- C: 1 - 5 mA DC (Load resistance 3000 Ω max.)
- D: 0 - 20 mA DC (Load resistance 750 Ω max.)
- E: 0 - 16 mA DC (Load resistance 900 Ω max.)
- F: 0 - 10 mA DC (Load resistance 1500 Ω max.)
- G: 0 - 1 mA DC (Load resistance 15 kΩ max.)
- Z: Specify current (See OUTPUT SPECIFICATIONS)

Voltage

- 1: 0 - 10 mV DC (Load resistance 10 kΩ min.)
- 2: 0 - 100 mV DC (Load resistance 100 kΩ min.)
- 3: 0 - 1 V DC (Load resistance 100 Ω min.)
- 4: 0 - 10 V DC (Load resistance 1000 Ω min.)
- 5: 0 - 5 V DC (Load resistance 500 Ω min.)
- 6: 1 - 5 V DC (Load resistance 500 Ω min.)
- 4W: -10 - +10 V DC (Load resistance 2000 Ω min.)
- 5W: -5 - +5 V DC (Load resistance 1000 Ω min.)
- 0: Specify voltage (See OUTPUT SPECIFICATIONS)

[3] POWER INPUT

AC Power

- B: 100 V AC
- C: 110 V AC
- D: 115 V AC
- F: 120 V AC
- G: 200 V AC
- H: 220 V AC
- J: 240 V AC

DC Power

- S: 12 V DC
- R: 24 V DC



[4] OPTIONS**Other Options**

blank: none

/Q: Option other than the above (specify the specification)

SPECIFICATIONS OF OPTION: Q (multiple selections)**COATING (For the detail, refer to M-System's web site.)**

/C01: Silicone coating

/C02: Polyurethane coating

/C03: Rubber coating

TERMINAL SCREW MATERIAL

/S01: Stainless steel

GENERAL SPECIFICATIONS**Construction:** Plug-in**Connection:** M3.5 screw terminals**Screw terminal:** Chromated steel (standard) or stainless steel**Housing material:** Flame-resistant resin (black)**Isolation:** Input or output to power**Overrange output:** Approx. -5 to +105 % at 1 - 5 V**Zero adjustment:** -5 to +5 % (front)**Span adjustment:** 95 to 105 % (front)**Limit adjustments:** Multi-turn screwdriver adjustments (front); 0 - 100 %; factory set to 0 % for low, 100 % for high**Monitor output:** 0 - 10 V for 0 - 100 % limit**Monitor jacks:** 2 mm (.08") dia.**INPUT SPECIFICATIONS****■ DC Current:**

Shunt resistor attached to the input terminals (0.5 W)

Specify input resistance value for code Z.

■ DC Voltage: -300 - +300 V DC**Minimum span:** 3 mV**Offset:** Max. 1.5 times span**Input resistance**Span 3 - 10 mV : $\geq 10 \text{ k}\Omega$ Span 10 - 100 mV : $\geq 10 \text{ k}\Omega$ Span 0.1 - 1 V : $\geq 100 \text{ k}\Omega$ Span $\geq 1 \text{ V}$: $\geq 1 \text{ M}\Omega$ **OUTPUT SPECIFICATIONS****■ DC Current:** 0 - 20 mA DC**Minimum span:** 1 mA**Offset:** Max. 1.5 times span**Load resistance:** Output drive 15 V max.**■ DC Voltage:** -10 - +12 V DC**Minimum span:** 5 mV**Offset:** Max. 1.5 times span**Load resistance:** Output drive 10 mA max.; 5 mA fornegative voltage output; at $\geq 0.5 \text{ V}$ **INSTALLATION****Power input****•AC:** Operational voltage range: rating $\pm 10 \%$, 50/60 ± 2 Hz, approx. 2 VA**•DC:** Operational voltage range: rating $\pm 10 \%$, ripple 10 %p-p max., approx. 2 W (90 mA at 24 V)**Operating temperature:** -5 to +55°C (23 to 131°F)**Operating humidity:** 30 to 90 %RH (non-condensing)**Mounting:** Surface or DIN rail**Weight:** 300 g (0.66 lb)**PERFORMANCE in percentage of span****Accuracy:** $\pm 0.1 \%$ **Limit monitor accuracy:** $\pm 0.25 \%$ **Temp. coefficient:** $\pm 0.02 \%/^{\circ}\text{C}$ ($\pm 0.01 \%/^{\circ}\text{F}$)**Response time:** $\leq 0.5 \text{ sec.}$ (0 - 90 %)**Line voltage effect:** $\pm 0.1 \%$ over voltage range**Insulation resistance:** $\geq 100 \text{ M}\Omega$ with 500 V DC**Dielectric strength:** 2000 V AC @1 minute (input or output to power to ground)

EXTERNAL VIEW

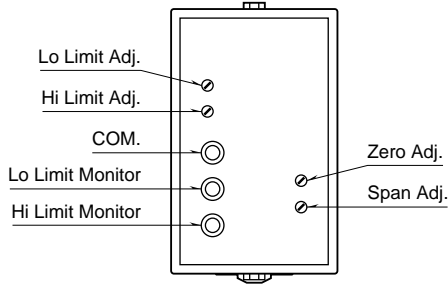

DIMENSIONS unit: mm (inch)

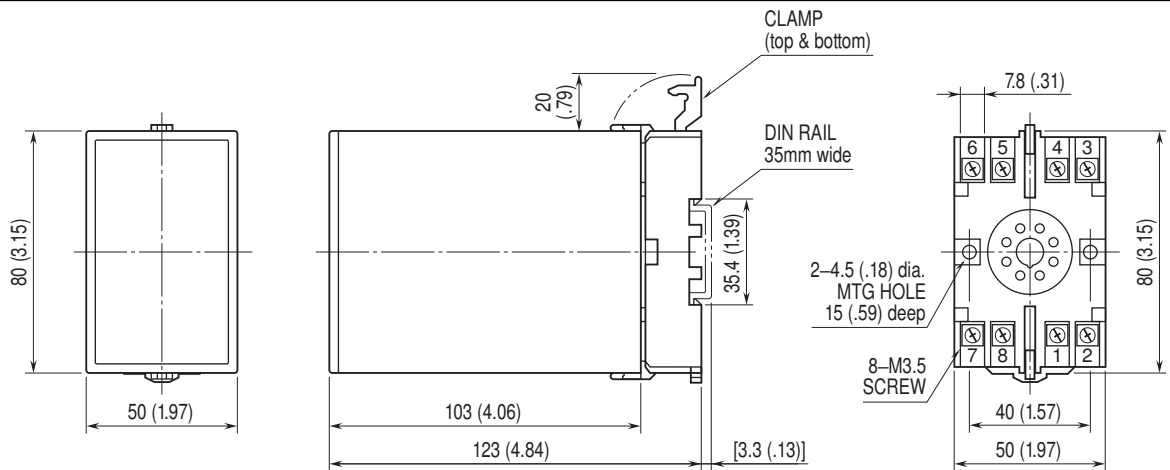

• When mounting, no extra space is needed between units.

TERMINAL ASSIGNMENTS unit: mm (inch)

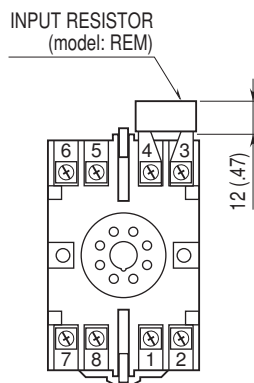

Input shunt resistor attached for current input.

SCHEMATIC CIRCUITRY & CONNECTION DIAGRAM

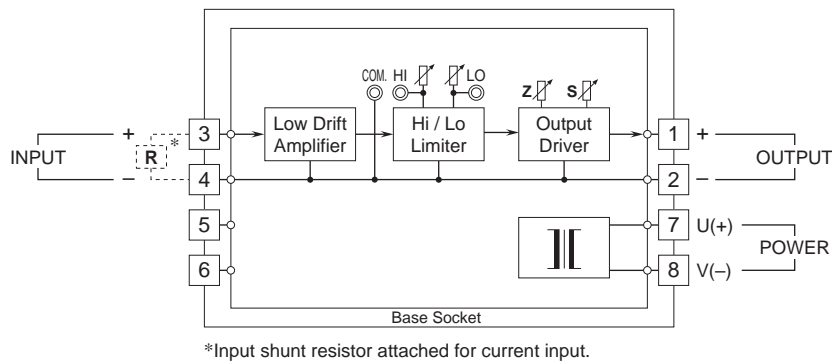

Specifications are subject to change without notice.

