

Plug-in Signal Conditioners K-UNIT

RAMP BUFFER

(non-isolated)

Functions & Features

- Limiting the rate of change of the output once the rate of the input exceeds the preset value
- Rate-of-change adjustable up to 40 seconds

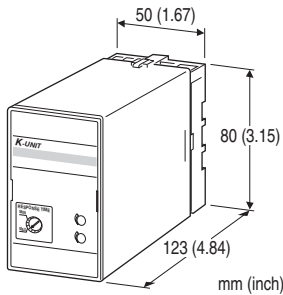

MODEL: KCR-[1][2]-[3][4]

ORDERING INFORMATION

- Code number: KCR-[1][2]-[3][4]
- Specify a code from below for each [1] through [4]. (e.g. KCR-6A-B/Q)
- Special input and output ranges (For codes Z & O)
- Specify the specification for option code /Q (e.g. /C01/S01)

[1] INPUT

Current

- A: 4 - 20 mA DC (Input resistance 250 Ω)
- A1: 4 - 20 mA DC (Input resistance 50 Ω)
- B: 2 - 10 mA DC (Input resistance 500 Ω)
- C: 1 - 5 mA DC (Input resistance 1000 Ω)
- D: 0 - 20 mA DC (Input resistance 50 Ω)
- E: 0 - 16 mA DC (Input resistance 62.5 Ω)
- F: 0 - 10 mA DC (Input resistance 100 Ω)
- G: 0 - 1 mA DC (Input resistance 1000 Ω)
- H: 10 - 50 mA DC (Input resistance 100 Ω)
- J: 0 - 10 μ A DC (Input resistance 1000 Ω)
- K: 0 - 100 μ A DC (Input resistance 1000 Ω)
- GW: -1 - +1 mA DC (Input resistance 1000 Ω)
- FW: -10 - +10 mA DC (Input resistance 100 Ω)
- Z: Specify current (See INPUT SPECIFICATIONS)

Voltage

- 1: 0 - 10 mV DC (Input resistance 10 k Ω min.)
- 15: 0 - 50 mV DC (Input resistance 10 k Ω min.)
- 16: 0 - 60 mV DC (Input resistance 10 k Ω min.)
- 2: 0 - 100 mV DC (Input resistance 100 k Ω min.)

- 3: 0 - 1 V DC (Input resistance 1 M Ω min.)
- 4: 0 - 10 V DC (Input resistance 1 M Ω min.)
- 5: 0 - 5 V DC (Input resistance 1 M Ω min.)
- 6: 1 - 5 V DC (Input resistance 1 M Ω min.)
- 4W: -10 - +10 V DC (Input resistance 1 M Ω min.)
- 5W: -5 - +5 V DC (Input resistance 1 M Ω min.)
- 0: Specify voltage (See INPUT SPECIFICATIONS)

[2] OUTPUT

Current

- A: 4 - 20 mA DC (Load resistance 750 Ω max.)
- B: 2 - 10 mA DC (Load resistance 1500 Ω max.)
- C: 1 - 5 mA DC (Load resistance 3000 Ω max.)
- D: 0 - 20 mA DC (Load resistance 750 Ω max.)
- E: 0 - 16 mA DC (Load resistance 900 Ω max.)
- F: 0 - 10 mA DC (Load resistance 1500 Ω max.)
- G: 0 - 1 mA DC (Load resistance 15 k Ω max.)
- Z: Specify current (See OUTPUT SPECIFICATIONS)

Voltage

- 1: 0 - 10 mV DC (Load resistance 10 k Ω min.)
- 2: 0 - 100 mV DC (Load resistance 100 k Ω min.)
- 3: 0 - 1 V DC (Load resistance 100 Ω min.)
- 4: 0 - 10 V DC (Load resistance 1000 Ω min.)
- 5: 0 - 5 V DC (Load resistance 500 Ω min.)
- 6: 1 - 5 V DC (Load resistance 500 Ω min.)
- 4W: -10 - +10 V DC (Load resistance 2000 Ω min.)
- 5W: -5 - +5 V DC (Load resistance 1000 Ω min.)
- 0: Specify voltage (See OUTPUT SPECIFICATIONS)

[3] POWER INPUT

AC Power

- B: 100 V AC
- C: 110 V AC
- D: 115 V AC
- F: 120 V AC
- G: 200 V AC
- H: 220 V AC
- J: 240 V AC

DC Power

- S: 12 V DC
- R: 24 V DC

[4] OPTIONS

Other Options

- blank: none
- /Q: Option other than the above (specify the specification)



SPECIFICATIONS OF OPTION: Q (multiple selections)

COATING (For the detail, refer to M-System's web site.)

/C01: Silicone coating

/C02: Polyurethane coating

/C03: Rubber coating

TERMINAL SCREW MATERIAL

/S01: Stainless steel

50/60 \pm 2 Hz, approx. 2 VA

•DC: Operational voltage range: rating \pm 10 %, ripple 10 %p-p max., approx. 2 W (90 mA at 24 V)

Operating temperature: -5 to +55°C (23 to 131°F)

Operating humidity: 30 to 90 %RH (non-condensing)

Mounting: Surface or DIN rail

Weight: 400 g (0.88 lb)

GENERAL SPECIFICATIONS

Construction: Plug-in

Connection: M3.5 screw terminals

Screw terminal: Chromated steel (standard) or stainless steel

Housing material: Flame-resistant resin (black)

Isolation: Input or output to power

Overrange output: Approx. -10 to +120 % at 1 - 5 V

Rate-of-change adjustment: 270°-turn screwdriver adjustment (front)

Rate-of-change adjustment range: Approx. 0.5 to 40 sec. (0 - 100 %)

Zero adjustment: -5 to +5 % (front)

Span adjustment: 95 to 105 % (front)

PERFORMANCE in percentage of span

Accuracy: \pm 0.2 %

Temp. coefficient: \pm 0.02 %/°C (\pm 0.01 %/°F)

Line voltage effect: \pm 0.1 % over voltage range

Insulation resistance: \geq 100 M Ω with 500 V DC

Dielectric strength: 2000 V AC @1 minute (input or output to power to ground)

INPUT SPECIFICATIONS

■ DC Current:

Shunt resistor attached to the input terminals (0.5 W)

Specify input resistance value for code Z.

■ DC Voltage: -300 - +300 V DC

Minimum span: 3 mV

Offset: Max. 1.5 times span

Input resistance

Span 3 - 10 mV : \geq 10 k Ω

Span 10 - 100 mV : \geq 10 k Ω

Span 0.1 - 1 V : \geq 100 k Ω

Span \geq 1 V : \geq 1 M Ω

OUTPUT SPECIFICATIONS

■ DC Current: 0 - 20 mA DC

Minimum span: 1 mA

Offset: Max. 1.5 times span

Load resistance: Output drive 15 V max.

■ DC Voltage: -10 - +12 V DC

Minimum span: 5 mV

Offset: Max. 1.5 times span

Load resistance: Output drive 10 mA max.; 5 mA for negative voltage output; at \geq 0.5 V

INSTALLATION

Power input

• AC: Operational voltage range: rating \pm 10 %,



EXTERNAL VIEW

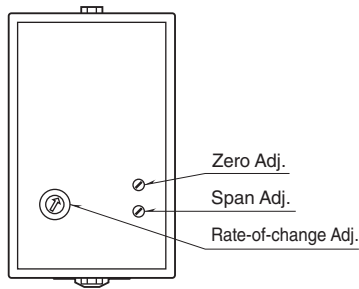

DIMENSIONS unit: mm (inch)

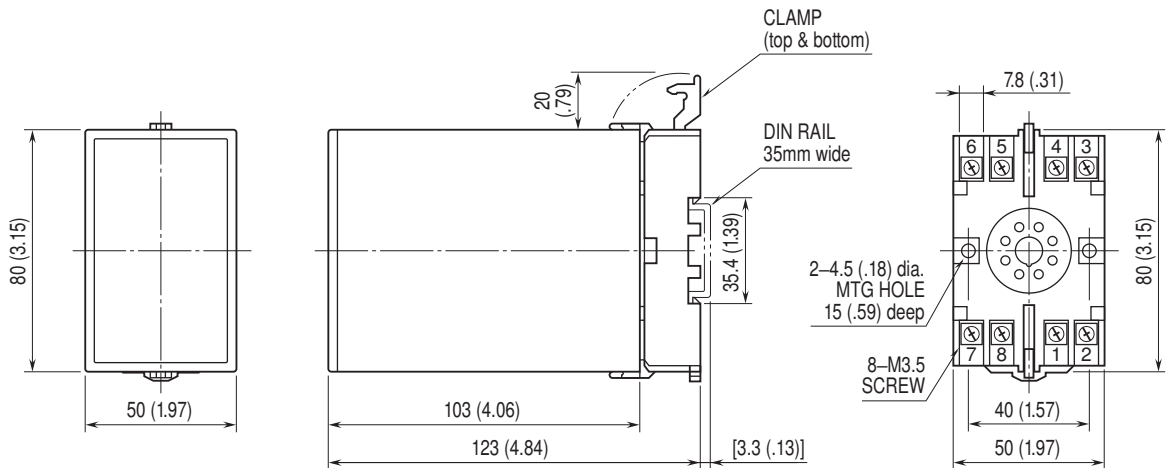

• When mounting, no extra space is needed between units.

TERMINAL ASSIGNMENTS unit: mm (inch)

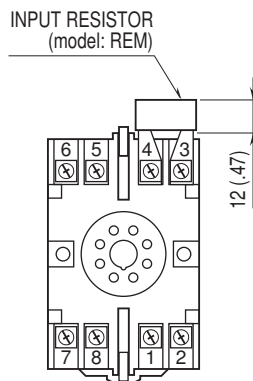

Input shunt resistor attached for current input.

SCHEMATIC CIRCUITRY & CONNECTION DIAGRAM

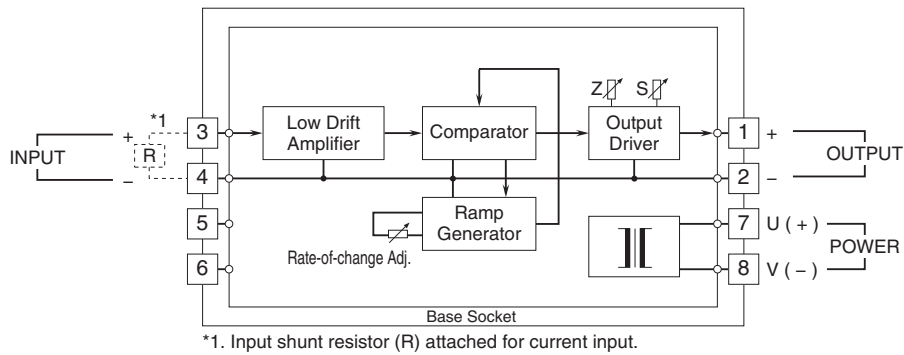

Specifications are subject to change without notice.

