

Plug-in Signal Conditioners M-UNIT

PULSE SCALER

(field-programmable; built-in excitation)

Functions & Features

- Converts pulse rate into convenient engineering unit for display on a totalizing counter or meter
- Various outputs
- Sensor excitation
- Scaling factor is user-programmable by simply setting input and output frequencies via handheld programmer PU-2x
- Isolation up to 2000 V AC

Typical Applications

- Positive displacement flowmeters or turbine flowmeters
- Converts dry contact pulse signals from a rotating machine into an engineering unit

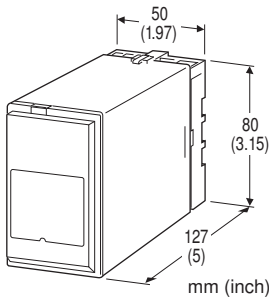

MODEL: JPR2-[1][2][3][4]-[5][6]

ORDERING INFORMATION

- Code number: JPR2-[1][2][3][4]-[5][6]
- Specify a code from below for each [1] through [6]. (e.g. JPR2-4P1N-K/Q)
- Use Ordering Information Sheet (No. ESU-1580). Default setting (table below) will be used if not otherwise specified.
- Specify the specification for option code /Q (e.g. /C01/S01)

Factory default setting

PARAMETER	DEFAULT
Input	Open collector
Input pulse amplitude	---
Noise filter	None
Detecting level *	1V (5V excitation) 2V (12V/24V excitation)
Input pulse set count	1
Output pulse set count	1
Sampling time	0.1 second
Max. output frequency	10 Hz
One shot output	50 milliseconds

* Internal voltage

INPUT - Field-selectable

- Open collector
- Mechanical contact
- Voltage pulse
- Two-wire current pulse
- RS-422 line driver pulse

[1] EXCITATION

- 1: 5 V DC @ 120 mA
- 4: 12 V DC @ 60 mA
- 7: 24 V DC @ 25 mA

[2] OUTPUT

- A: Open collector (max. 100 kHz)
- M: 5 V pulse (max. 100 kHz)
- N: 12 V pulse (max. 100 kHz)
- P: 24 V pulse (max. 100 kHz)
- J: RS-422 line driver pulse (max. 100 kHz)
- R: Noncontact AC/DC switch (max. 20 Hz)

[3] OUTPUT PULSE WIDTH

- 1: Equal to the input
- 3: One-shot output (std. pulse width 50 ms)
(Specify when optional pulse width is required.)

[4] OUTPUT LOGIC

- N: The same as the input
- R: Inverted

[5] POWER INPUT

- AC Power**
- K: 85 - 132 V AC
- DC Power**
- S: 12 V DC
- R: 24 V DC
- V: 48 V DC
- P: 110 V DC

[6] OPTIONS

- blank: none
- /Q: With options (specify the specification)

SPECIFICATIONS OF OPTION: Q (multiple selections)

COATING (For the detail, refer to M-System's web site.)

- /C01: Silicone coating
- /C02: Polyurethane coating
- /C03: Rubber coating

TERMINAL SCREW MATERIAL

- /S01: Stainless steel



CAUTION

- 1) The JPR2 is not designed to output uniform pulses even when the input wave is uniform. It is not applicable to certain types of application.
- 2) The JPR2 converts the pulse counts, not frequency. For the frequency conversion purpose, model JFR2 is recommended.

RELATED PRODUCTS

- JX configurator connection kit (model: JXCON)
- Programming Unit (model: PU-2x)

GENERAL SPECIFICATIONS

Construction: Plug-in
Connection: M3.5 screw terminals
Screw terminal: Chromated steel (standard) or stainless steel
Housing material: Flame-resistant resin (black)
Isolation: Input or sensor exc. to output to power
Input monitor LED: Red LED blinks according to the input.
Excitation adjustment: 5 - 24 V DC
Software programming: Programming Unit (model: PU-2x)
 input and output pulse set count (frequency), sampling time, input pulse edge, max. frequency limit, etc. (Refer to the users manual of JXCON for the adjustments configurable with JXCON.)
Sampling time: 0.01 - 100 sec.
Buffer counter capacity: 4 294 967 295 counts
Input pulse sensing: DC coupled

INPUT SPECIFICATIONS

Excitation: Shortcircuit protection; approx. 440 mA (max.) at shortcircuit
Max. frequency: 100 kHz
 (10 Hz for mechanical contact input)
Minimum pulse width time requirement: 5 μ sec.; 50 msec.
 for mechanical contact (for both ON and OFF)
■ Open Collector & Mechanical Contact Input requirements (Excitation: Sensing)
 5 V: Approx. 4 V / 1.0 mA
 12 V: Approx. 9 V / 2.3 mA
 24 V: Approx. 16 V / 4.7 mA
Resistance at ON : \leq 200 Ω
Resistance at OFF : \geq 200 k Ω
Detecting level: 1 V with 5 V excitation
 2 V with 12 V/24 V excitation.
 (Detecting voltage in the internal circuit)
 For open collector or mechanical contact input, be sure to re-adjust the voltage back to 1 V (excitation 5 V) or 2 V (excitation 12 V/24 V) if it has been changed for other input types.

Detecting pulse edge: OFF (input monitor LED ON) to ON (input monitor LED OFF) or ON to OFF

■ Voltage Pulse

Waveform: Square or sine
Input impedance: \geq 10 k Ω
Pulse amplitude: 0.1 - 100 Vp-p (square)
 1 - 100 Vp-p (sine or similar)
Max. voltage between input terminals: 50 V
Detecting level: 0 - 5 V (Detecting voltage in the internal circuit.)

Detecting pulse state: A pulse rise detected when the input voltage goes above the detecting level (input monitor LED ON); a pulse sink detected when it goes below the level (input monitor LED OFF).

■ Two-wire Current Pulse

Input resistance: Receiving resistor 100 Ω
Input range: 0 - 25 mA
Minimum pulse amplitude: 10 mA
Detecting level: 0 - 5 V
 (Detecting voltage in the internal circuit.)

Detecting pulse state: The input resistor (100 Ω) converts the current signal (0 - 25 mA) into 0 - 2.5 V. A pulse rise detected when the voltage goes above the detecting level (input monitor LED ON); a pulse sink detected when it goes below the level (input monitor LED OFF).

■ RS-422 Line Driver Pulse

Receiver: Conforms to RS-422

Voltage pulse waveform

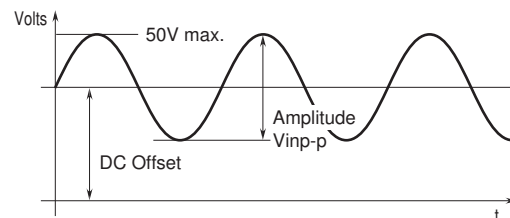

OUTPUT SPECIFICATIONS

Output pulse: No. of input pulse \times scaling factor (scaling factor = output pulse set count / input pulse set count)
Scalable range: 1/1 000 000 to 1 000 000
■ Open Collector: 50 V DC @ 50 mA (resistive load)
Saturation voltage: 0.6 V DC
Maximum frequency: 100 kHz
■ Voltage Pulse
H level: Rating (5, 12 or 24 V) \pm 10 %
L level: \leq 0.5 V
Load resistance: \geq 1 k Ω (5V), \geq 2.4 k Ω (12 V), \geq 4.8 k Ω (24 V)
Maximum frequency: 100 kHz
■ Noncontact AC/DC Switch: 120 V AC or 120 V DC @200



mA (resistive load)

ON resistance: 3 Ω

Maximum frequency: 20 Hz

Rise time: 5 msec.

Sink time: 3 msec.

■ **RS-422 Line Driver Pulse**

Transmitter: Conforms to RS-422

Maximum frequency: 100 kHz

OUTPUT PULSE WIDTH

• **Equal to the Input:** Duty ratio approx. 50 %; Internal digital computation calculates the pulse width.

• **One-shot Output:** Preset pulse width ±20 %

Optional pulse width: 30 μsec. – 300 msec.

INSTALLATION

Power input

• **AC:** Operational voltage range 85 – 132 V, 47 – 66 Hz, approx. 6 VA

• **DC:** Operational voltage range: Rating ±10 %, or 85 – 150 V for 110 V rating; ripple 10 %p-p max.; Approx. 3.3 W (140 mA at 24 V)

Operating temperature: -5 to +60°C (23 to 140°F)

Operating humidity: 30 to 90 %RH (non-condensing)

Mounting: Surface or DIN rail

Weight: 400 g (0.88 lb)

PERFORMANCE

Response time: Sampling time + 50 msec.

The response time equals the interval between the first input pulse and the first output pulse.

Insulation resistance: ≥ 100 MΩ with 500 V DC

Dielectric strength: 2000 V AC @ 1 minute (input or sensor excitation to output to power to ground)

EXTERNAL VIEW

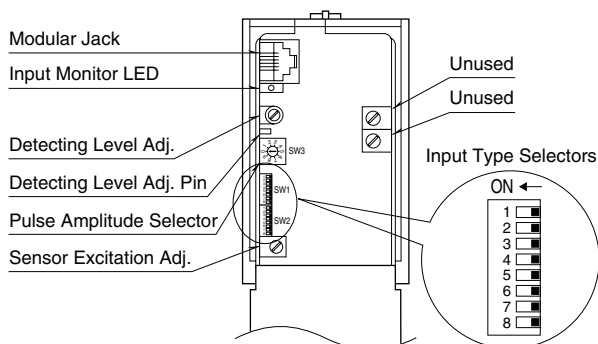

Refer to the instruction manual for detailed procedures.



OUTPUT LOGIC

OUTPUT WAVEFORM		INPUT WAVEFORM	Voltage Pulse 2-wire Current Pulse RS-422 Line Driver Pulse	Open Collector or Noncontact AC/DC Switch
			H L	OFF ON
Voltage Pulse or RS-422 Line Driver Pulse	Non Inverted	No pulse width conversion	H L	H L
		One-shot, detecting input pulse rise	H L	H L
		One-shot, detecting input pulse drop	H L	H L
	Inverted	No pulse width conversion	H L	H L
		One-shot, detecting input pulse rise	H L	H L
		One-shot, detecting input pulse drop	H L	H L
Open collector or Noncontact AC/DC Switch	Non Inverted	No pulse width conversion	OFF ON	OFF ON
		One-shot, detecting input pulse rise	OFF ON	OFF ON
		One-shot, detecting input pulse drop	OFF ON	OFF ON
	Inverted	No pulse width conversion	OFF ON	OFF ON
		One-shot, detecting input pulse rise	OFF ON	OFF ON
		One-shot, detecting input pulse drop	OFF ON	OFF ON

The pulse width in one-shot means the bold lined section of a pulse waveform.

EXTERNAL DIMENSIONS & TERMINAL ASSIGNMENTS unit: mm (inch)

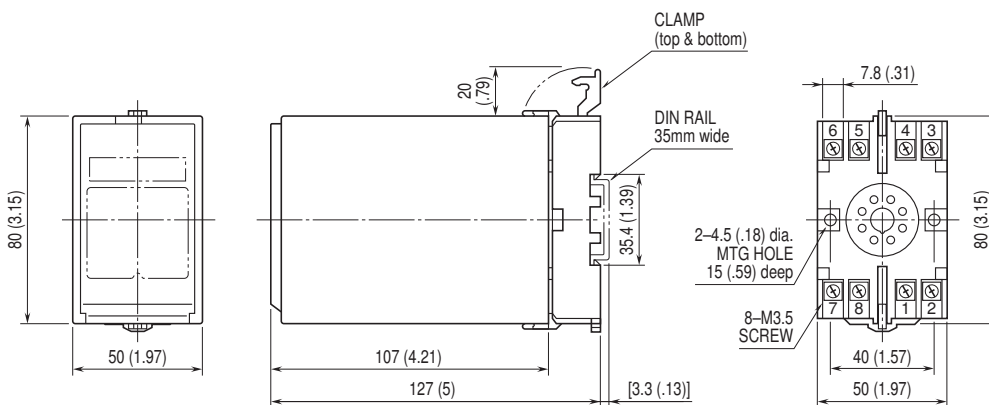

• When mounting, no extra space is needed between units.



SCHEMATIC CIRCUITRY & CONNECTION DIAGRAM

■ OPEN COLLECTOR, MECHANICAL SWITCH, VOLTAGE PULSE, 2-WIRE CURRENT PULSE INPUT

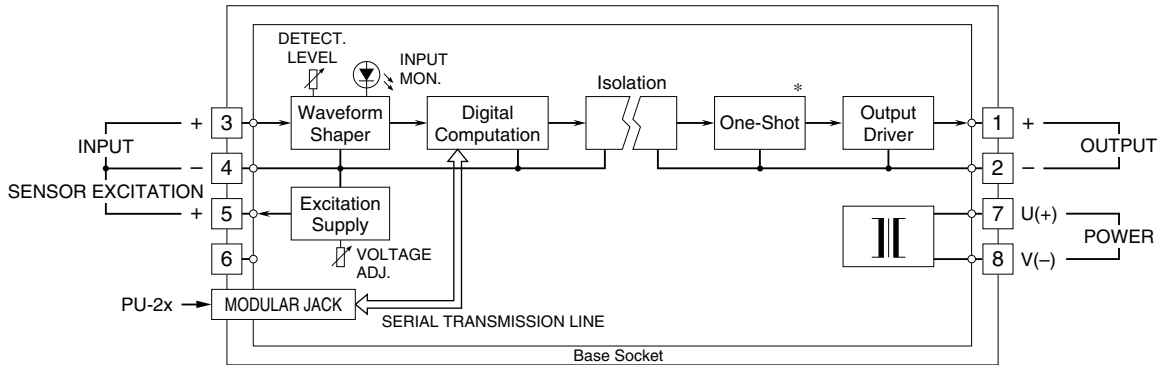

*Deleted with no pulse width conversion type.

Remark: With 24V excitation and open collector/mechanical contact input, the voltage across the terminals 3 - 4, divided in the waveform shaper, is of approx. 16V.

■ RS-422 LINE DRIVER PULSE INPUT

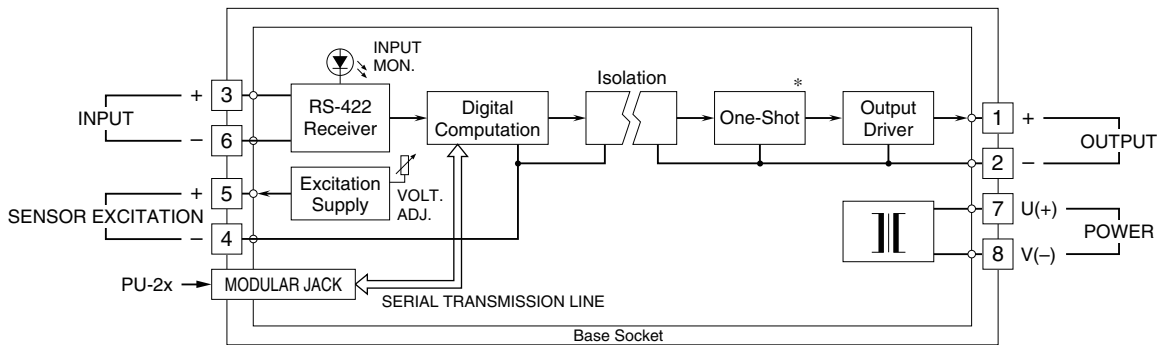

*Deleted with no pulse width conversion type.

Input Connection Examples

■ Open Collector or Mechanical Contact

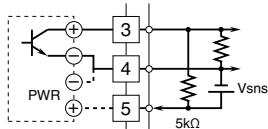

■ Voltage Pulse

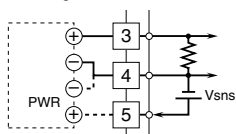

■ RS-422 Line Driver Pulse

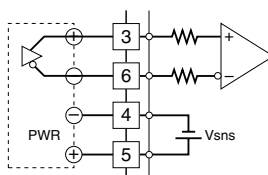

■ 2-Wire Current Pulse

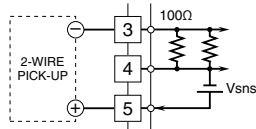

• External DC Supply

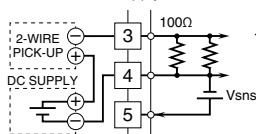

Output Connection Examples

■ Open Collector

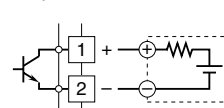

■ Voltage Pulse

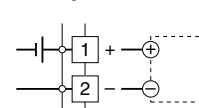

■ Noncontact AC/DC Switch

• AC Powered

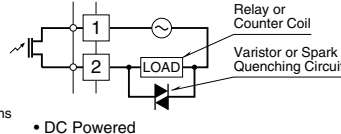

• DC Powered

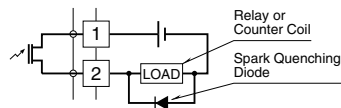

■ RS-422 Line Driver Pulse

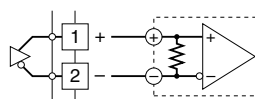

OPERATION

[Example]

Input frequency: 2 Hz

Sampling time: 0.5 sec.



幸託有限公司
XIN TOP CORPORATION

TEL : (02)2598-1199

FAX : (02)2596-2331

E-mail : info@xintop.com

Website : www.xintop.com

Pulse rate: 3/2

Output pulse width: Duty ratio approx. 50 %

Max. output frequency: 1 kHz

1) The JPR2 counts the number of pulses during the sampling time (period). In the example, 1 count in 0.5 sec. time.

2) Converts the number in the preset rate. In the example, $1 \text{ pulse} \times 3/2 = 1.5 \text{ pulses}$

3) Outputs the converted pulses in the next sampling period.

If certain pulses are not output within the time frame due to a fraction or the max. output frequency limit, they are output in the following sampling period. In the example, 1 pulse is output in the second period, two pulses are output in the third to adjust the fraction.

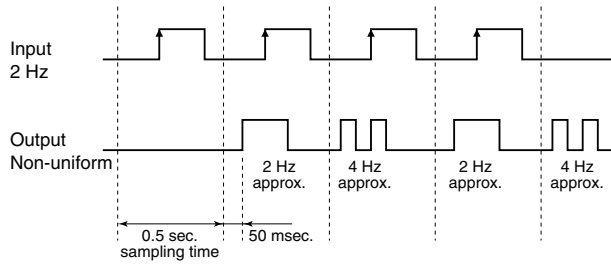

Specifications are subject to change without notice.

