

## Plug-in Signal Conditioners M-UNIT

### FILTER/LAG TRANSMITTER

(field-programmable)

#### Functions & Features

- Providing various filter functions which eliminate unnecessary elements in the input signals
- Microprocessor based
- On-site calibration via hand-held programmer PU-2x
- Field-programmable input range
- Isolation up to 2000 V AC
- High-density mounting

#### Typical Applications

- Level control; eliminating drifts in the input signal caused by pumps

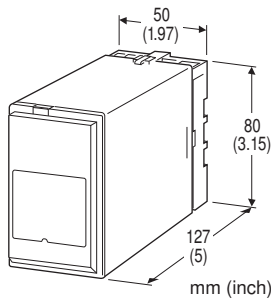

## MODEL: JFT[1]-[2][3]-[4][5]

### ORDERING INFORMATION

- Code number: JFT[1]-[2][3]-[4][5]
- Specify a code from below for each [1] through [5]. (e.g. JFT1-6A-B/Q)
- Use Ordering Information Sheet (No. ESU-1679) to specify parameters. Default setting will be used if not otherwise specified.
- Parameters (See "Functions" section.)
- Special input and output ranges (For codes U1,U2, U3, Z & 0)
- Specify the specification for option code /Q (e.g. /C01/S01)

ITEM	DEFAULT
Sampling cycle: H	0.1
No. of samples to be calculated: N	1 (2 for mean average output filter)
Time constant: T	0.0
Max. rate of positive output change (CP)	200.00
Max. rate of negative output change (CN)	200.00
No. of smallest samples to be cut off (L)	0
No. of largest samples to be cut off (U)	0

### [1] FUNCTION

- 1: Moving average output
- 2: Dead-time computing
- 3: Delay buffer
- 4: Lead-time computing
- 5: Ramp buffer
- 6: Mean average output

### [2] INPUT

#### Current

- A: 4 - 20 mA DC (Input resistance 250 Ω)  
H: 10 - 50 mA DC (Input resistance 100 Ω)

#### Voltage

- 6: 1 - 5 V DC (Input resistance 1 MΩ min.)  
U1: Range ±100 mV; minimum span 3 mV  
U2: Range ±1000 mV; minimum span 30 mV  
U3: Range ±10 V; minimum span 0.3 V

### [3] OUTPUT

#### Current

- A: 4 - 20 mA DC (Load resistance 750 Ω max.)  
B: 2 - 10 mA DC (Load resistance 1500 Ω max.)  
C: 1 - 5 mA DC (Load resistance 3000 Ω max.)  
D: 0 - 20 mA DC (Load resistance 750 Ω max.)  
E: 0 - 16 mA DC (Load resistance 900 Ω max.)  
F: 0 - 10 mA DC (Load resistance 1500 Ω max.)  
G: 0 - 1 mA DC (Load resistance 15 kΩ max.)  
Z: Specify current (See OUTPUT SPECIFICATIONS)

#### Voltage

- 1: 0 - 10 mV DC (Load resistance 10 kΩ min.)  
2: 0 - 100 mV DC (Load resistance 100 kΩ min.)  
3: 0 - 1 V DC (Load resistance 1000 Ω min.)  
4: 0 - 10 V DC (Load resistance 10 kΩ min.)  
5: 0 - 5 V DC (Load resistance 5000 Ω min.)  
6: 1 - 5 V DC (Load resistance 5000 Ω min.)  
4W: -10 - +10 V DC (Load resistance 10 kΩ min.)  
5W: -5 - +5 V DC (Load resistance 5000 Ω min.)  
0: Specify voltage (See OUTPUT SPECIFICATIONS)

### [4] POWER INPUT

#### AC Power

- B: 100 V AC  
C: 110 V AC  
D: 115 V AC  
F: 120 V AC  
G: 200 V AC  
H: 220 V AC  
J: 240 V AC

#### DC Power

- S: 12 V DC  
R: 24 V DC



V: 48 V DC

**[5] OPTIONS**

blank: none

/Q: With options (specify the specification)

**SPECIFICATIONS OF OPTION: Q (multiple selections)****COATING (For the detail, refer to M-System's web site.)**

/CO1: Silicone coating

/CO2: Polyurethane coating

/CO3: Rubber coating

**TERMINAL SCREW MATERIAL**

/SO1: Stainless steel

**RELATED PRODUCTS**

- JX configurator connection kit (model: JXCON)
- Programming Unit (model: PU-2x)

**GENERAL SPECIFICATIONS****Construction:** Plug-in**Connection:** M3.5 screw terminals**Screw terminal:** Chromated steel (standard) or stainless steel**Housing material:** Flame-resistant resin (black)**Isolation:** Input to output to power**Overrange output:** Approx. -10 to +120 % at 1 - 5 V**Zero adjustment:** -5 to +5 % (front)**Span adjustment:** 95 to 105 % (front)**Adjustments:** Programming Unit (model: PU-2x); function and parameters, input range, zero and span, etc.

(Input range can be changed with Codes U1, U2 or U3 and limited within ranges of each code type.)

(Refer to the users manual of JXCON for the adjustments configurable with JXCON.)

**INPUT SPECIFICATIONS**■ **DC Current:**

Shunt resistor attached to the input terminals (0.5 W)

■ **DC Voltage:** -10 - +10 V DC**Minimum span:** 3 mV**Offset:** Max. 3 times span**Input resistance** (Input Range: Input Resistance)**U1:** ±100 mV: 20 kΩ min.**U2:** ±1000 mV: 20 kΩ min.**U3:** ±10 V: 1 MΩ min.

Default setting will be used if not otherwise specified.

**U1:** 0 - 100 mV DC**U2:** 0 - 1 V DC**U3:** 0 - 10 V DC**OUTPUT SPECIFICATIONS**■ **DC Current:** 0 - 20 mA DC**Minimum span:** 1 mA**Offset:** Max. 1.5 times span**Load resistance:** Output drive 15 V max.■ **DC Voltage:** -10 - +20 V DC**Span:** Min. 5 mV, max. 20 V**Offset:** Max. 1.5 times span**Load resistance:** Output drive 1 mA max.; at ≥ 0.5 V**INSTALLATION****Power input**• **AC:** Operational voltage range: rating ±10 %, 50/60 ±2 Hz, approx. 3 VA• **DC:** Operational voltage range: rating ±10 %, ripple 10 %p-p max., approx. 2 W (90 mA at 24 V)**Operating temperature:** -5 to +55°C (23 to 131°F)**Operating humidity:** 30 to 90 %RH (non-condensing)**Mounting:** Surface or DIN rail**Weight:** 350 g (0.77 lb)**PERFORMANCE in percentage of span****Accuracy:** ±0.1 %**Temp. coefficient:** ±0.015 %/°C (±0.008 %/°F)**Response time:** ≤ 0.5 sec. (0 - 90 %) without any function setting**Line voltage effect:** ±0.1 % over voltage range**Insulation resistance:** ≥ 100 MΩ with 500 V DC**Dielectric strength:** 2000 V AC @1 minute (input to output to power to ground)

## DIMENSIONS unit: mm (inch)

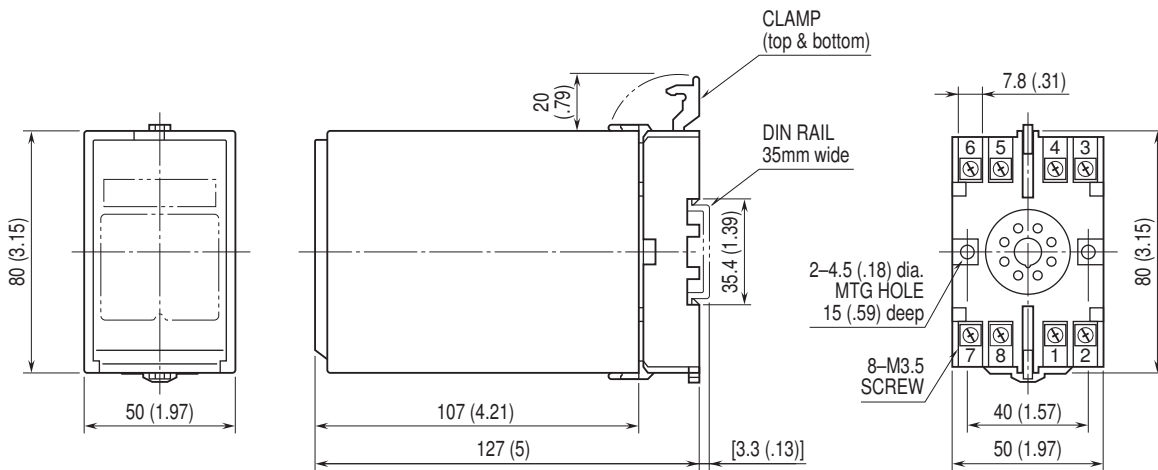

• When mounting, no extra space is needed between units.

## TERMINAL ASSIGNMENTS unit: mm (inch)

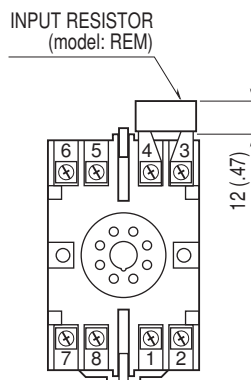

Input shunt resistor attached for current input.

## SCHEMATIC CIRCUITRY & CONNECTION DIAGRAM

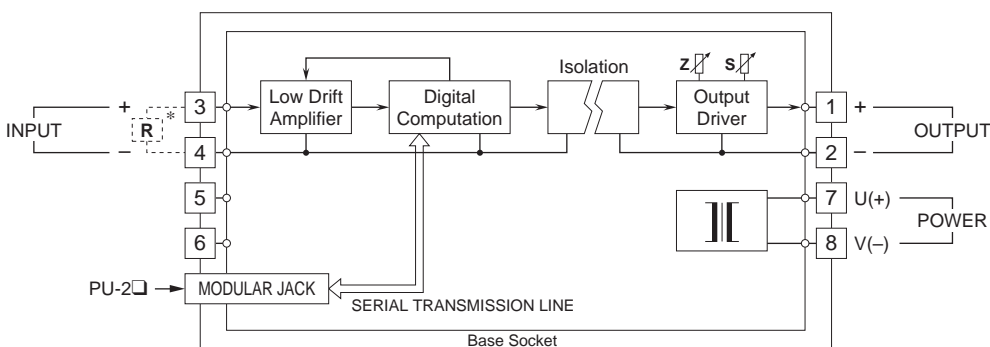

\*Input shunt resistor attached for current input.

## FUNCTIONS

### ■ MOVING AVERAGE OUTPUT

This unit samples input signals every H seconds and outputs proportionally to an average of N numbers of sampled data. When a new input is sampled after another H seconds, it gives up the oldest sample and calculates a new average including the latest sample and outputs proportionally.

- H : sampling cycle  
(0.1 to 100.0 seconds adjustable)
- N : number of samples to be calculated  
(1 to 8 adjustable)

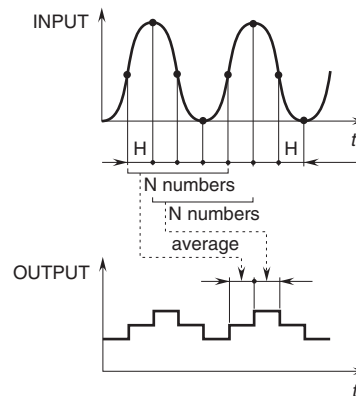

### ■ DEAD-TIME COMPUTING

This unit does not respond to an input signal for a preset dead-time duration. In addition, with adjusting a time constant T, it generates a first order lag output after the dead-time.

$$X_0(s) = \frac{e^{-Ls}}{1 + Ts} X_1(s) + H \times N(s)$$

- X<sub>0</sub> : output
- X<sub>1</sub> : input

Dead Time = H × N (s) (H ≤ T)

- H : sampling cycle  
(0.1 to 100.0 seconds adjustable)
- N : numbers of samples to be calculated  
(1 to 8 adjustable)
- T : time constant  
(0 to 100.0 seconds adjustable)

#### •Step Input with Dead-Time

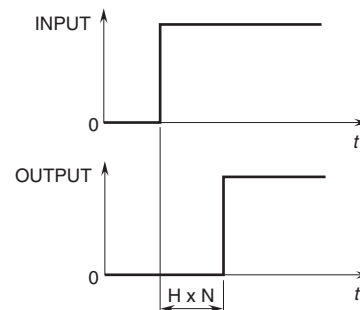

#### •Step Input with Dead-Time Plus Time Constant

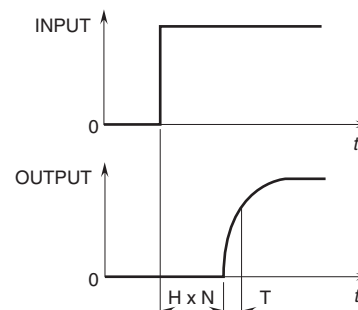

### ■ DELAY BUFFER

This unit generates a first order lag output.

$$X_0(s) = \frac{1}{1 + Ts} X_1(s)$$

- X<sub>0</sub> : output
- X<sub>1</sub> : input
- T : time constant  
(0 to 100.0 second adjustable)

#### •Step Input with Time Constant

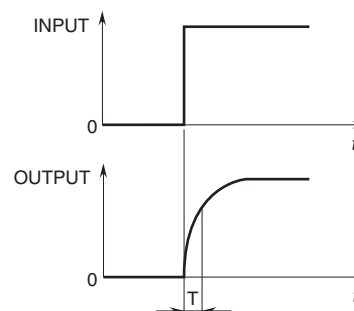

## ■ LEAD-TIME COMPUTING

This unit operates a lead-time equation.

$$X_0(s) = (1 + T s) X_1(s)$$

$X_0$  : output

$X_1$  : input

$T$  : lead-time constant  
(0 to 100.0 seconds adjustable)

## •Step Input with Time Constant (Lead)

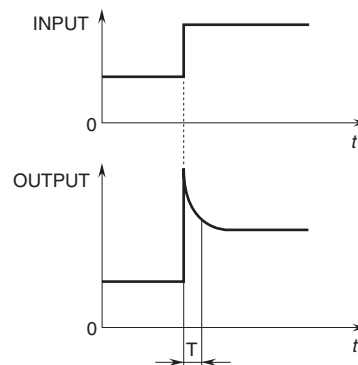

## ■ RAMP BUFFER

This unit's output does not change faster than a preset maximum rate, positive CP and negative CN, no matter how fast its input changes.

CP: maximum rate of positive output change  
(0.00 to 200.00%/second adjustable)

CN: maximum rate of negative output change  
(0.00 to 200.00%/second adjustable)

## •Step Input with Rate-of-Change Limit

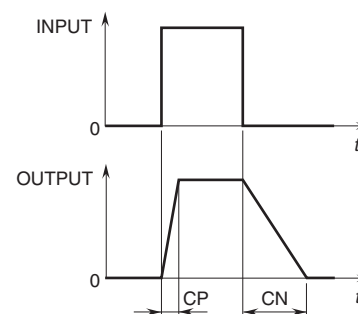

## ■ MEAN AVERAGE OUTPUT

This unit samples input signals every H seconds and, excluding U numbers of largest samples and L numbers of smallest samples, outputs proportionally to an average of the rest  $[N - (U + L)]$  of sampled data. When the number of samples to be calculated equals 0 or less, it outputs an error.

H : sampling cycle  
(0.1 to 100.0 seconds adjustable)

N : number of samples to be calculated  
(2 to 8 adjustable)

U : number of largest samples to be cut off  
(0 to 7 adjustable)

L : number of smallest samples to be cut off  
(0 to 7 adjustable)

## •Example (N=5, U=1, L=1)

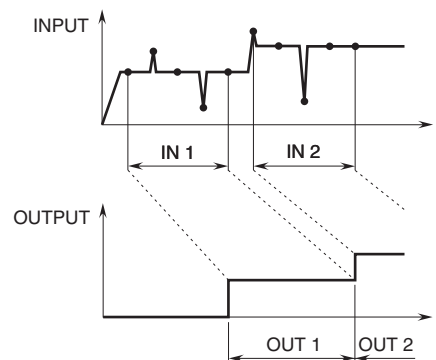

Specifications are subject to change without notice.