

Plug-in Signal Conditioners M-UNIT

ANALOG BACKUP STATION

Functions & Features

- Enables manual loading providing hold/increase/ decrease signals to a device controlled by PID controller
- When the PID controller fails, the JB2 output goes back the preset time period and holds the cascade control signal of that moment (Retroactive function)
- Cascade control loop does not open even when the JB2 itself fails
- Manual control output transits smoothly to the cascade control mode in the preset response time (Sliding-back function)
- Isolated re-transmitted output
- Parameters set via hand-held programmer PU-2x
- Can be driven on battery power supply (35 V DC max.)

Typical Applications

- Backup hold/manual loading for the DCS or computer control output failure

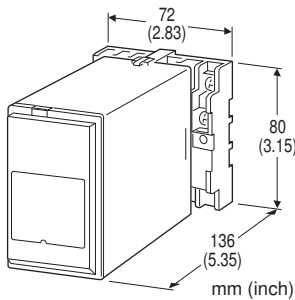

MODEL: JB2-AAA-R1/A[1]

ORDERING INFORMATION

- Code number: JB2-AAA-R1/A[1]
- Specify a code from below for [1].
(e.g. JB2-AAA-R1/A/Q)
- Specify the specification for option code /Q
(e.g. /C01/S01)
- Use Ordering Information Sheet (No. ESU-2642) to specify details of the backup operation mode.
Factory setting (table below) will be used if not otherwise specified.

Manual control mode	1
Man/cas transition response	0.00
Up/down response mode	0
Up/down response time	10.00
High/low alarm mode at cas control	0
Low alarm setpoint	-25.00
High alarm setpoint	125.00
Retroactive time period	0.0
Initial manual control value	0.00
Output after power recovery in manual control mode	-25.00
Output value after power recovery	0

CAS INPUT

Current

A: 4 - 20 mA DC

MV OUTPUT

Current

A: 4 - 20 mA DC

RE-TRANSMITTED OUTPUT

Current

A: 4 - 20 mA DC (Load resistance 350 Ω max.)

POWER INPUT

DC Power

R1: 15 - 35 V DC

(Operational voltage range 15 - 35 V, ripple 10 %p-p max.)

OUTPUT SELECTABLE AFTER POWER RECOVERY

/A: With

[1] OPTIONS

blank: none

/Q: With options (specify the specification)

SPECIFICATIONS OF OPTION: Q (multiple selections)

COATING (For the detail, refer to M-System's web site.)

/C01: Silicone coating

/C02: Polyurethane coating

/C03: Rubber coating

TERMINAL SCREW MATERIAL

/S01: Stainless steel



RELATED PRODUCTS

- JX configurator connection kit (model: JXCON)
- Programming Unit (model: PU-2x)

GENERAL SPECIFICATIONS

Construction: Plug-in

Connection: M3.5 screw terminals

Screw terminal: Chromated steel (standard) or stainless steel

Housing material: Flame-resistant resin (black)

Isolation: CAS input or MV output to contact input or power to re-transmitted output to contact output

Zero adjustment: -5 to +5 % (front)

Span adjustment: 98 to 102 % (front)

Alarm output: RUN contact turns off when the high/low alarm for the CAS input trips.

Indicator LED: RUN output (green), MAN status output (red), UP command (red), DOWN command (red), MAN command (red)

Programming: Programming Unit (model: PU-2x); Sliding-back response time, UP-DOWN response time, alarm, etc. (Refer to the users manual of JXCON for the adjustments configurable with JXCON.)

INPUT SPECIFICATIONS

•CAS Input: 4 - 20 mA DC

Input resistance: 25 Ω in manual control mode

■ **Contact Input:** MAN control command and UP/DOWN command

Sensing: 5 V DC @ 3 mA

Detection levels

ON resistance: $\leq 200 \Omega$, $\leq 0.80 \text{ V}$

OFF resistance: $\geq 100 \text{ k}\Omega$, $\geq 4.95 \text{ V}$

OUTPUT SPECIFICATIONS

■ **MAN Output:** 4 - 20 mA DC

Load resistance

•CAS control mode: Allowable load for CAS signal minus 50 Ω

•MAN control mode: 0 - 750 Ω

• **Relay Output:** MAN status and RUN output; 120 V AC @ 1 A or 24 V DC @ 1 A

Maximum switching voltage: 250 V AC or 30 V DC

Maximum switching power: 120 VA or 24 W

Minimum load: 5 V DC @100 mA

Mechanical life: 2×10^7 cycles

INSTALLATION

Power consumption

CAS mode: Approx. 120 mA at 24 V

MAN mode: Approx. 180 mA at 24 V

Operating temperature: -5 to +55°C (23 to 131°F)

Operating humidity: 30 to 90 %RH (non-condensing)

Mounting: Surface or DIN rail

Weight: 450 g (0.99 lb)

PERFORMANCE in percentage of span

Alarm setting accuracy: $\pm 0.5 \%$

Re-transmitted output accuracy: $\pm 0.4 \%$

CAS to MAN or MAN to CAS switching accuracy: $\pm 0.5 \%$
MV output terminal is open during the time switching the internal relay (≤ 10 msec.) when turning CAS to MAN or MAN to CAS mode.

Temp. coefficient: $\pm 0.015 \%/^{\circ}\text{C}$ ($\pm 0.008 \%/^{\circ}\text{F}$)

Re-transmitted output response time: ≤ 20 msec.

Output memory at power OFF: E²PROM (non-volatile memory)

Insulation resistance: $\geq 100 \text{ M}\Omega$ with 500 V DC

Dielectric strength: 1000 V AC @ 1 minute (CAS input or MV output to contact input or power to retransmitted output to contact output)

1500 V AC @ 1 minute (CAS input or MV output or contact input or power or re-transmitted output or contact output to ground)

OPERATING MODES

■ CASCADE CONTROL MODE

The JB2 allows the CAS input (cascade control signal) from the PID controller to pass through at the MV output terminals.

■ MANUAL CONTROL MODE

When the external MAN command contact is closed, the JB2 turns on to manual control mode. Actual output signal is determined by following three operation modes:

MODE 1: Holds the CAS control signal at the moment of the MAN command.

MODE 2: Goes back the preset time period and hold the CAS control signal at that moment.

MODE 3: Holds a specific value preset by the Programming Unit (PU-2x).

In this mode, the output can be manipulated with external UP or DOWN commands.

When the MAN command contact is opened, the CAS control signal is recovered with smooth transition.

■ TRANSITION FROM MAN TO CAS CONTROL MODE

The JB2 increases/decreases the MV output until it reaches to the same value as the CAS control signal, and turns on to CAS control mode. The response time constant can be set/changed with the PU-2x.



If the external command contact is closed during the transition, the JB2 output holds the signal of this moment and turns on to MAN control mode.

■ JB2 ACTIONS AT POWER RECOVERY

The actions at power recovery can be switched by actions and settings at the moment of power failure.

a) MAN command status is OFF at recovery.
CAS mode

b) MAN command status is ON at recovery.

- Output value after power on is "FIXED VALUE".

Manual control starts with fixed output value.

- Output value after power on is "HOLD VALUE".

Manual control starts with output value at the moment of power failure.

(Approx. 0.3 second is required to switch from CAS to MAN when the power supply is recovered. Refer to the instruction manual.)

■ DIFFERENCE BETWEEN JB AND JB2/A

Means to back up the output value is different.

- JB: STATIC RAM (A large capacitance capacitor holds the value until the capacitor is discharged.)
- JB2: E²PROM (Output value is stored at E²PROM and held until the next rewrite.)

Therefore, the output value at power recovery during "MAN" control mode is as shown below.

- JB: When recovering within the memory time, JB outputs the value at the moment of power failure.

When recovering without the memory time, JB outputs the fixed value.

- JB2/A: The output value at power recovery is selectable, whether the value at the moment of power failure or the fixed value.

■ COMPATIBILITY BETWEEN JB2 AND JB2/A

For JB2/A, the operation at power recovery is selectable.

When JB2 (without "/A") is replaced with JB2/A compatibly, set JB2/A according to the instruction manual.



EXTERNAL VIEW

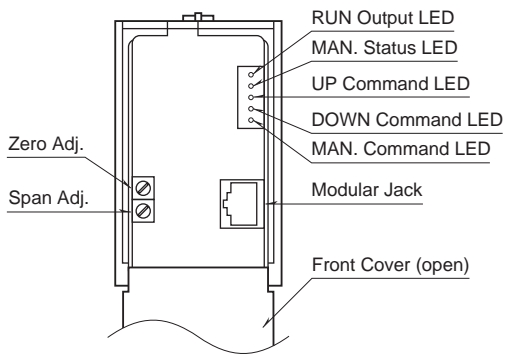

EXTERNAL DIMENSIONS & TERMINAL ASSIGNMENTS unit: mm (inch)

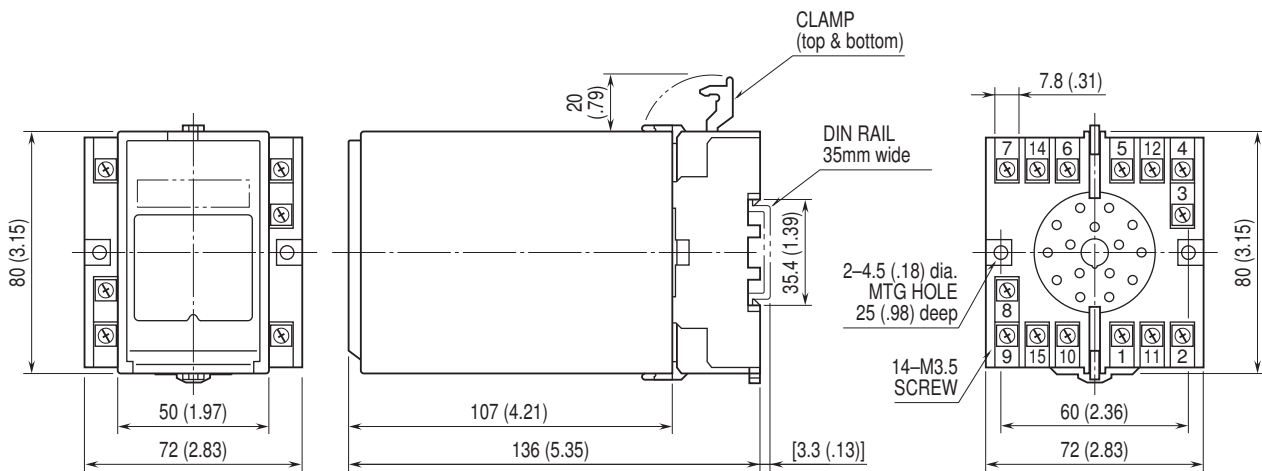

• When mounting, no extra space is needed between units.

SCHEMATIC CIRCUITRY & CONNECTION DIAGRAM

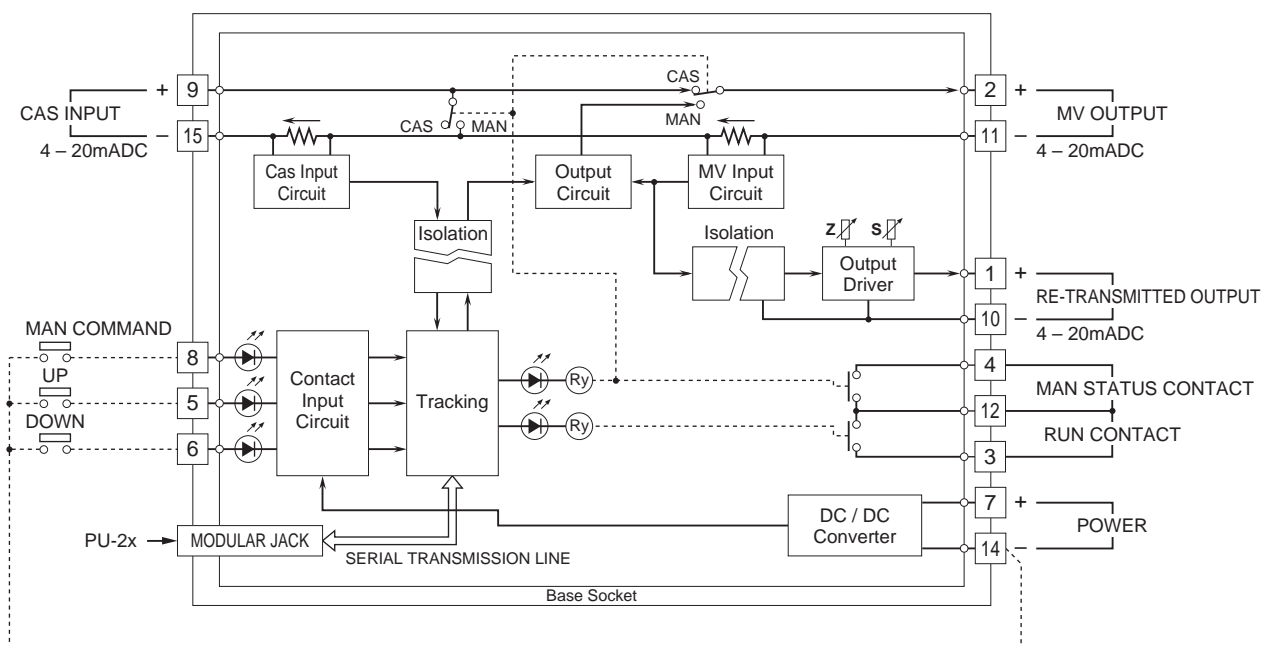

APPLICATION EXAMPLES

• Output backup for a PID controller in the DCS system

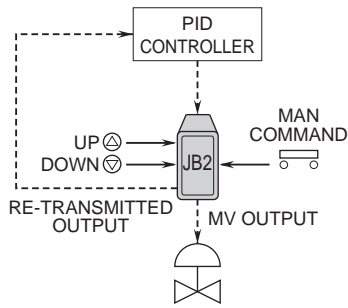

• Control loop utilizing pulse duration output from a computer

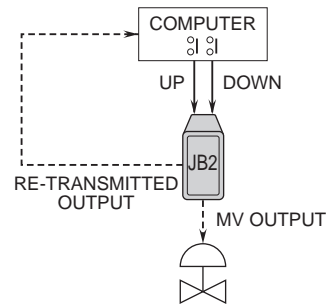

Specifications are subject to change without notice.

