

## Plug-in Signal Conditioners M-UNIT

### DC/FREQUENCY CONVERTER

(field-programmable)

#### Functions & Features

- Providing a pulse rate output in proportion to DC input signal
- Parameters are field-programmable via hand-held programmer PU-2x
- Isolation up to 2000 V AC
- High-density mounting

#### Typical Applications

- Monitoring & control of power supply system
- Quick countermeasure applicable even in failure or in sudden voltage change

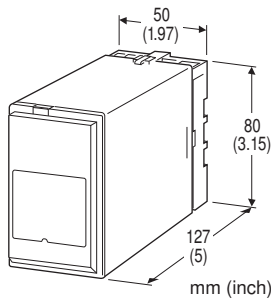

### MODEL: JAPD2-[1][2]-[3][4]

#### ORDERING INFORMATION

- Code number: JAPD2-[1][2]-[3][4]
- Specify a code from below for each [1] through [4]. (e.g. JAPD2-6A-S/Q)
- Special input range (For codes Z & 0)
- Use Ordering Information Sheet (No. ESU-1571).
- Default setting (table below) will be used if not otherwise specified.
- Specify the specification for option code /Q (e.g. /C01/S01)

ITEM	DEFAULT
Output zero frequency	0 kHz
Output span frequency	1 kHz (10 Hz for output code R)
Alarm setpoint	100.00%
Alarm hysteresis	1.00%
Alarm mode	No alarm
Power ON-delay time	3.0 sec.

#### [1] INPUT

##### Current

- A: 4 - 20 mA DC (Input resistance 250 Ω)
- A1: 4 - 20 mA DC (Input resistance 50 Ω)
- B: 2 - 10 mA DC (Input resistance 500 Ω)
- C: 1 - 5 mA DC (Input resistance 1000 Ω)
- D: 0 - 20 mA DC (Input resistance 50 Ω)
- E: 0 - 16 mA DC (Input resistance 62.5 Ω)
- F: 0 - 10 mA DC (Input resistance 100 Ω)
- G: 0 - 1 mA DC (Input resistance 1000 Ω)
- H: 10 - 50 mA DC (Input resistance 100 Ω)
- Z: Specify current (See INPUT SPECIFICATIONS)

##### Voltage

- 1: 0 - 10 mV DC (Input resistance 10 kΩ min.)
- 2: 0 - 100 mV DC (Input resistance 100 kΩ min.)
- 3: 0 - 1 V DC (Input resistance 1 MΩ min.)
- 4: 0 - 10 V DC (Input resistance 1 MΩ min.)
- 5: 0 - 5 V DC (Input resistance 1 MΩ min.)
- 6: 1 - 5 V DC (Input resistance 1 MΩ min.)
- 4W: -10 - +10 V DC (Input resistance 1 MΩ min.)
- 0: Specify voltage (See INPUT SPECIFICATIONS)

#### [2] OUTPUT

- A: Open collector
- M: 5 V pulse
- N: 12 V pulse
- P: 24 V pulse
- J: RS-422 line driver pulse
- R: AC/DC switch

#### [3] POWER INPUT

##### AC Power

- M2: 100 - 240 V AC

##### DC Power

- S: 12 V DC
- R: 24 V DC
- P: 110 V DC

#### [4] OPTIONS

blank: none

/Q: With options (specify the specification)

#### SPECIFICATIONS OF OPTION: Q (multiple selections)

**COATING (For the detail, refer to M-System's web site.)**

- /C01: Silicone coating
- /C02: Polyurethane coating
- /C03: Rubber coating

#### TERMINAL SCREW MATERIAL

- /S01: Stainless steel



## RELATED PRODUCTS

- JX configurator connection kit (model: JXCON)
- Programming Unit (model: PU-2x)

## GENERAL SPECIFICATIONS

**Construction:** Plug-in  
**Connection:** M3.5 screw terminals  
**Screw terminal:** Chromated steel (standard) or stainless steel  
**Housing material:** Flame-resistant resin (black)  
**Isolation:** Input to alarm output to output to power  
**Zero adjustment:** -5 to +5 % (front)  
**Span adjustment:** 95 to 105 % (front)  
**Alarm output:** Turns on when the input goes above (high) or below (low) setpoint  
**Alarm setpoint:** -5 - +105 %  
**Alarm deadband (hysteresis):** 0 - 20 %  
**Output monitor LED:** Red LED turns on when the output is ON or high.  
**Power ON delay time:** 2.0 to 1000.0 sec.  
**Adjustments:** Programming Unit (model: PU-2x); output frequency (zero and span), alarm, Power ON delay time, etc. (Refer to the users manual of JXCON for the adjustments configurable with JXCON.)

## INPUT SPECIFICATIONS

■ **DC Current:**  
 Shunt resistor attached to the input terminals (0.5 W)  
 Specify input resistance value for code Z.  
 ■ **DC Voltage:** -300 - +300 V DC  
**Minimum span:** 10 mV  
**Offset:** Max. 1.5 times span  
**Input resistance**  
 Span 10 - 100 mV :  $\geq 10 \text{ k}\Omega$   
 Span 0.1 - 1 V :  $\geq 100 \text{ k}\Omega$   
 Span  $\geq 1 \text{ V}$  :  $\geq 1 \text{ M}\Omega$

## OUTPUT SPECIFICATIONS

**Frequency range:** 100 mHz to 10 kHz (RNG1 to RNG6)  
 [ Range name : Available frequency / minimum output frequency ]  
 RNG1 10 kHz: 0 - 20 kHz / 5 Hz  
 RNG2 1 kHz: 0 - 2 kHz / 0.5 Hz  
 RNG3 100 Hz: 0 - 200 Hz / 50 mHz  
 RNG4 10 Hz: 0 - 20 Hz / 5 mHz  
 RNG5 1 Hz: 0 - 2 Hz / 0.5 mHz  
 RNG6 100 mHz: 0 - 200 mHz / 0.05 mHz  
**Min. span:** 20 % of available frequency range  
**Duty ratio:** 50 %  
 ■ **Open Collector:** 50 V DC @50 mA (resistive load)  
**Saturation voltage:** 0.6 V DC

## ■ Voltage Pulse

**H level:** Rating 5, 12 or 24 V  $\pm 10 \%$

**L level:**  $\leq 0.5 \text{ V}$

**Load resistance:**  $\geq 1 \text{ k}\Omega$  (5V),  $\geq 2.4 \text{ k}\Omega$  (12 V),  $\geq 4.8 \text{ k}\Omega$  (24 V)

■ **Noncontact AC/DC Switch:** 120 V AC or 120 V DC @200 mA (resistive load)

**ON resistance:** 3  $\Omega$  max.

**Rise time:** 5 msec.

**Sink time:** 3 msec.

## ■ RS-422 Line Driver Pulse

**Transmitter:** Conforms to RS-422

## ■ Relay Contact:

100 V AC @ 1 A ( $\cos \theta = 1$ )

120 V AC @ 1 A ( $\cos \theta = 1$ )

240 V AC @ 0.5 A ( $\cos \theta = 1$ )

30 V DC @ 1 A (resistive load)

**Maximum switching voltage:** 380 V AC or 125 V DC

**Maximum switching power:** 120 VA or 30 W

**Minimum load:** 5 V DC @ 10 mA

**Mechanical life:**  $5 \times 10^7$  cycles (300 cycle/minute)

## INSTALLATION

### Power input

#### •AC:

Operational voltage range 85 - 264 V, 47 - 66 Hz;

3.2 VA at 100 V

5.1 VA at 200 V

6.9 VA at 264 V

•**DC:** Operational voltage range: rating  $\pm 10 \%$ , or 85 - 150 V for 110 V rating (ripple 10 % p-p max.)

approx. 2.5 W (100 mA at 24 V)

**Operating temperature:** -5 to +55°C (23 to 131°F)

**Operating humidity:** 30 to 90 %RH (non-condensing)

**Mounting:** Surface or DIN rail

**Weight:** 280 g (0.62 lb)

## PERFORMANCE in percentage of span

### Accuracy

**Output 10 kHz range:**  $\pm 0.3 \%$

**Output  $\leq 1$  kHz range:**  $\pm 0.1 \%$

**Alarm setpoint accuracy:**  $\pm 0.1 \%$

**Temp. coefficient:**  $\pm 0.015 \%/^{\circ}\text{C}$  ( $\pm 0.008 \%/^{\circ}\text{F}$ )

**Response time:** 0.3 sec. + (one cycle at 100 % output)

Time required from a step input (0 - 100 %) to the first pulse output.

**Line voltage effect:**  $\pm 0.1 \%$  over voltage range

**Insulation resistance:**  $\geq 100 \text{ M}\Omega$  with 500 V DC

**Dielectric strength:** 2000 V AC @ 1 minute (input to alarm output to output to power to ground)



## EXTERNAL VIEW

DO NOT change the Output Voltage Adjuster.

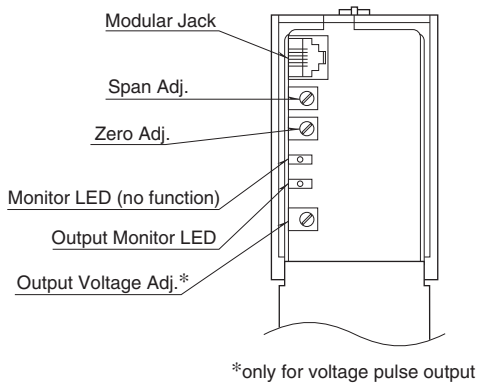

## DIMENSIONS unit: mm (inch)

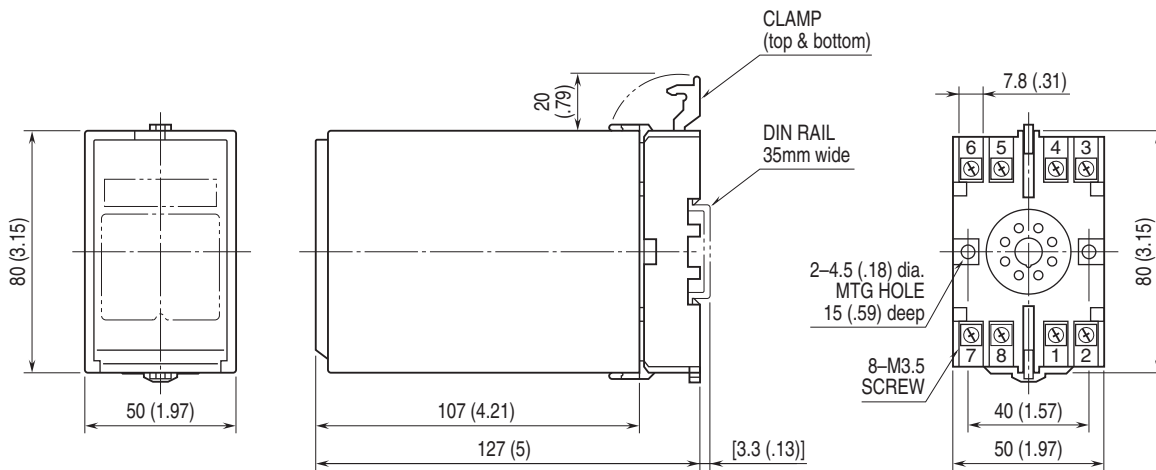

• When mounting, no extra space is needed between units.

## TERMINAL ASSIGNMENTS unit: mm (inch)

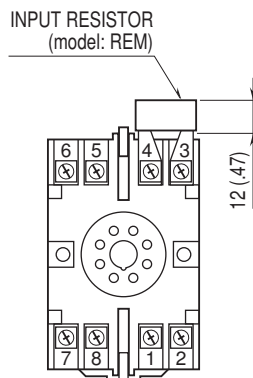

Input shunt resistor attached for current input.

## SCHEMATIC CIRCUITRY & CONNECTION DIAGRAM

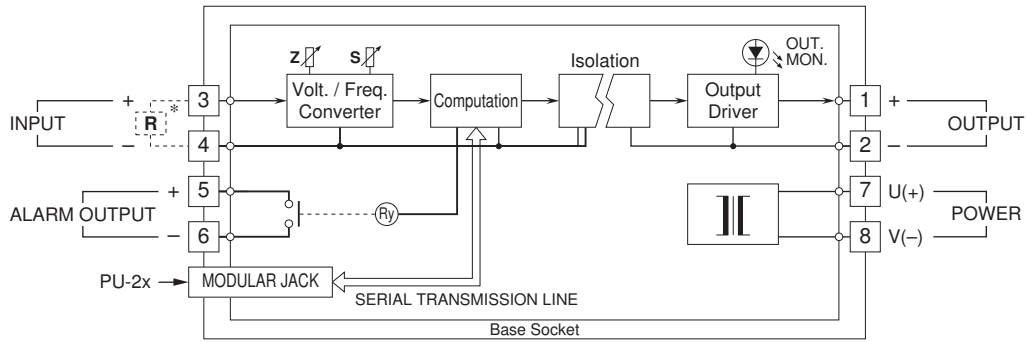

\*Input shunt resistor attached for current input.

### Output Connection Examples

#### Open Collector

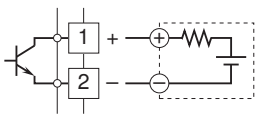

#### RS-422 Line Driver Pulse

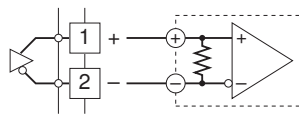

#### AC/DC Switch

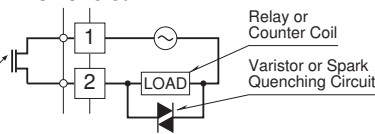

#### Voltage Pulse

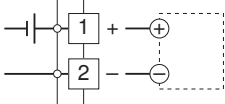

#### DC Powered

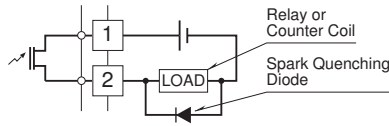

Specifications are subject to change without notice.