

Space-saving Plug-in Signal Conditioners H-UNIT

FILTER/LAG TRANSMITTER

(field-programmable)

Functions & Features

- Providing various filter functions which eliminate unnecessary elements in the input signals
- Microprocessor based
- On-site calibration via hand-held programmer PU-2x
- Field-programmable input range
- High-density mounting

Typical Applications

- Level control; eliminating drifts in the input signal caused by pumps

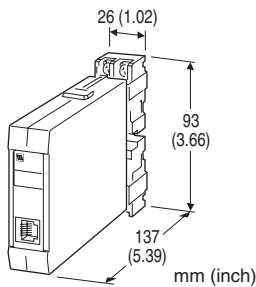

MODEL: HJFT[1]-[2][3]-R[4]

ORDERING INFORMATION

- Code number: HJFT-[1]-[2][3]-R[4]
- Specify a code from below for each [1] through [4]. (e.g. HJFT1-6A-R/Q)
- Default setting will be used if not otherwise specified. Use Ordering Information Sheet (No. ESU-1679) to specify parameters.
- Parameters (See "Functions" section)
- Special input range (For codes U1, U2, U3)
- Specify the specification for option code /Q (e.g. /C01/S01)

[1] FUNCTION

- 1: Moving average output
- 2: Dead-time computing
- 3: Delay buffer
- 4: Lead-time computing
- 5: Ramp buffer
- 6: Mean average output

[2] INPUT

Current

- A: 4 - 20 mA DC (Input resistance 250 Ω)
- H: 10 - 50 mA DC (Input resistance 100 Ω)

Voltage

- 6: 1 - 5 V DC (Input resistance 1 MΩ min.)
- U1: Range ±100 mV; minimum span 3 mV
- U2: Range ±1000 mV; minimum span 30 mV
- U3: Range ±10 V; minimum span 0.3 V

[3] OUTPUT

Current

- A: 4 - 20 mA DC (Load resistance 600 Ω max.)

Voltage

- 6: 1 - 5 V DC (Load resistance 500 Ω min.)

POWER INPUT

DC Power

- R: 24 V DC
- (Operational voltage range 24 V ±10 %, ripple 10 %p-p max.)

[4] OPTIONS

- blank: none
- /Q: With options (specify the specification)

SPECIFICATIONS OF OPTION: Q (multiple selections)

COATING (For the detail, refer to M-System's web site.)

- /C01: Silicone coating
- /C02: Polyurethane coating
- /C03: Rubber coating

TERMINAL SCREW MATERIAL

- /S01: Stainless steel

RELATED PRODUCTS

- JX configurator connection kit (model: JXCON)
- Programming Unit (model: PU-2x)

GENERAL SPECIFICATIONS

- Construction: Plug-in
- Connection: M3.5 screw terminals (torque 0.8 N·m)
- Screw terminal: Nickel-plated steel
- Housing material: Flame-resistant resin (black)
- Isolation: Input to output to power
- Overrange output: Approx. -10 to +120 % at 1 - 5 V
- Adjustments: Programming Unit (model: PU-2x); function and parameters, input range, zero and span, etc. (Input range can be changed with Codes U1, U2 or U3 and limited within ranges of each code type.) (Refer to the users manual of JXCON for the adjustments)



configurable with JXCON.)

INPUT SPECIFICATIONS

■ DC Current:

Shunt resistor attached to the input terminals (0.5 W)

■ DC Voltage: -10 - +10 V DC

Minimum span: 3 mV

Offset: Max. 3 times span

Input resistance (Input Range: Input Resistance)

U1: ±100 mV: 20 kΩ min.

U2: ±1000 mV: 20 kΩ min.

U3: ±10 V: 1 MΩ min.

Default setting will be used if not otherwise specified.

U1: 0 - 100 mV DC

U2: 0 - 1 V DC

U3: 0 - 10 V DC

INSTALLATION

Current consumption: Approx. 90 mA

Operating temperature: -5 to +55°C (23 to 131°F)

Operating humidity: 30 to 90 %RH (non-condensing)

Mounting: Surface or DIN rail; Standard Rack Mounting

Frame BX-16H available

Weight: 220 g (0.49 lbs)

PERFORMANCE in percentage of span

Accuracy: ±0.1 %

Temp. coefficient: ±0.015 %/°C (±0.008 %/°F)

Response time: ≤ 0.5 sec. (0 - 90 %) without any function setting

Line voltage effect: ±0.1 % over voltage range

Insulation resistance: ≥ 100 MΩ with 500 V DC

Dielectric strength: 500 V AC @ 1 minute

(input to output to power)

1500 V AC @ 1 minute (input or output or power to ground)

DIMENSIONS unit: mm (inch)

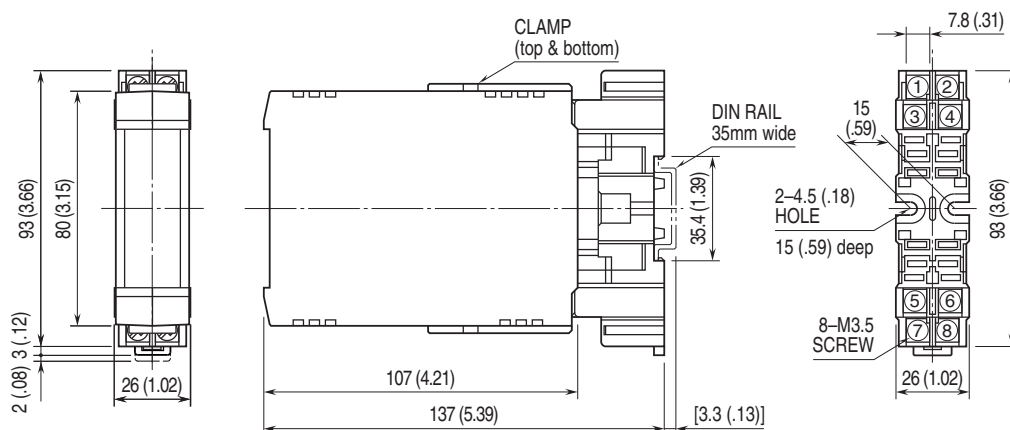

•When mounting, no extra space is needed between units.



幸託有限公司
XIN TOP CORPORATION

TEL : (02)2598-1199
FAX : (02)2596-2331

E-mail : info@xintop.com
Website : www.xintop.com

TERMINAL ASSIGNMENTS unit: mm (inch)

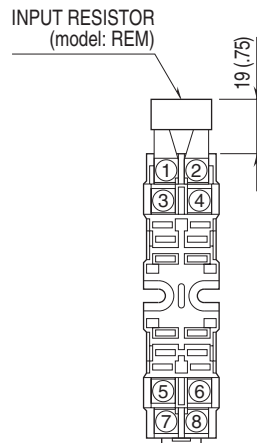

Input shunt resistor attached for current input.

SCHEMATIC CIRCUITRY & CONNECTION DIAGRAM

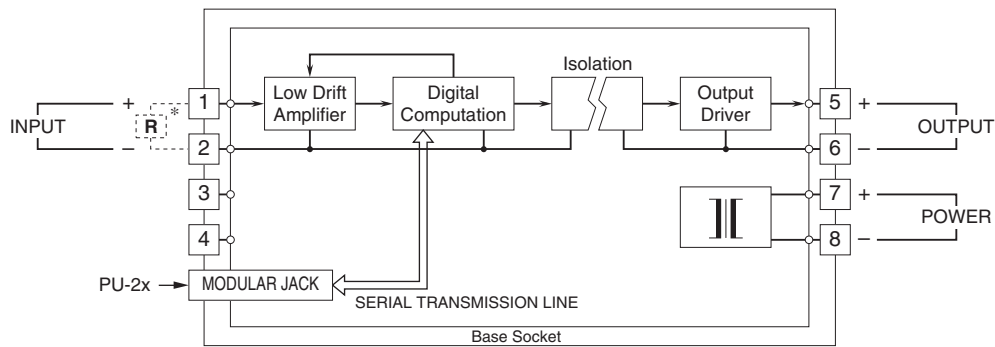

*Input shunt resistor attached for current input.

FUNCTIONS

MOVING AVERAGE OUTPUT

This unit samples input signals every H seconds and outputs proportionally to an average of N numbers of sampled data. When a new input is sampled after another H seconds, it gives up the oldest sample and calculates a new average including the latest sample and outputs proportionally.

- H : sampling cycle
(0.1 to 100.0 seconds adjustable)
- N : number of samples to be calculated
(1 to 8 adjustable)

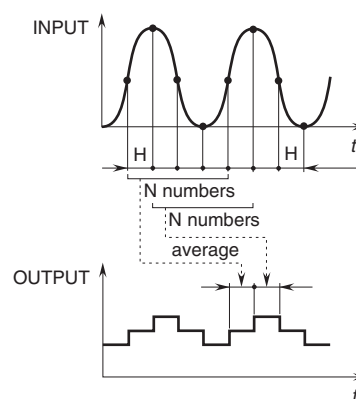

■ DEAD-TIME COMPUTING

This unit does not respond to an input signal for a preset dead-time duration. In addition, with adjusting a time constant T , it generates a first order lag output after the dead-time.

$$X_0(s) = \frac{e^{-Ls}}{1 + Ts} X_1(s) + H \times N(s)$$

X_0 : output

X_1 : input

Dead Time = $H \times N$ (s) ($H \leq T$)

H : sampling cycle

(0.1 to 100.0 seconds adjustable)

N : numbers of samples to be calculated

(1 to 8 adjustable)

T : time constant

(0 to 100.0 seconds adjustable)

•Step Input with Dead-Time

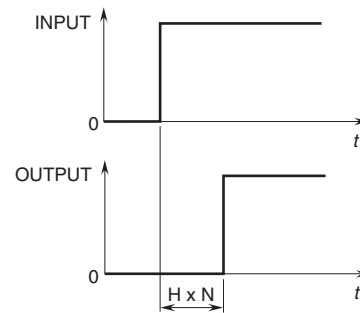

•Step Input with Dead-Time Plus Time Constant

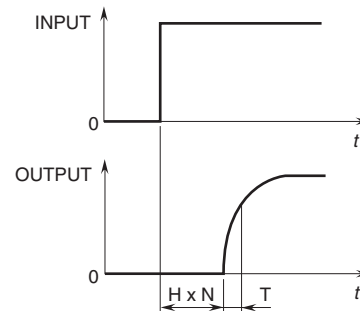

•Step Input with Time Constant

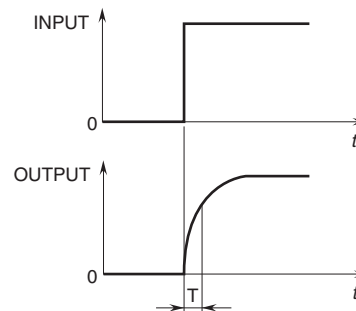

•Step Input with Time Constant (Lead)

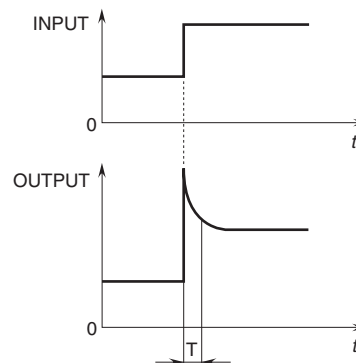

■ DELAY BUFFER

This unit generates a first order lag output.

$$X_0(s) = \frac{1}{1 + Ts} X_1(s)$$

X_0 : output

X_1 : input

T : time constant

(0 to 100.0 second adjustable)

■ LEAD-TIME COMPUTING

This unit operates a lead-time equation.

$$X_0(s) = (1 + Ts) X_1(s)$$

X_0 : output

X_1 : input

T : lead-time constant

(0 to 100.0 seconds adjustable)

■ RAMP BUFFER

This unit's output does not change faster than a preset maximum rate, positive CP and negative CN, no matter how fast its input changes.

- CP: maximum rate of positive output change
(0.00 to 200.00%/second adjustable)
- CN: maximum rate of negative output change
(0.00 to 200.00%/second adjustable)

■ MEAN AVERAGE OUTPUT

This unit samples input signals every H seconds and, excluding U numbers of largest samples and L numbers of smallest samples, outputs proportionally to an average of the rest $[N - (U + L)]$ of sampled data. When the number of samples to be calculated equals 0 or less, it outputs an error.

- H : sampling cycle
(0.1 to 100.0 seconds adjustable)
- N : number of samples to be calculated
(2 to 8 adjustable)
- U : number of largest samples to be cut off
(0 to 7 adjustable)
- L : number of smallest samples to be cut off
(0 to 7 adjustable)

•Step Input with Rate-of-Change Limit

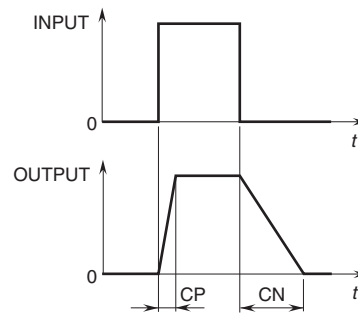

•Example (N=5, U=1, L=1)

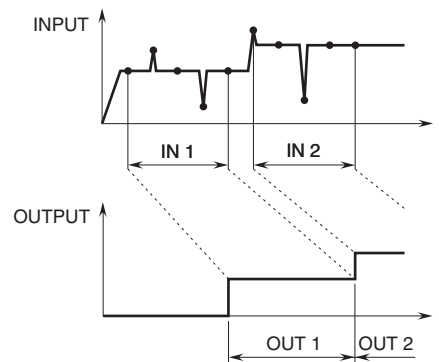

Specifications are subject to change without notice.