

Space-saving Plug-in Signal Conditioners H-UNIT

CURRENT LOOP SUPPLY

(linearizing; field-programmable)

Functions & Features

- Powering a 4 – 20 mA DC current loop
- Microprocessor based
- Shortcircuit protection
- Applicable to smart transmitters
- Field-programmable linearization data
- Loop testing via hand-held programmer PU-2x
- High-density mounting

Typical Applications

- Various 2-wire transmitters
- Providing isolation and linearization for a 2-wire temperature transmitter
- Linearizing weir flowmeter output to provide a linear-to-volume signal
- Linearizer application (4 – 20 mA input)
- Square root extraction for differential pressure transmitter

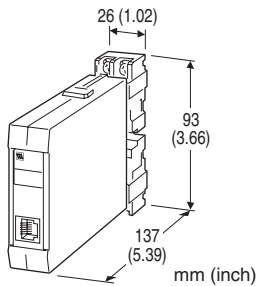

MODEL: HJDL-A[1][2]-R[3]

ORDERING INFORMATION

- Code number: HJDL-A[1][2]-R[3]

Specify a code from below for each [1] through [3].

(e.g. HJDL-A1A-R/Q)

- Linearization data

Code 1 segment data: Use Ordering Information Sheet (No. ESU-1669) to specify linearization data.

Code 3 T/C, Code 4 RTD: Specify input sensor type and temperature range.

Default setting (following table) will be used if not otherwise specified.

No linearization data will be programmed if you don't specify type of linearization and required data.

- Specify the specification for option code /Q (e.g. /C01/S01)

LINEARIZATION CODE	DEFAULT
1: Segment data	Linear
2: Square root extraction	—
3: Thermocouple	K 0 – 1000°C
4: RTD	Pt 100 0 – 100°C

INPUT

Current

A: 4 – 20 mA DC (Input resistance 250 Ω)

[1] LINEARIZATION

0: None

1: Segment data

2: Square root extraction

3: Thermocouple

4: RTD

[2] OUTPUT

Current

A: 4 – 20 mA DC (Load resistance 600 Ω max.)

Voltage

6: 1 – 5 V DC (Load resistance 500 Ω min.)

POWER INPUT

DC Power

R: 24 V DC

(Operational voltage range 24 V ±10 %, ripple 10 %p-p max.)

[3] OPTIONS

blank: none

/Q: With options (specify the specification)

SPECIFICATIONS OF OPTION: Q (multiple selections)

COATING (For the detail, refer to M-System's web site.)

/C01: Silicone coating

/C02: Polyurethane coating

/C03: Rubber coating

TERMINAL SCREW MATERIAL

/S01: Stainless steel

RELATED PRODUCTS

- JX configurator connection kit (model: JXCON)
- Programming Unit (model: PU-2x)

GENERAL SPECIFICATIONS

Construction: Plug-in

Connection: M3.5 screw terminals (torque 0.8 N·m)



Screw terminal: Nickel-plated steel

Housing material: Flame-resistant resin (black)

Isolation: Input to output to power

Overrange output: Approx. -10 to +120 % at 1 - 5 V

Linearization: 16 points max. represented as percentage of full-scale

Adjustments: Programming Unit (model: PU-2x); linearization data, zero and span, simulating output, etc. (Refer to the users manual of JXCON for the adjustments configurable with JXCON.)

SUPPLY OUTPUT

Output voltage: 24 - 28 V DC with no load

Current rating: ≤ 22 mA DC

• **Shortcircuit Protection**

Current limited: 30 mA max.

Protected time duration: No limit

INPUT SPECIFICATIONS

■ **DC Current:** Input resistor incorporated

LINEARIZATION

• **No linearization:** The output is proportional to the input.

• **Segment data:** 16 points (15 segments) max. within the range of -15.00 to +115.00 % input or output represented as percentage of fullscale

• **Square root extraction**

Low-end cutout: 5 % (output); curve characteristics as in the figure below

■ Square root extraction

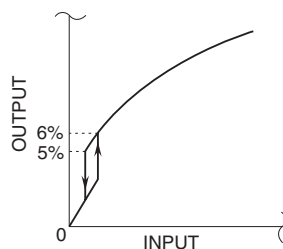

• Thermocouple linearizable range

T/C	USABLE RANGE	
	°C	°F
(PR)	0 to 1760	32 to 3200
K (CA)	-270 to +1370	-454 to +2498
E (CRC)	-270 to +1000	-454 to +1832
J (IC)	-210 to +1200	-346 to +2192
T (CC)	-270 to +400	-454 to +752
B (RH)	0 to 1820	32 to 3308
R	-50 to +1760	-58 to +3200
S	-50 to +1760	-58 to +3200

Remark: For the temperatures that range below 0 °C, the transmitter may partially not satisfy the described accuracy. Consult factory.

• RTD linearizable range

RTD	USABLE RANGE	
	°C	°F
JPt 100 (JIS '89)	-200 to +500	-328 to +932
Pt 100 (JIS '89)	-200 to +650	-328 to +1202
Pt 100 (JIS '97/IEC)	-200 to +650	-328 to +1202
Pt 50Ω (JIS '81)	-200 to +500	-328 to +932
Ni 508.4Ω	-50 to +200	-58 to +392

Remark: Pt 100 (JIS '89) is deviated from Pt 100 (JIS '97) only within the described accuracy.

INSTALLATION

Current consumption: Approx. 95 mA

Operating temperature: -5 to +55°C (23 to 131°F)

Operating humidity: 30 to 90 %RH (non-condensing)

Mounting: Surface or DIN rail; Standard Rack Mounting

Frame BX-16H available

Weight: 220 g (0.49 lbs)

PERFORMANCE in percentage of span

Accuracy: ±0.1 % with segment gain ≤ 1 [±0.1 % × gain] with segment gain ≥ 1

Temp. coefficient: ±0.015 %/°C (±0.008 %/°F)

Response time: ≤ 0.5 sec. (0 - 90 %)

Line voltage effect: ±0.1 % over voltage range

Insulation resistance: ≥ 100 MΩ with 500 V DC

Dielectric strength: 500 V AC @ 1 minute

(input to output to power)

1500 V AC @ 1 minute (input or output or power to ground)



EXTERNAL DIMENSIONS & TERMINAL ASSIGNMENTS unit: mm (inch)

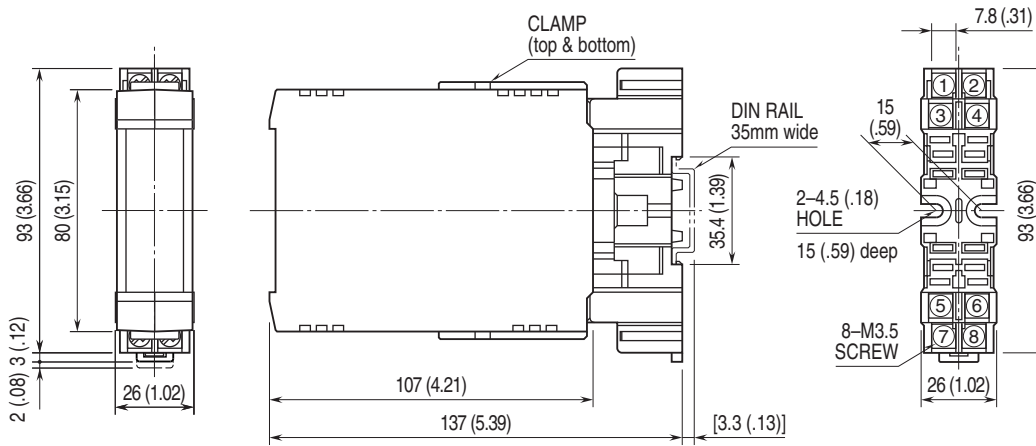

•When mounting, no extra space is needed between units.

SCHEMATIC CIRCUITRY & CONNECTION DIAGRAM

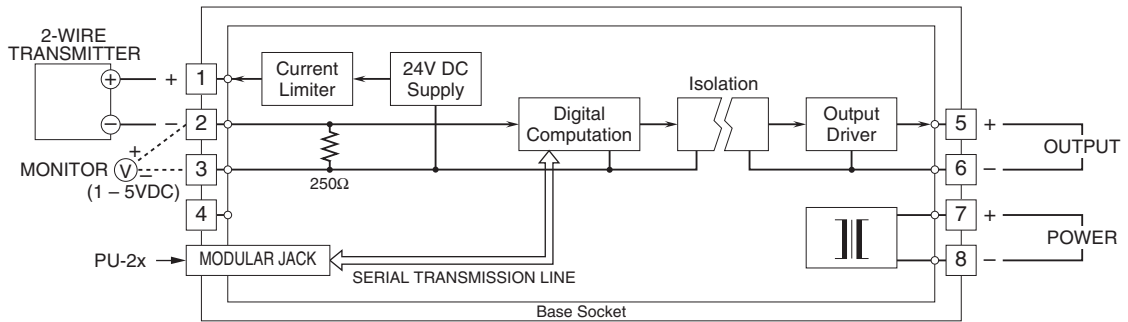

■ When Used as Linearizer

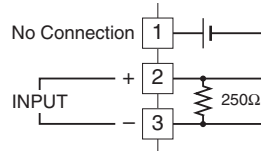

Specifications are subject to change without notice.