

Space-saving Plug-in Signal Conditioners F-UNIT

SIGNAL TRANSMITTER

(high speed response; isolated)

Functions & Features

- Converting a DC input into a standard process signal
- Isolation between input and output
- 180-microsecond response
- High-density mounting

Typical Applications

- Isolation for a vibration analyzing system

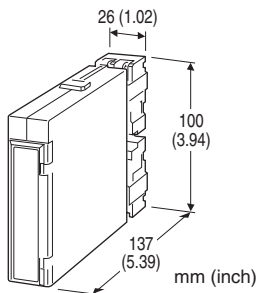

MODEL: FVF-[1][2]-[3]

ORDERING INFORMATION

- Code number: FVF-[1][2]-[3]
- Specify a code from below for each [1] through [3] (e.g. FVF-6A-K)
- Special input and output ranges (For codes Z & 0)

[1] INPUT

Current

- A: 4 - 20 mA DC (Input resistance 250 Ω)
- B: 2 - 10 mA DC (Input resistance 500 Ω)
- C: 1 - 5 mA DC (Input resistance 1000 Ω)
- D: 0 - 20 mA DC (Input resistance 50 Ω)
- E: 0 - 16 mA DC (Input resistance 62.5 Ω)
- F: 0 - 10 mA DC (Input resistance 100 Ω)
- G: 0 - 1 mA DC (Input resistance 1000 Ω)
- H: 10 - 50 mA DC (Input resistance 100 Ω)
- GW: -1 - +1 mA DC (Input resistance 1000 Ω)
- FW: -10 - +10 mA DC (Input resistance 100 Ω)
- Z: Specify current (See INPUT SPECIFICATIONS)

Voltage

- 3: 0 - 1 V DC (Input resistance 1 MΩ min.)
- 4: 0 - 10 V DC (Input resistance 1 MΩ min.)
- 5: 0 - 5 V DC (Input resistance 1 MΩ min.)
- 6: 1 - 5 V DC (Input resistance 1 MΩ min.)
- 4W: -10 - +10 V DC (Input resistance 1 MΩ min.)

- 5W: -5 - +5 V DC (Input resistance 1 MΩ min.)
- 0: Specify voltage (See INPUT SPECIFICATIONS)

[2] OUTPUT

Current

- A: 4 - 20 mA DC (Load resistance 750 Ω max.)
- B: 2 - 10 mA DC (Load resistance 1500 Ω max.)
- C: 1 - 5 mA DC (Load resistance 3000 Ω max.)
- D: 0 - 20 mA DC (Load resistance 750 Ω max.)
- E: 0 - 16 mA DC (Load resistance 900 Ω max.)
- F: 0 - 10 mA DC (Load resistance 1500 Ω max.)
- G: 0 - 1 mA DC (Load resistance 15 kΩ max.)
- Z: Specify current (See OUTPUT SPECIFICATIONS)

Voltage

- 1: 0 - 10 mV DC (Load resistance 10 kΩ min.)
- 2: 0 - 100 mV DC (Load resistance 100 kΩ min.)
- 3: 0 - 1 V DC (Load resistance 1000 Ω min.)
- 4: 0 - 10 V DC (Load resistance 10 kΩ min.)
- 5: 0 - 5 V DC (Load resistance 5000 Ω min.)
- 6: 1 - 5 V DC (Load resistance 5000 Ω min.)
- 4W: -10 - +10 V DC (Load resistance 10 kΩ min.)
- 5W: -5 - +5 V DC (Load resistance 5000 Ω min.)
- 0: Specify voltage (See OUTPUT SPECIFICATIONS)

[3] POWER INPUT

AC Power

- K: 85 - 132 V AC (Operational voltage range 85 - 132 V, 47 - 66 Hz)
- L: 170 - 264 V AC (Operational voltage range 170 - 264 V, 47 - 66 Hz)

DC Power

- R: 24 V DC (Operational voltage range 24 V ±10 %, ripple 10 %p-p max.)
- P: 110 V DC (Operational voltage range 85 - 150 V, ripple 10 %p-p max.)

GENERAL SPECIFICATIONS

- Construction:** Plug-in
- Connection:** M3.5 screw terminals (torque 0.8 N·m)
- Screw terminal:** Nickel-plated steel
- Housing material:** Flame-resistant resin (black)
- Isolation:** Input to output to power
- Overrange output:** Approx. -10 to +120 % at 1 - 5 V
- Zero adjustment:** -5 to +5 % (front)
- Span adjustment:** 95 to 105 % (front)

INPUT SPECIFICATIONS

- **DC Current:** Shunt resistor attached to the input terminals (0.5 W) Specify input resistance value for code Z.



■ **DC Voltage:** -300 - +300 V DC

Minimum span: 1 V

Offset: Max. 1.5 times span

Input resistance: $\geq 1 \text{ M}\Omega$

OUTPUT SPECIFICATIONS

■ **DC Current:** 0 - 20 mA DC

Minimum span: 1 mA

Offset: Max. 1.5 times span

Load resistance: Output drive 15 V max.

■ **DC Voltage:** -10 - +12 V DC

Minimum span: 5 mV

Offset: Max. 1.5 times span

Load resistance: Output drive 1 mA max.; at $\geq 0.5 \text{ V}$

INSTALLATION

Power input

•**AC:** Approx. 4.5 VA

•**DC:** 24 V approx. 70 mA

110 V approx. 20 mA

Operating temperature: -5 to +55°C (23 to 131°F)

Operating humidity: 30 to 90 %RH (non-condensing)

Mounting: Surface or DIN rail; Standard Rack Mounting

Frame BX-16H available

Weight: 180 g (0.40 lbs)

PERFORMANCE in percentage of span

Accuracy: $\pm 0.1 \%$

Temp. coefficient: $\pm 0.015 \%/^{\circ}\text{C}$ ($\pm 0.008 \%/^{\circ}\text{F}$)

Response time: Approx. 180 μsec . (0 - 90 %)

Line voltage effect: $\pm 0.1 \%$ over voltage range

Insulation resistance: $\geq 100 \text{ M}\Omega$ with 500 V DC

Dielectric strength

Power input code R:

1000 V AC @ 1 minute (input to output)

2000 V AC @ 1 minute (input or output or power to ground)

500 V AC @ 1 minute (I/O to power)

Power input code K, L, P:

1000 V AC @ 1 minute (input to output)

2000 V AC @ 1 minute (input or output or power to ground)

1500 V AC @ 1 minute (I/O to power)



DIMENSIONS unit: mm (inch)

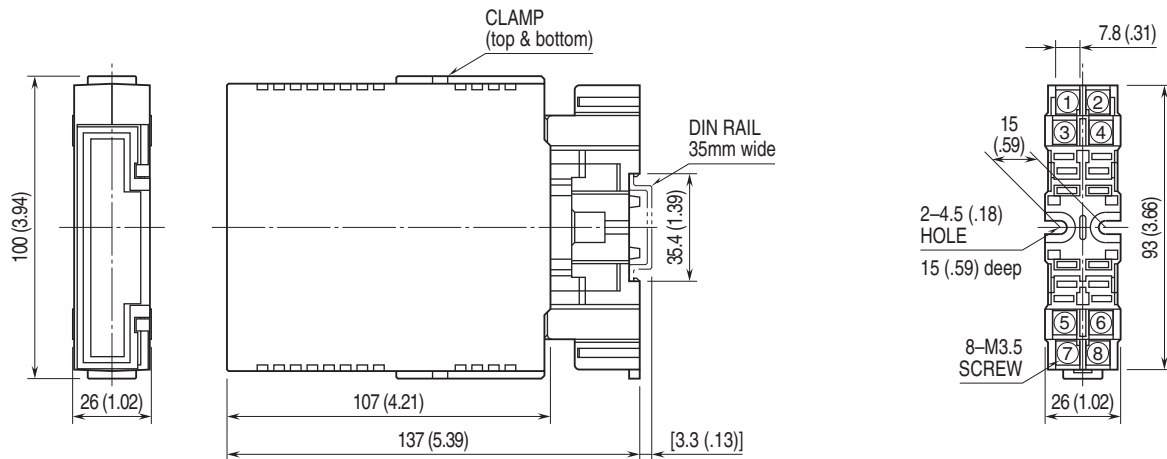

•When mounting, no extra space is needed between units.

TERMINAL ASSIGNMENTS unit: mm (inch)

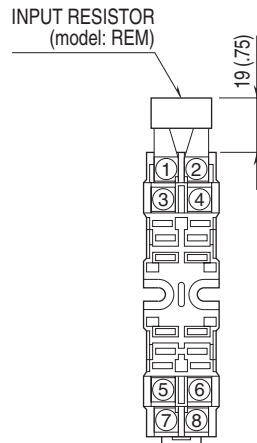

Input shunt resistor attached for current input.

SCHEMATIC CIRCUITRY & CONNECTION DIAGRAM

The FVF, due to its fast-response design, does not eliminate noises included in the input signal. Use shielded twisted-pair cable for preventing them.

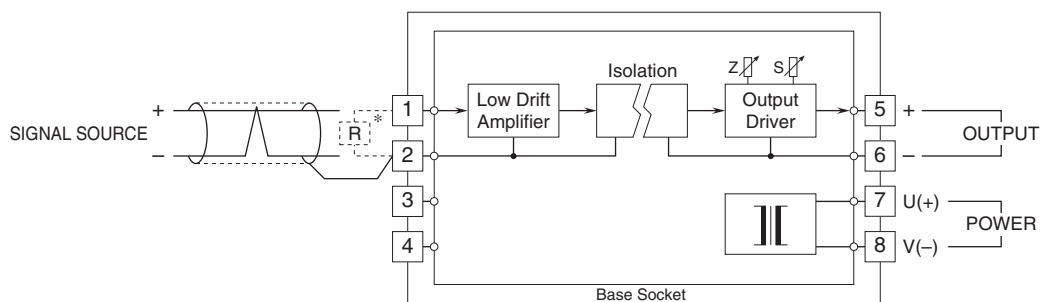

*Input shunt resistor attached for current input.



Specifications are subject to change without notice.

