

Space-saving Plug-in Signal Conditioners F-UNIT

THERMOCOUPLE TRANSMITTER

(field-programmable)

Functions & Features

- Accepting direct input from a thermocouple and providing a standard process signal
- Micro-processor based
- Field-programmable T/C type and temperature range
- Linearization
- Burnout protection
- High accuracy cold junction compensation
- Loop testing via hand-held programmer PU-2x
- High-density mounting

Typical Applications

- Ideal for quick spare part
- High-accuracy cold junction compensation benefits narrow span measurements
- 0.1 μ A burnout sensing enables long distance transmission with minimum offset drifts
- Electric furnace (isolation)
- No burnout type can connect to a single T/C in parallel with recorder

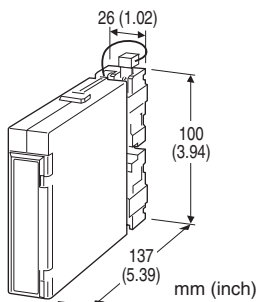

MODEL: FJT-[1][2]-[3][4]

ORDERING INFORMATION

- Code number: FJT-[1][2]-[3][4]
- Specify a code from below for each [1] through [4] (e.g. FJT-2A-R/BL)
- Temperature range (e.g. 0 - 800°C)
- Default setting will be used if not otherwise specified.
K thermocouple setting will be used if the input code is not specified.

[1] INPUT THERMOCOUPLE

- 1: (PR) (Usable Range 0 to 1760°C, 32 to 3200°F)
- 2: K (CA) (Usable range -270 to +1370°C, -454 to +2498°F)
- 3: E (CRC) (Usable range -270 to +1000°C, -454 to +1832°F)

- 4: J (IC) (Usable range -210 to +1200°C, -346 to +2192°F)
- 5: T (CC) (Usable range -270 to +400°C, -454 to +752°F)
- 6: B (RH) (Usable range 0 to 1820°C, 32 to 3308°F)
- 7: R (Usable range -50 to +1760°C, -58 to +3200°F)
- 8: S (Usable range -50 to +1760°C, -58 to +3200°F)
- 9: WRe 5-26 (Usable range 0 to 2320°C, 32 to 4200°F)
- N: N (Usable range -270 to +1300°C, -454 to +2372°F)
- 0: Specify

[2] OUTPUT

Current

A: 4 - 20 mA DC (Load resistance 600 Ω max.)

Voltage

6: 1 - 5 V DC (Load resistance 500 Ω min.)

[3] POWER INPUT

AC Power

K: 85 - 132 V AC

(Operational voltage range 85 - 132 V, 47 - 66 Hz)

L: 170 - 264 V AC

(Operational voltage range 170 - 264 V, 47 - 66 Hz)

DC Power

R: 24 V DC

(Operational voltage range 24 V \pm 10 %, ripple 10 %p-p max.)

P: 110 V DC

(Operational voltage range 85 - 150 V, ripple 10 %p-p max.)

[4] OPTIONS

Burnout

blank: Upscale burnout

/BL: Downscale burnout

/BN: No burnout

RELATED PRODUCTS

- JX configurator connection kit (model: JXCON)
- Programming Unit (model: PU-2x)

GENERAL SPECIFICATIONS

Construction: Plug-in

Connection: M3.5 screw terminals (torque 0.8 N·m)

Screw terminal: Nickel-plated steel

Housing material: Flame-resistant resin (black)

Isolation: Input to output to power

Overrange output: Approx. -10 to +120 % at 1 - 5 V

Linearization: Standard

Cold junction compensation: CJC sensor attached to the input terminals

Adjustments: Programming Unit (model: PU-2x);

(Refer to the users manual of JXCON for the adjustments configurable with JXCON.)



- T/C type
- temp. range
- zero and span
- simulating output
- Others

INPUT SPECIFICATIONS

Minimum span: 3 mV

Offset: Max. 3 times span

Input resistance: 20 kΩ min.

Burnout sensing: 0.1 μA

Minimum span in °C and °F

(PR): 370°C, 670°F

K (CA): 75°C, 140°F

E (CRC): 50°C, 90°F

J (IC): 60°C, 110°F

T (CC): 75°C, 140°F

B (RH): 780°C, 1410°F

R: 360°C, 650°F

S: 380°C, 690°F

WRe5-26: 200°C, 360°F

N: 110°C, 200°F

Remark: The described accuracy may be partially not satisfied when the temperature ranges below 0°C. Consult factory.

If not specified, the input range is shown below.

(PR): 0 to 1600°C

K (CA): 0 to 1000°C

E (CRC): 0 to 500°C

J (IC): 0 to 500°C

T (CC): 0 to 300°C

B (RH): 0 to 1800°C

R: 0 to 1600°C

S: 0 to 1600°C

WRe5-26: 0 to 2000°C

N: 0 to 1000°C

INSTALLATION

Power input

•AC: Approx. 4.5 VA

•DC: 24 V approx. 70 mA

110 V approx. 20 mA

Operating temperature: -5 to +55°C (23 to 131°F)

Operating humidity: 30 to 90 %RH (non-condensing)

Mounting: Surface or DIN rail; Standard Rack Mounting

Frame BX-16H available

Weight: 220 g (0.49 lbs)

PERFORMANCE in percentage of span

Accuracy: ±0.1 %

Linearization accuracy: ±0.05 %

Cold junction compensation error: ±0.5°C or ±0.9°F
(at 20°C ±10°C or 68°F ±18°F)

Temp. coefficient: ±0.015 %/°C (±0.008 %/°F)

Response time: ≤ 0.8 sec. (0 - 90 %)

Burnout response: ≤ 10 sec.

Line voltage effect: ±0.1 % over voltage range

Insulation resistance: ≥ 100 MΩ with 500 V DC

Dielectric strength

Power input code R:

1000 V AC @ 1 minute (input to output)

2000 V AC @ 1 minute (input or output or power to ground)

500 V AC @ 1 minute (I/O to power)

Power input code K, L, P:

1000 V AC @ 1 minute (input to output)

2000 V AC @ 1 minute (input or output or power to ground)

1500 V AC @ 1 minute (I/O to power)



DIMENSIONS unit: mm (inch)

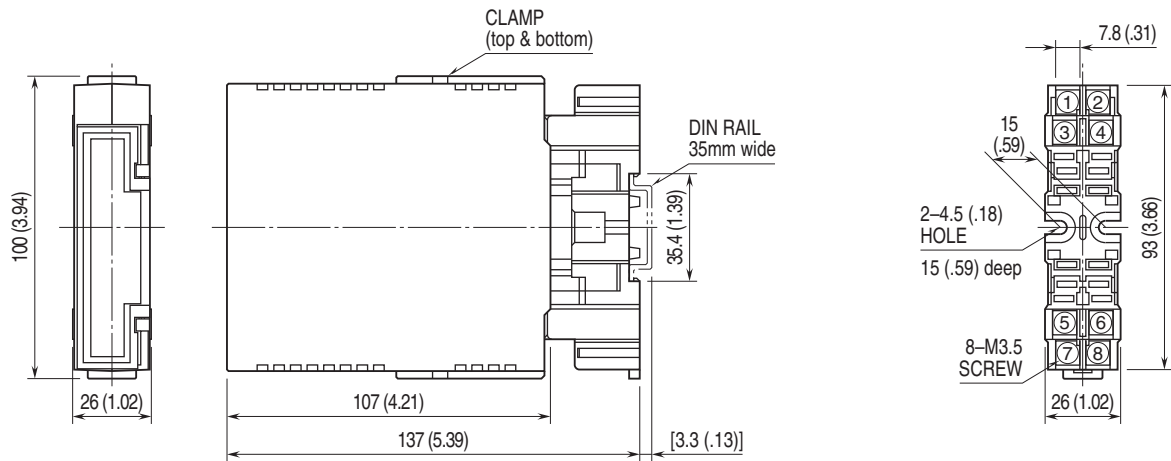

•When mounting, no extra space is needed between units.

TERMINAL ASSIGNMENTS unit: mm (inch)

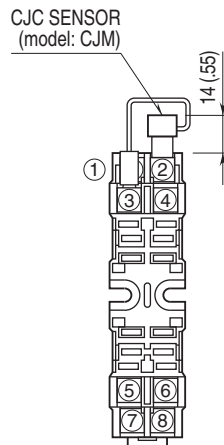

SCHEMATIC CIRCUITRY & CONNECTION DIAGRAM

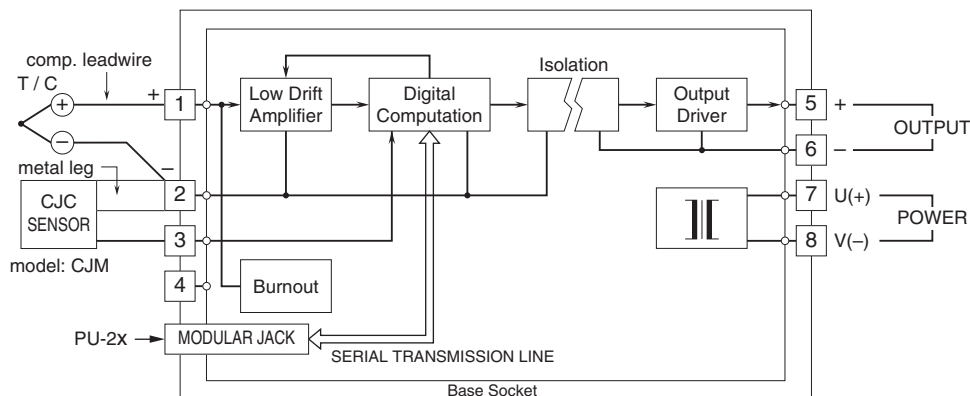

Specifications are subject to change without notice.