

Space-saving Plug-in Signal Conditioners F-UNIT

RAMP BUFFER

(non-isolated)

Functions & Features

- Limiting the rate of change of the output once the rate of the input exceeds the preset value
- Rate-of-change adjustable up to 40 seconds

Typical Applications

- Reducing the rate of change caused by a step change or spikes on the input signal
- Protecting equipment that cannot withstand rapidly changing process variables

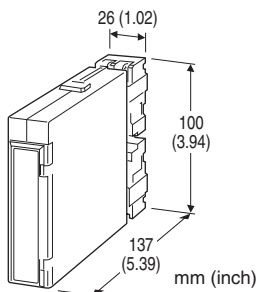

MODEL: FCR-[1][2]-[3]

ORDERING INFORMATION

- Code number: FCR-[1][2]-[3]
- Specify a code from below for each [1] through [3] (e.g. FCR-6A-L)
- Special input and output ranges (For codes Z & 0)

[1] INPUT

Current

- A: 4 - 20 mA DC (Input resistance 250 Ω)
- A1: 4 - 20 mA DC (Input resistance 50 Ω)
- B: 2 - 10 mA DC (Input resistance 500 Ω)
- C: 1 - 5 mA DC (Input resistance 1000 Ω)
- D: 0 - 20 mA DC (Input resistance 50 Ω)
- E: 0 - 16 mA DC (Input resistance 62.5 Ω)
- F: 0 - 10 mA DC (Input resistance 100 Ω)
- G: 0 - 1 mA DC (Input resistance 1000 Ω)
- H: 10 - 50 mA DC (Input resistance 100 Ω)
- J: 0 - 10 μA DC (Input resistance 1000 Ω)
- K: 0 - 100 μA DC (Input resistance 1000 Ω)
- GW: -1 - +1 mA DC (Input resistance 1000 Ω)
- FW: -10 - +10 mA DC (Input resistance 100 Ω)
- Z: Specify current (See INPUT SPECIFICATIONS)

Voltage

- 1: 0 - 10 mV DC (Input resistance 10 kΩ min.)
- 15: 0 - 50 mV DC (Input resistance 10 kΩ min.)
- 16: 0 - 60 mV DC (Input resistance 10 kΩ min.)
- 2: 0 - 100 mV DC (Input resistance 100 kΩ min.)
- 3: 0 - 1 V DC (Input resistance 1 MΩ min.)
- 4: 0 - 10 V DC (Input resistance 1 MΩ min.)
- 5: 0 - 5 V DC (Input resistance 1 MΩ min.)
- 6: 1 - 5 V DC (Input resistance 1 MΩ min.)
- 4W: -10 - +10 V DC (Input resistance 1 MΩ min.)
- 5W: -5 - +5 V DC (Input resistance 1 MΩ min.)
- 0: Specify voltage (See INPUT SPECIFICATIONS)

[2] OUTPUT

Current

- A: 4 - 20 mA DC (Load resistance 750 Ω max.)
- B: 2 - 10 mA DC (Load resistance 1500 Ω max.)
- C: 1 - 5 mA DC (Load resistance 3000 Ω max.)
- D: 0 - 20 mA DC (Load resistance 750 Ω max.)
- E: 0 - 16 mA DC (Load resistance 900 Ω max.)
- F: 0 - 10 mA DC (Load resistance 1500 Ω max.)
- G: 0 - 1 mA DC (Load resistance 15 kΩ max.)
- Z: Specify current (See OUTPUT SPECIFICATIONS)

Voltage

- 1: 0 - 10 mV DC (Load resistance 10 kΩ min.)
- 2: 0 - 100 mV DC (Load resistance 100 kΩ min.)
- 3: 0 - 1 V DC (Load resistance 1000 Ω min.)
- 4: 0 - 10 V DC (Load resistance 10 kΩ min.)
- 5: 0 - 5 V DC (Load resistance 5000 Ω min.)
- 6: 1 - 5 V DC (Load resistance 5000 Ω min.)
- 4W: -10 - +10 V DC (Load resistance 10 kΩ min.)
- 5W: -5 - +5 V DC (Load resistance 5000 Ω min.)
- 0: Specify voltage (See OUTPUT SPECIFICATIONS)

[3] POWER INPUT

AC Power

- K: 85 - 132 V AC
(Operational voltage range 85 - 132 V, 47 - 66 Hz)
- L: 170 - 264 V AC
(Operational voltage range 170 - 264 V, 47 - 66 Hz)

DC Power

- R: 24 V DC
(Operational voltage range 24 V ±10 %, ripple 10 %p-p max.)
- P: 110 V DC
(Operational voltage range 85 - 150 V, ripple 10 %p-p max.)

GENERAL SPECIFICATIONS

- Construction:** Plug-in
- Connection:** M3.5 screw terminals (torque 0.8 N·m)
- Screw terminal:** Nickel-plated steel
- Housing material:** Flame-resistant resin (black)
- Isolation:** Input or output to power



Overrange output: Approx. -10 to +120 % at 1 - 5 V
Rate-of-change adjustment: 260°-turn screwdriver adjustment (front)
Rate-of-change adjustment range: Approx. 0.5 to 40 sec. (0 - 100 %)
Zero adjustment: -5 to +5 % (front)
Span adjustment: 95 to 105 % (front)

500 V AC @ 1 minute (I/O to power)
Power input code K, L, P:
2000 V AC @ 1 minute (input or output or power to ground)
1500 V AC @ 1 minute (I/O to power)

INPUT SPECIFICATIONS

■ **DC Current:**
Shunt resistor attached to the input terminals (0.5 W)
Specify input resistance value for code Z.
■ **DC Voltage:** -300 - +300 V DC
Minimum span: 3 mV
Offset: Max. 1.5 times span
Input resistance
Span 3 - 10 mV : $\geq 10 \text{ k}\Omega$
Span 10 - 100 mV : $\geq 10 \text{ k}\Omega$
Span 0.1 - 1 V : $\geq 100 \text{ k}\Omega$
Span $\geq 1 \text{ V}$: $\geq 1 \text{ M}\Omega$

OUTPUT SPECIFICATIONS

■ **DC Current:** 0 - 20 mA DC
Minimum span: 1 mA
Offset: Max. 1.5 times span
Load resistance: Output drive 15 V max.
■ **DC Voltage:** -10 - +12 V DC
Minimum span: 5 mV
Offset: Max. 1.5 times span
Load resistance: Output drive 1 mA max.; at $\geq 0.5 \text{ V}$

INSTALLATION

Power input
• **AC:** Approx. 4.5 VA
• **DC:** 24 V approx. 70 mA
110 V approx. 20 mA
Operating temperature: -5 to +55°C (23 to 131°F)
Operating humidity: 30 to 90 %RH (non-condensing)
Mounting: Surface or DIN rail; Standard Rack Mounting
Frame BX-16H available
Weight: 200 g (0.44 lbs)

PERFORMANCE in percentage of span

Accuracy: $\pm 0.2 \%$
Temp. coefficient: $\pm 0.015 \%/^{\circ}\text{C}$ ($\pm 0.008 \%/^{\circ}\text{F}$)
Line voltage effect: $\pm 0.1 \%$ over voltage range
Insulation resistance: $\geq 100 \text{ M}\Omega$ with 500 V DC
Dielectric strength
Power input code R:
2000 V AC @ 1 minute (input or output or power to ground)



EXTERNAL VIEW

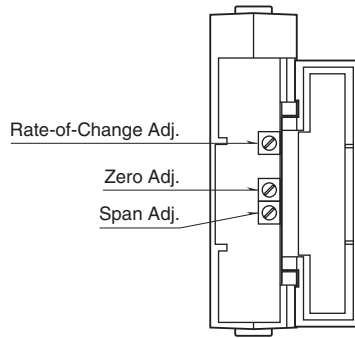

DIMENSIONS unit: mm (inch)

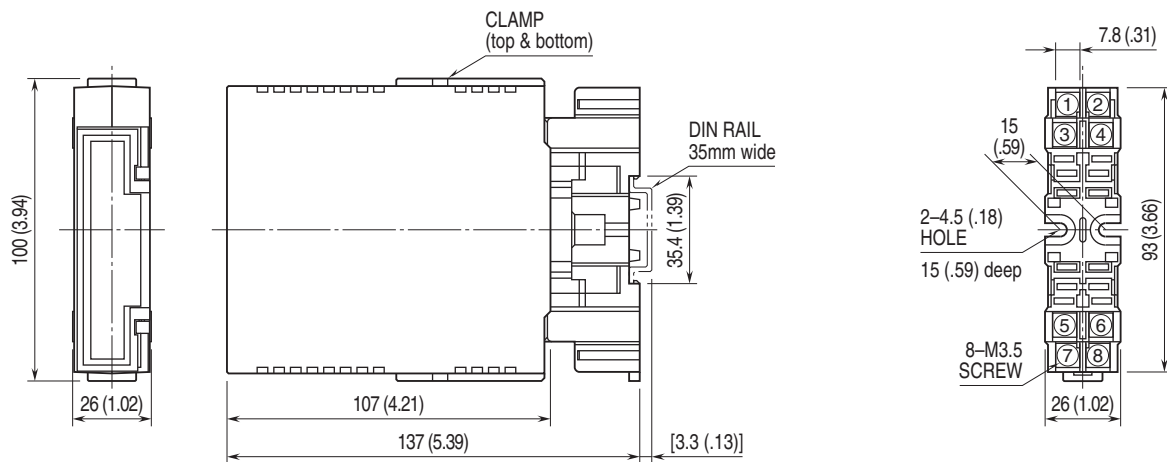

•When mounting, no extra space is needed between units.

TERMINAL ASSIGNMENTS unit: mm (inch)

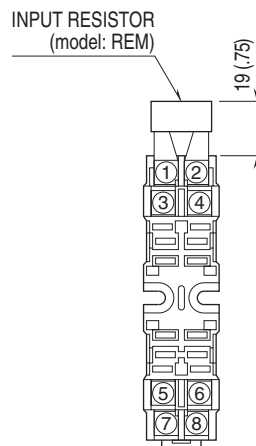

Input shunt resistor attached for current input.

SCHEMATIC CIRCUITRY & CONNECTION DIAGRAM

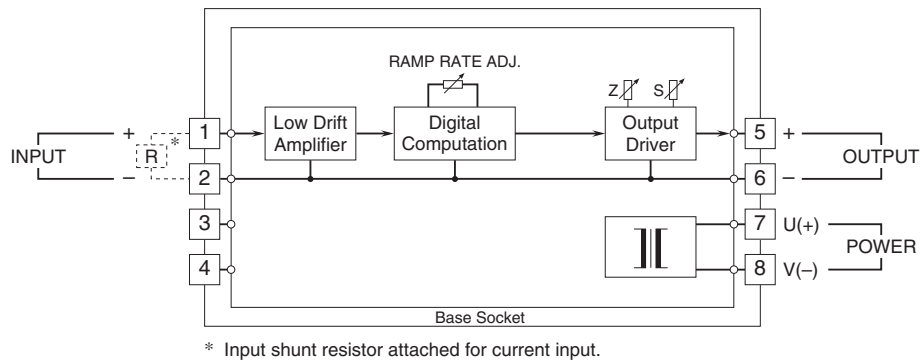

Specifications are subject to change without notice.

