

Space-saving Plug-in Signal Conditioners F-UNIT

DC ALARM

Functions & Features

- Providing relay contact closures at preset DC input levels
- Single or dual (Hi/Lo) trip
- Multi-turn screwdriver setpoint adjustments
- Enclosed relays
- Relays can be powered 110 V DC
- High-density mounting

Typical Applications

- Annunciator
- Various alarm applications

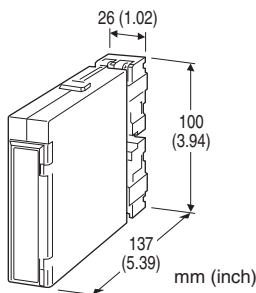

MODEL: FAS-[1][2]-[3]

ORDERING INFORMATION

- Code number: FAS-[1][2]-[3]
- Specify a code from below for each [1] through [3] (e.g. FAS-62-L)
- Special input range (For code 0)
- Use Ordering Information Sheet (No. ESU-1033) to specify output code 0 specifications.

[1] INPUT

Current

- A: 4 - 20 mA DC (Input resistance 250 Ω)
- D: 0 - 20 mA DC (Input resistance 50 Ω)
- G: 0 - 1 mA DC (Input resistance 1000 Ω)
- H: 10 - 50 mA DC (Input resistance 100 Ω)

Voltage

- 3: 0 - 1 V DC (Input resistance 1 M Ω min.)
- 4: 0 - 10 V DC (Input resistance 1 M Ω min.)
- 5: 0 - 5 V DC (Input resistance 1 M Ω min.)
- 6: 1 - 5 V DC (Input resistance 1 M Ω min.)
- 0: Specify voltage (See INPUT SPECIFICATIONS)

[2] OUTPUT

- 1: Single (SPDT); Hi in power failure
- 2: Single (SPDT); Lo in power failure

- 5: Hi/Lo (N.O.); OFF in power failure
- 6: Hi/Lo (N.C.); OFF in power failure
- 0: Specify

[3] POWER INPUT

AC Power

K: 85 - 132 V AC
(Operational voltage range 85 - 132 V, 47 - 66 Hz)

L: 170 - 264 V AC
(Operational voltage range 170 - 264 V, 47 - 66 Hz)

DC Power

R: 24 V DC
(Operational voltage range 24 V \pm 10 %, ripple 10 %p-p max.)

P: 110 V DC
(Operational voltage range 85 - 150 V, ripple 10 %p-p max.)

GENERAL SPECIFICATIONS

- Construction:** Plug-in
- Connection:** M3.5 screw terminals (torque 0.8 N·m)
- Screw terminal:** Nickel-plated steel
- Housing material:** Flame-resistant resin (black)
- Isolation:** Input to output to power
- Setpoint adjustments:** Multi-turn screwdriver adjustments (front); -5 - +105 % independently
- Hysteresis (deadband):** Approx. 1 %
- Front LEDs:** Red light turns on when the coil is energized.
- Power ON timer:** Relays de-energized for approx. 2 seconds after power is turned on.

INPUT SPECIFICATIONS

- **DC Current:**
Shunt resistor attached to the input terminals (0.5 W)
- **DC Voltage:** 0 - 300 V DC
- Minimum span:** 1 V
- Offset:** Max. 1.5 times span
- Input resistance:** \geq 1 M Ω

OUTPUT SPECIFICATIONS

- **Relay Contact:** 100 V AC @ 1 A ($\cos \phi = 1$)
120 V AC @ 1 A ($\cos \phi = 1$)
240 V AC @ 0.5 A ($\cos \phi = 1$)
30 V DC @ 1 A (resistive load)
 - Maximum switching voltage:** 380 V AC or 125 V DC
 - Maximum switching power:** 120 VA or 30 W
 - Minimum load:** 5 V DC @ 10 mA
 - Mechanical life:** 5×10^7 cycles
- For maximum relay life with inductive loads, external protection is recommended.



1500 V AC @ 1 minute (I/O to power)

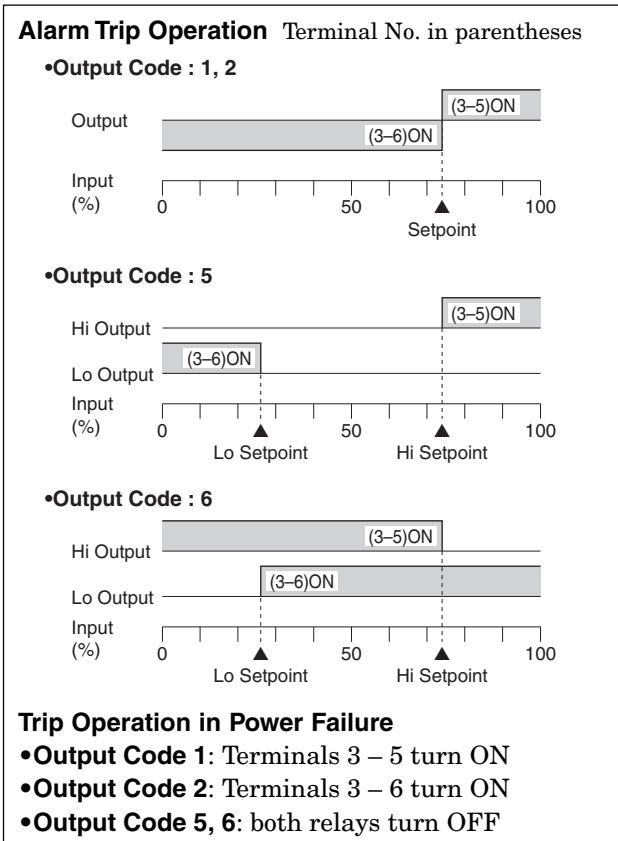

INSTALLATION

Power input

- AC: Approx. 4.5 VA
- DC: 24 V approx. 70 mA
- 110 V approx. 20 mA

Operating temperature: -5 to +55°C (23 to 131°F)

Operating humidity: 30 to 90 %RH (non-condensing)

Mounting: Surface or DIN rail; Standard Rack Mounting
Frame BX-16H available

Weight: 180 g (0.40 lbs)

PERFORMANCE in percentage of span

Trip point repeatability: ± 0.1 %

Temp. coefficient: ± 0.015 %/°C (± 0.008 %/°F)

Response time: ≤ 0.5 sec. (0 - 100 % at 90 % setpoint)

Line voltage effect: ± 0.1 % over voltage range

Insulation resistance: ≥ 100 M Ω with 500 V DC

Dielectric strength

Power input code R:

- 1000 V AC @ 1 minute (input to output)
- 2000 V AC @ 1 minute (input or output or power to ground)
- 500 V AC @ 1 minute (I/O to power)

Power input code K, L, P:

- 1000 V AC @ 1 minute (input to output)
- 2000 V AC @ 1 minute (input or output or power to ground)



幸託有限公司
XIN TOP CORPORATION

TEL : (02)2598-1199
FAX : (02)2596-2331

E-mail : info@xintop.com
Website : www.xintop.com

EXTERNAL VIEW

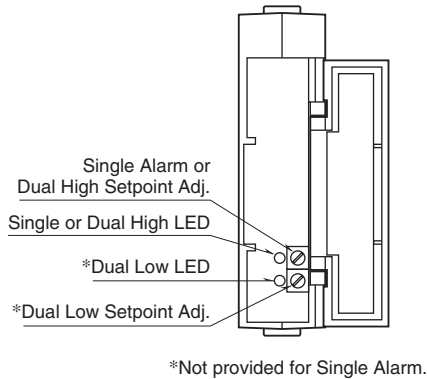

DIMENSIONS unit: mm (inch)

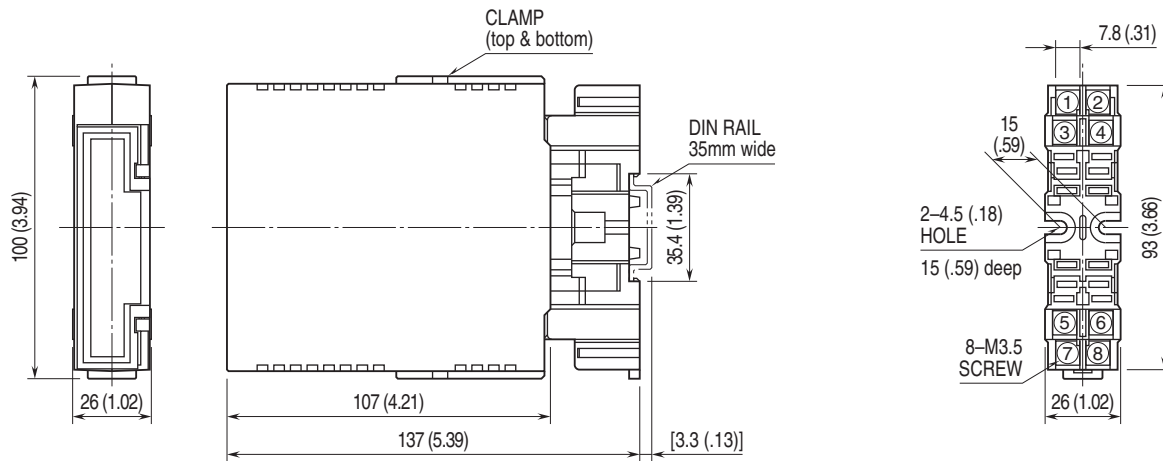

•When mounting, no extra space is needed between units.

TERMINAL ASSIGNMENTS unit: mm (inch)

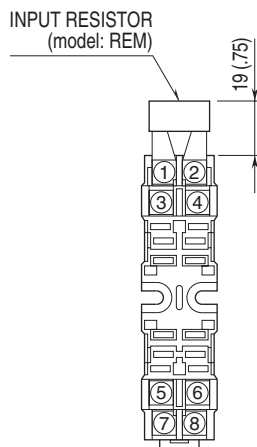

Input shunt resistor attached for current input.



SCHEMATIC CIRCUITRY & CONNECTION DIAGRAM

■ SINGLE ALARM

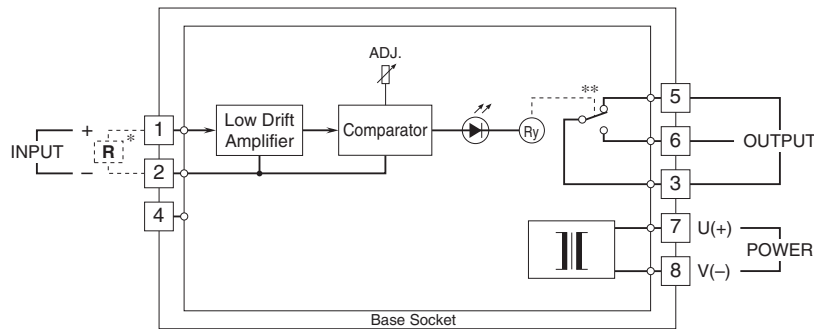

* Input shunt resistor attached for current input.
 **Relay status is determined by output codes.

■ Relay Protection

•AC Powered

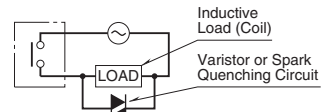

•DC Powered

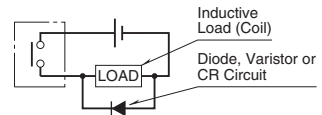

■ DUAL ALARM

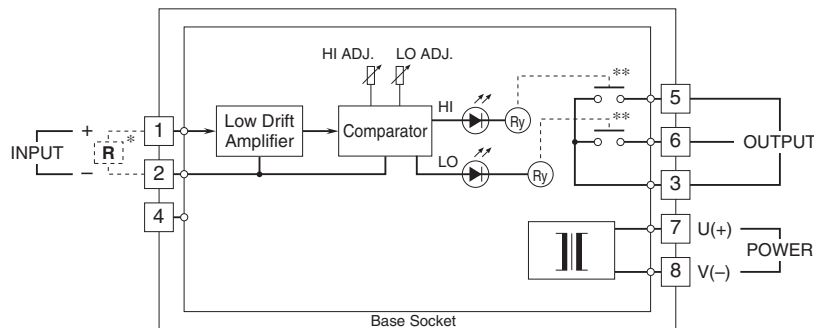

* Input shunt resistor attached for current input.
 **Relay status is determined by output codes.



Specifications are subject to change without notice.