

Plug-in Signal Conditioners M-UNIT

DIFFERENTIAL RTD TRANSMITTER

(non-isolated)

Functions & Features

- Providing a DC output in proportion to the temperature difference between two RTDs
- LCD meter (engineering unit display selectable)
- Simple loop test output (0 % and 100 %)
- High-density mounting

Typical Applications

- Measuring temperature difference between the inlet and outlet of a heat exchanger
- Coolant
- Power plant

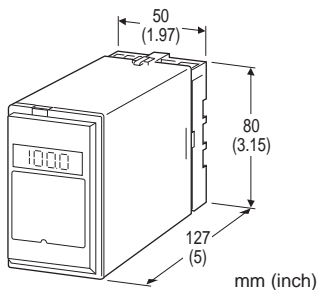

MODEL: DR-[1]-[2][3]

ORDERING INFORMATION

- Code number: DR-[1]-[2][3]
Specify a code from below for each [1] through [3].
(e.g. DR-A-B/E2/Q)
- Special output range (For codes Z & 0)
- Specify the specification for option code /Q
(e.g. /C01/S01)

INPUT (2-wire RTDs, dual input)

JPt100 (JIS'89) or Pt100 (JIS'97, IEC)

Pt100 (JIS '89) is deviated from Pt100

(JIS '97) only within the described accuracy.

[1] OUTPUT

Current

- A: 4 - 20 mA DC (Load resistance 750 Ω max.)
- B: 2 - 10 mA DC (Load resistance 1500 Ω max.)
- C: 1 - 5 mA DC (Load resistance 3000 Ω max.)
- D: 0 - 20 mA DC (Load resistance 750 Ω max.)
- E: 0 - 16 mA DC (Load resistance 900 Ω max.)
- F: 0 - 10 mA DC (Load resistance 1500 Ω max.)

G: 0 - 1 mA DC (Load resistance 15 kΩ max.)

Z: Specify current (See OUTPUT SPECIFICATIONS)

Voltage

- 1: 0 - 10 mV DC (Load resistance 10 kΩ min.)
- 2: 0 - 100 mV DC (Load resistance 100 kΩ min.)
- 3: 0 - 1 V DC (Load resistance 100 Ω min.)
- 4: 0 - 10 V DC (Load resistance 1000 Ω min.)
- 5: 0 - 5 V DC (Load resistance 500 Ω min.)
- 6: 1 - 5 V DC (Load resistance 500 Ω min.)
- 0: Specify voltage (See OUTPUT SPECIFICATIONS)

[2] POWER INPUT

AC Power

- B: 100 V AC
- C: 110 V AC
- D: 115 V AC
- F: 120 V AC
- G: 200 V AC
- H: 220 V AC
- J: 240 V AC

DC Power

- S: 12 V DC
- R: 24 V DC
- V: 48 V DC
- P: 110 V DC (Not selectable with Option /E2)

[3] OPTIONS (multiple selections)

Input Signal Indicator

blank: Without

/E: With (0.0 - 100.0 % display)

/E2: With (in engineering unit with backlight and the simple loop test output)

Other Options

blank: none

/Q: Option other than the above (specify the specification)

SPECIFICATIONS OF OPTION: Q (multiple selections)

COATING (For the detail, refer to M-System's web site.)

/C01: Silicone coating

/C02: Polyurethane coating

/C03: Rubber coating

TERMINAL SCREW MATERIAL

/S01: Stainless steel

GENERAL SPECIFICATIONS

Construction: Plug-in

Connection: M3.5 screw terminals

Screw terminal: Chromated steel (standard) or stainless steel

Housing material: Flame-resistant resin (black)



Isolation: Input or output to power
Overrange output: Approx. -10 to +120 % at 1 - 5 V
Zero adjustment: -5 to +5 % (front)
Span adjustment: 95 to 105 % (front)
Display scaling: -10000 - +10000; ex-factory set to 0.00 - 100.00 (%)
Engineering unit: %, μ V, mV, V, mA, A, °C, °F, Ω , DEG K, mHz, Hz, kHz, VAC, AAC, mg, g, kg, t, rpm or rps selectable
Simple loop test output: 0 % and 100 % signal simulated by selecting the front switch positions.

Temp. coefficient: ± 0.015 %/°C (± 0.008 %/°F)
Response time: ≤ 0.5 sec. (0 - 90 %)
Line voltage effect: ± 0.1 % over voltage range
Insulation resistance: ≥ 100 M Ω with 500 V DC
Dielectric strength: 2000 V AC @1 minute (input or output to power to ground)

INPUT SPECIFICATIONS

Input: 2-wire RTDs (two)
Maximum leadwire resistance: Difference 0.5 Ω maximum between the transmitter and each RTD; each leadwire resistance 10 Ω or less
Sensing current: 2 mA
Difference range: 0 - 20°C or 0 - 36°F (fixed)
Temperature range: 0 - 50°C or 32 - 122°F (fixed)

OUTPUT SPECIFICATIONS

■ **DC Current:** 0 - 20 mA DC
Minimum span: 1 mA
Offset: Max. 1.5 times span
Load resistance: Output drive 15 V max.
■ **DC Voltage:** -10 - +12 V DC
Minimum span: 5 mV
Offset: Max. 1.5 times span
Load resistance: Output drive 10 mA max.; 5 mA for negative voltage output; at ≥ 0.5 V

INSTALLATION

Power input
• **AC:** Operational voltage range: rating ± 10 %, 50/60 ± 2 Hz, approx. 2 VA
(approx. 3 VA with Option /E2)
• **DC:** Operational voltage range: rating ± 10 %, or 85 - 150 V for 110 V rating (ripple 10 % p-p max.) approx. 2 W (80 mA at 24 V; approx. 3 W with Option /E2)
Operating temperature: -5 to +60°C (23 to 140°F)
Operating humidity: 30 to 90 %RH (non-condensing)
Mounting: Surface or DIN rail
Weight: 350 g (0.77 lb)

PERFORMANCE in percentage of span

Accuracy: ± 0.2 % (Temperature within 15 - 35°C or 59 - 95°F)
Display accuracy: $\pm (0.2$ % of FS + 1 digit)
(Temperature within 15 - 35°C or 59 - 95°F)
Simple loop test output setting accuracy: ± 0.5 %



EXTERNAL VIEW

OPTION /E

OPTION /E2

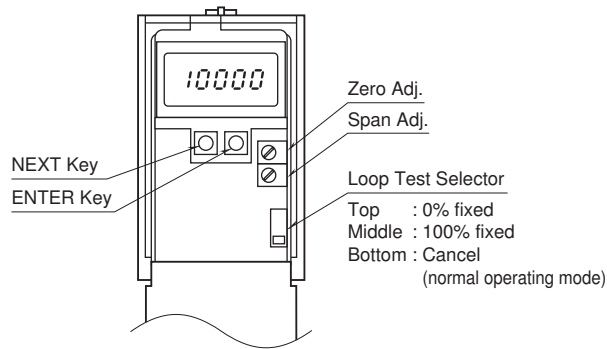
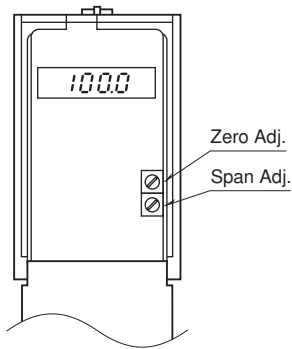

EXTERNAL DIMENSIONS & TERMINAL ASSIGNMENTS unit: mm (inch)

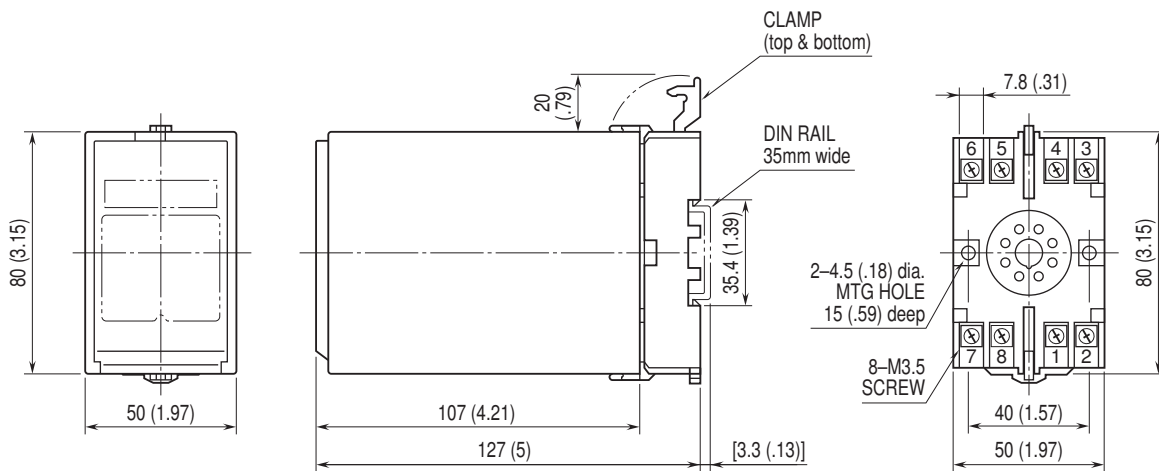

• When mounting, no extra space is needed between units.

SCHEMATIC CIRCUITRY & CONNECTION DIAGRAM

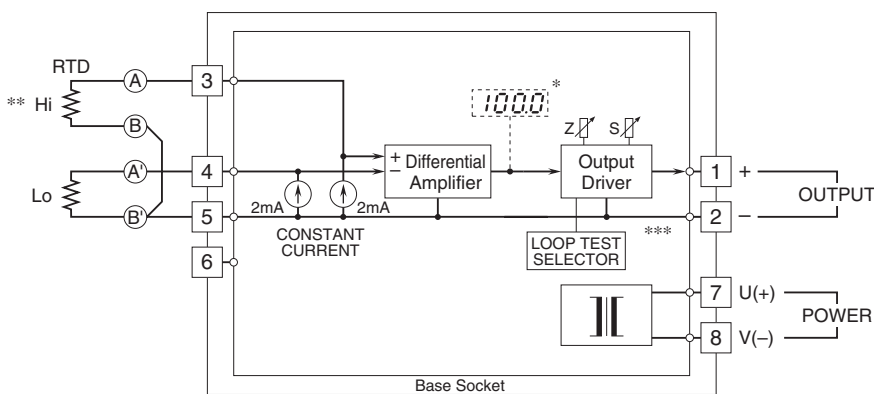

* Option /E, E2

** Be sure to connect the high temp. RTD to the terminal No. 3 for proper operation.

*** Option /E2



Specifications are subject to change without notice.