

## Plug-in Signal Conditioners M-UNIT

### D/A CONVERTER

(16-bit resolution)

#### Functions & Features

- Converts parallel digital signal into a DC output
- BCD, binary, offset binary, two's complement, reflected binary inputs
- Positive or negative logic selectable
- Display can be scaled in convenient engineering unit
- Scalable DC output range
- Parity check

#### Typical Applications

- Interface of analog signal for computers and PLC

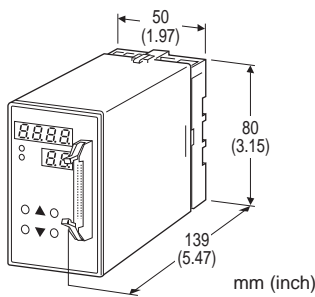

## MODEL: DA3-[1][2]-[3][4]

### ORDERING INFORMATION

- Code number: DA3-[1][2]-[3][4]  
Specify a code from below for each [1] through [4].  
(e.g. DA3-V11-M2/A/Q)
- Specify the specification for option code /Q  
(e.g. /C01/S01)

### [1] OUTPUT

#### Current

**Z1:** Range 0 - 20 mA DC (Load resistance 600Ω max.)

#### Voltage

**V1:** Range -1 - +1 V DC (Load resistance 1000Ω min.)

**V2:** Range -10 - +10 V DC (Load resistance 10kΩ min.)

### [2] RESPONSE TIME

**1:** 400 msec.

**2:** 10 msec.

### [3] POWER INPUT

#### AC Power

**M2:** 100 - 240 V AC (Operational voltage range 85 - 264 V, 47 - 66 Hz)

#### DC Power

**R3:** 12 - 24 V DC

(Operational voltage range 10.8 - 26.4 V, ripple 10 %p-p max.)

**P:** 110 V DC

(Operational voltage range 85 - 150 V, ripple 10 %p-p max.)

### [4] OPTIONS (multiple selections)

#### Input

**Blank:** TTL level

**/A:** 24 V DC

#### Other Options

**blank:** none

**/Q:** Option other than the above (specify the specification)

### SPECIFICATIONS OF OPTION: Q (multiple selections)

#### COATING (For the detail, refer to M-System's web site.)

**/C01:** Silicone coating

**/C02:** Polyurethane coating

**/C03:** Rubber coating

#### TERMINAL SCREW MATERIAL

**/S01:** Stainless steel

### RELATED PRODUCTS

- Connector terminal block (model: CNT)
- Special cable (model: MCN26)

### GENERAL SPECIFICATIONS

**Construction:** Plug-in

#### Connection

**Input:** 26-pin connector(OMRON XG4A-2634)

**Paired connector:** OMRON XG4M-2630-T, XG5M-263x-N

**Cover:** OMRON XG5S-2612

**Output, power:** M3.5 screw terminals

**Screw terminal:** Chromated steel (standard) or stainless steel

**Housing material:** Flame-resistant resin (black)

**Isolation:** Input to output to power

**Overrange output:** Approx. -15 to +115 %

#### ■ DISPLAY

**LED:** 7 mm (.28") 7 segment, red

**Number of display digits:** 4 digits for DATA display; 2 digits for ITEM display

**PV indication:** Input signal in engineering unit

**Overrange indication:** LEDs blinking

**Power saving mode:** Displays turn off if the keys are untouched for a preset time period

**PL1 (POL) LED:** Red light turns on at negative polarity.

**PL2 (LOAD) LED:** Red light turns on at LOAD.

**Setting:** Via the front key pad

- Display range scaling



- Available number of bits
- Data input logic
- POL input
- LOAD input
- Parity check

For detailed information, refer to the instruction manual.

## INPUT SPECIFICATIONS

■ **Input Code:** Code, logic and scaling are user-selectable.

- BCD with polarity
- Binary with polarity
- Offset binary
- Two's complement
- Reflected binary

■ **Input Specifications**

● **TTL Level:** TTL level (5 V-CMOS level) or open collector (sink type), dry contact (saturation voltage  $\leq 1$  V, sink current 1 mA)

**Saturation voltage:**  $\leq 1$  V

**Sink current:** 1 mA

**Common:** Negative

● **24 V DC:** Open collector (source type)

**Rated voltage:** 24 V DC  $\pm 10\%$ , ripple 5 %p-p max.

**ON voltage/current:**  $\geq 18$  V / 2.5 mA DC

**OFF voltage/current:**  $\leq 3$  V / 0.4 mA DC

**Input current:**  $\leq 3.5$  mA @24 V DC

**Input resistance:** Approx. 7.5 k $\Omega$

**Common:** Negative

## OUTPUT SPECIFICATIONS

■ **DC Current:** 0 - 20 mA DC

**Operational range:** 0 - 24.0 mA DC

**Minimum increment:** 0.1 mA

**Default setting:** 4 - 20 mA DC

■ **DC Voltage**

**Code V1:** -1.00 - +1.00 V DC

**Operational range:** -1.15 - +1.15 V DC

**Minimum increment:** 10 mV

**Code V2:** -10.0 - +10.0 V DC

**Operational range:** -11.5 - +11.5 V DC

**Minimum increment:** 100 mV

**Default setting:**

**Code V1:** -1.00 - +1.00 V DC

**Code V2:** -10.00 - +10.00 V DC

## INSTALLATION

**Power consumption**

• **AC:** Approx. 10 VA

• **DC:** Approx. 4 W (160 mA at 24 V)

**Operating temperature:** -5 to +55°C (23 to 131°F)

**Operating humidity:** 30 to 90 %RH (non-condensing)

**Mounting:** Surface or DIN rail

**Weight:** 300 g (0.66 lb)

## PERFORMANCE in percentage of span

**Accuracy:**  $\pm 0.1$  %

**Temp. coefficient:**  $\pm 0.015$  %/°C ( $\pm 0.008$  %/°F)

**Resolution:** 16 bits

**Response time:**  $\leq 400$  msec. or  $\leq 10$  msec. (0 - 90 %)

as specified by model suffix code, with ITEM 16 set to 0.0.

**Line voltage effect:**  $\pm 0.1$  % over voltage range

**Insulation resistance:**  $\geq 100$  M $\Omega$  with 500 V DC

**Dielectric strength:** 2000 V AC @1 minute (input to output to power to ground)

## STANDARDS & APPROVALS

**CE conformity:**

EMC Directive (2004/108/EC)

EMI EN 61000-6-4: 2007

EMS EN 61000-6-2: 2005

Low Voltage Directive (2006/95/EC)

EN 61010-1: 2001

Installation Category II

Pollution Degree 2

Input or output to power: Reinforced insulation (300 V)

Input to output: Basic insulation (300 V)



**EXTERNAL VIEW**

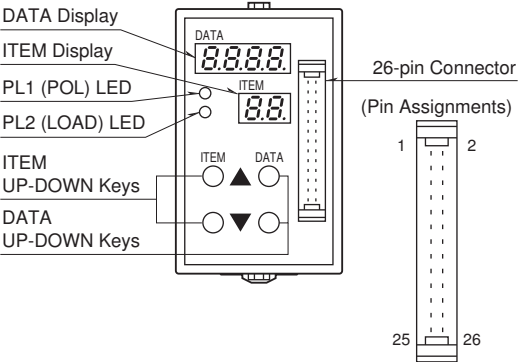

**EXTERNAL DIMENSIONS & TERMINAL ASSIGNMENTS unit: mm (inch)**

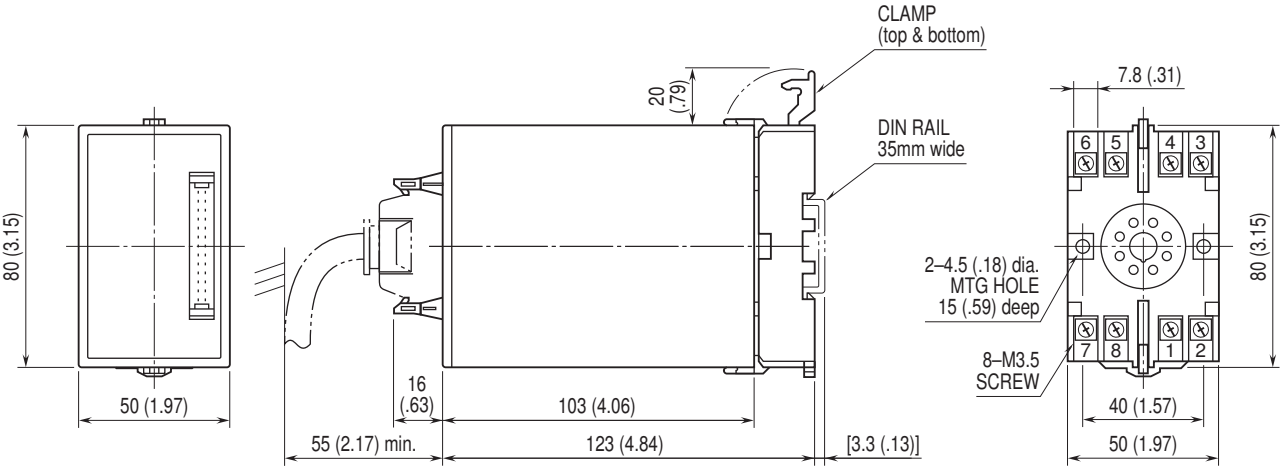

•When mounting, no extra space is needed between units.



## SCHEMATIC CIRCUITRY & CONNECTION DIAGRAM

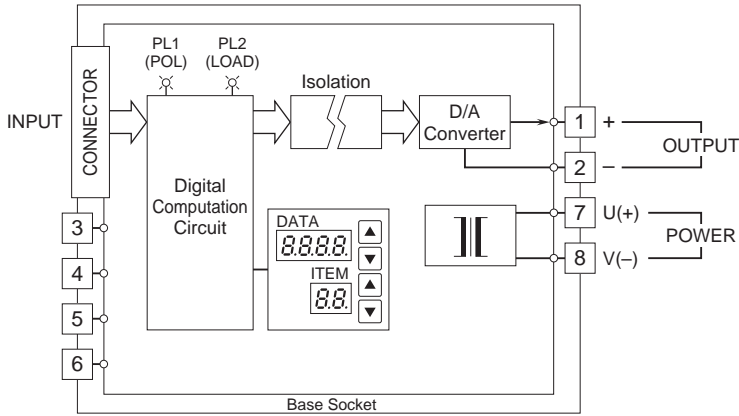

### Input Connection Examples

- Standard type
- TTL level

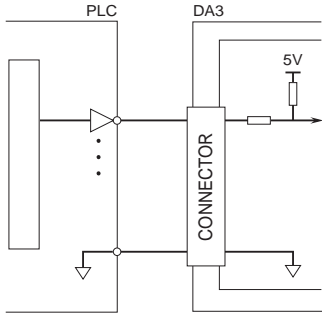

### Open collector, sink type

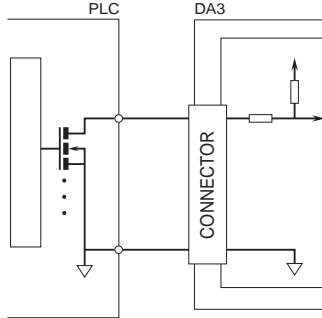

- Option /A
- 24V DC

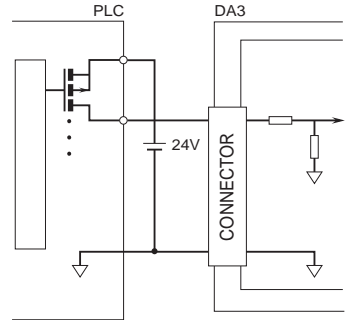

## INPUT CONNECTOR (26-pin)

### BCD INPUT

PIN NO.	ASSIGNMENT	PIN NO.	ASSIGNMENT
1	$1 \times 10^0$	17	COM (-)
2	$2 \times 10^0$	18	COM (-)
3	$4 \times 10^0$	19	No connection
4	$8 \times 10^0$	20	POL
5	$1 \times 10^1$	21	LOAD*1
6	$2 \times 10^1$	22	LOAD*1
7	$4 \times 10^1$	23	P <sup>0</sup> *2
8	$8 \times 10^1$	24	P <sup>1</sup>
9	$1 \times 10^2$	25	P <sup>2</sup>
10	$2 \times 10^2$	26	P <sup>3</sup>
11	$4 \times 10^2$		
12	$8 \times 10^2$		
13	$1 \times 10^3$		
14	$2 \times 10^3$		
15	$4 \times 10^3$		
16	$8 \times 10^3$		

\*1. Pin No. 21 and 22 are internally connected.

\*2. P<sup>0</sup> corresponds to  $n \times 10^0$ , P<sup>1</sup> to  $n \times 10^1$ , P<sup>2</sup> to  $n \times 10^2$ , P<sup>3</sup> to  $n \times 10^3$ . Only P<sup>0</sup> corresponds when the parity for all digits are valid.

Note: With the number of bits set to 14 (or 12, 10, 8) with ITEM 07, Pin No. 1 - 14 (or 1 - 12, 1 - 10, 1 - 8) are valid.

### BINARY TWO'S COMPLEMENT INPUTS

PIN NO.	ASSIGNMENT	PIN NO.	ASSIGNMENT
1	B <sup>0</sup>	17	COM (-)
2	B <sup>1</sup>	18	COM (-)
3	B <sup>2</sup>	19	No connection
4	B <sup>3</sup>	20	POL
5	B <sup>4</sup>	21	LOAD*3
6	B <sup>5</sup>	22	LOAD*3
7	B <sup>6</sup>	23	P <sup>0</sup> *4
8	B <sup>7</sup>	24	P <sup>1</sup>
9	B <sup>8</sup>	25	P <sup>2</sup>
10	B <sup>9</sup>	26	P <sup>3</sup>
11	B <sup>10</sup>		
12	B <sup>11</sup>		
13	B <sup>12</sup>		
14	B <sup>13</sup>		
15	B <sup>14</sup>		
16	B <sup>15</sup>		

\*1. Pin No. 21 and 22 are internally connected.

\*2. P<sup>0</sup> corresponds to B<sup>0</sup> through B<sup>3</sup>, P<sup>1</sup> to B<sup>4</sup> through B<sup>7</sup>, P<sup>2</sup> to B<sup>8</sup> through B<sup>11</sup>, P<sup>3</sup> to B<sup>12</sup> through B<sup>15</sup>.

Only P<sup>0</sup> corresponds when the parity for all digits are valid.

Note: With the number of bits set to 14 (or 12, 10, 8) with ITEM 07, Pin No. 1 - 14 (or 1 - 12, 1 - 10, 1 - 8) are valid.



**TIMING CHART**

• Example: TTL Level Input (factory setting)

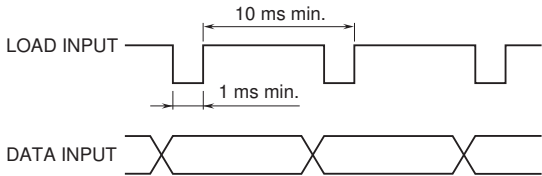

The unit reads data upon detecting a change of LOAD input status.  
DO NOT change LOAD input setting when the data input logic is changed.

**INPUT-OUTPUT RELATION EXAMPLES**

BCD, BINARY (WITH POLARITY)

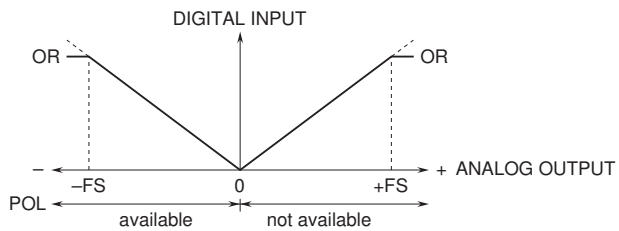
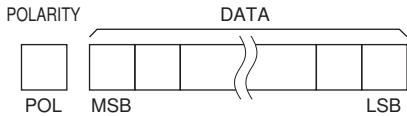

OFFSET BINARY

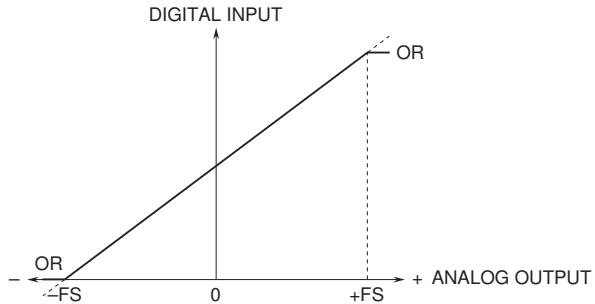
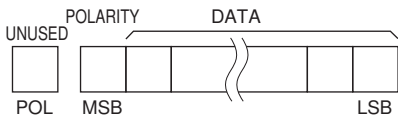

TWO'S COMPLEMENT

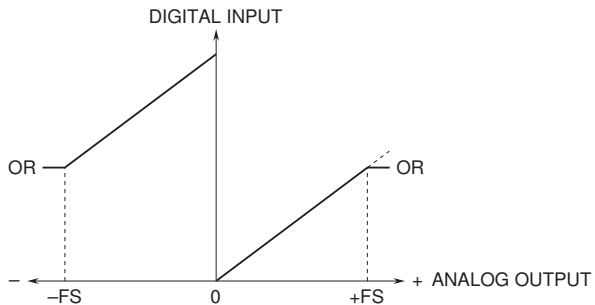
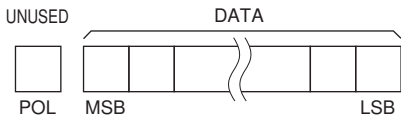

Specifications are subject to change without notice.

